

SFG CONNECTOR

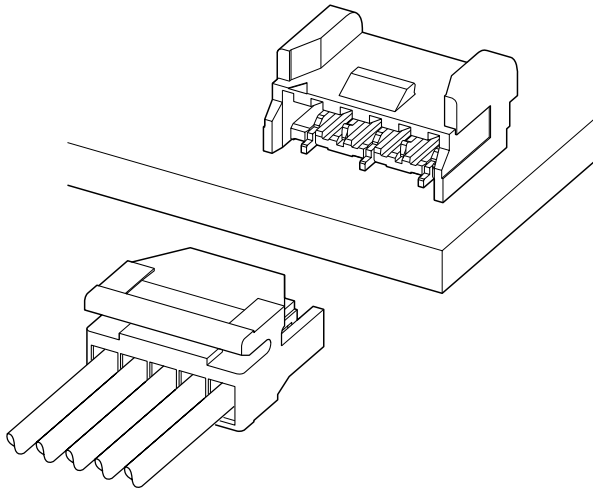

1.1mm pitch/Disconnectable Crimp style connectors



This SFG connector is a wire-to-board connector compatible with small space. It is used for power supply of LED backlight in Liquid Crystal Display Television set.

- Withstand high voltage
- Secure locking structure
- Halogen-free

Specifications

- Current rating: 1.0 A AC, DC (AWG #28)
- Voltage rating: 200 V AC, DC
- Temperature range: -25°C to +85°C
(including temperature rise in applying electrical current)
- Contact resistance: Initial value/ 20 mΩ max.
After environmental tests/ 40 mΩ max.
- Insulation resistance: 100 MΩ min.
- Withstanding voltage: 600 VAC/minute
- Applicable wire: Conductor size/ AWG #30 to #28
Insulation O.D./ 0.72 to 0.9 mm

- * Refer to "General Instruction and Notice when using Terminals and Connectors" at the end of this catalog.
- * Contact JST for details.
- * Compliant with RoHS.

Standards

Recognized E60389

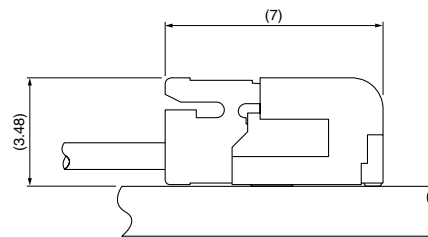
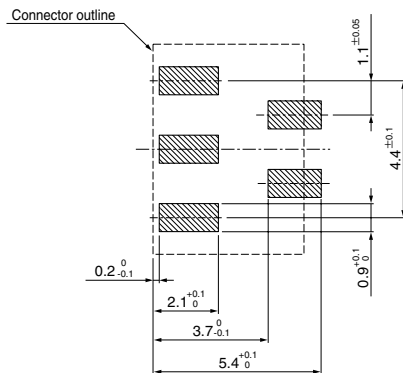

Note: 1. The above figure is the figure viewed from the connector mounting side.

2. Tolerances are non-cumulative: ±0.05 mm for all centers. The dimensions above should serve as a guideline. Contact JST for details.

Contact

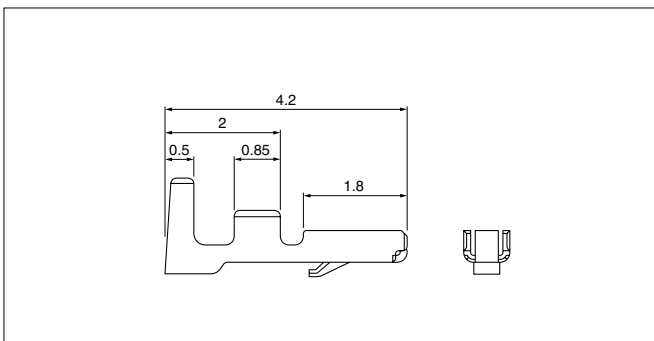

Model No.	Applicable wire		Insulation O.D. (mm)	Q'ty / reel
	mm ²	AWG#		
SSFG-003T-P0.2	0.05~0.08	30~28	0.72~0.9	25,000

Material and Finish

Phosphor bronze, tin-plated (reflow treatment)

RoHS compliance

Contact	Crimping machine	Applicator		
		Crimp applicator	Dies	Crimp applicator with dies
SSFG-003T-P0.2	AP-K2N	MKS-L-10-3	MK/SSFG-003-02	APLMK SSFG003-02
		—	—	—

SFG CONNECTOR

Housing

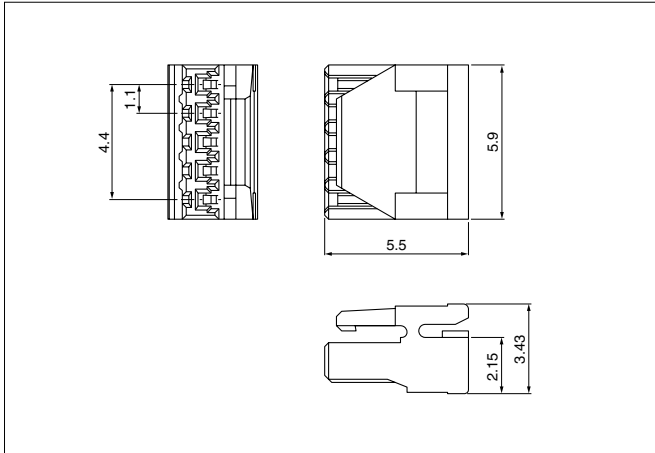

Circuits	Model No.	Q'ty / bag
5	SFGR-05V-S	1,000

Material		
PA 66, UL94V-0, natural (white)		

RoHS compliance

Header

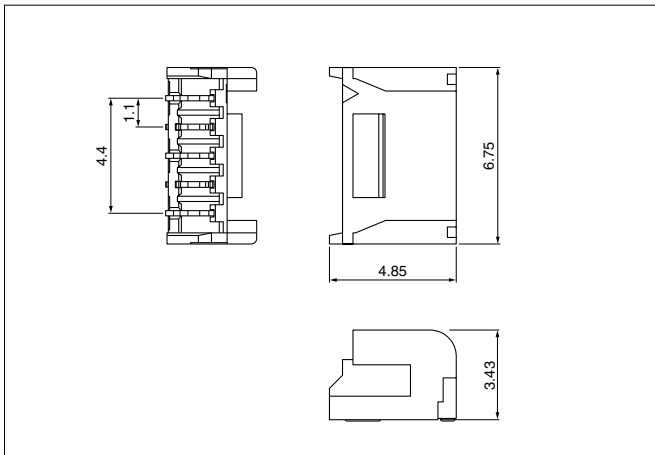

Circuits	Model No.	Q'ty / reel
5	SM05B-SFGH-TF(HF)	3,000

Material and Finish		
---------------------	--	--

Contact A, B: Phosphor bronze, copper-undercoated, tin-plated (reflow treatment)
Base housing: Modified PA 6T, UL94V-0, gray

RoHS compliance

Note: The product listed above is supplied on embossed-tape.