

Jun.1.2019 Copyright 2019 HIROSE ELECTRIC CO., LTD. All Rights Reserved.
 In case of consideration for using Automotive equipment / device which demand high reliability, kindly contact our sales window correspondents.

1 2 3 4 5 6 7 8

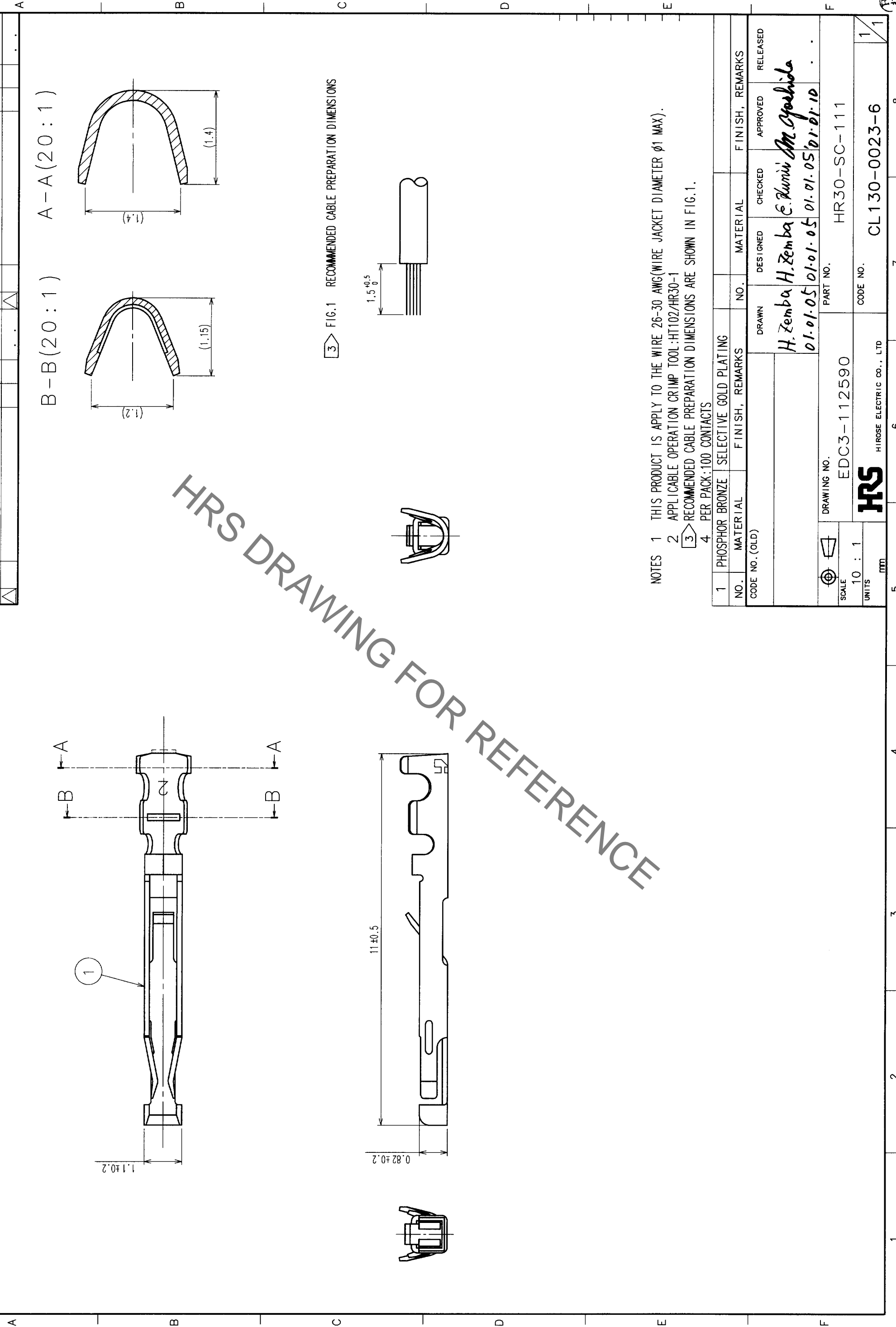

HRS DRAWING FOR REFERENCE

3 FIG.1 RECOMMENDED CABLE PREPARATION DIMENSIONS

- NOTES
- 1 THIS PRODUCT IS APPLY TO THE WIRE 26-30 AWG(WIRE JACKET DIAMETER ϕ 1 MAX).
 - 2 APPLICABLE OPERATION CRIMP TOOL:HT102/HR30-1
 - 3 RECOMMENDED CABLE PREPARATION DIMENSIONS ARE SHOWN IN FIG.1.
 - 4 PER PACK:100 CONTACTS

TO	
R	

NO.	MATERIAL	FINISH, REMARKS	NO.	MATERIAL	FINISH, REMARKS
1	PHOSPHOR BRONZE	SELECTIVE GOLD PLATING			
CODE NO. (OLD)					
DRAWN			DESIGNED	CHECKED	APPROVED
H. Zemba			H. Zemba	E. Kuni	M. Yoshida
01.01.05			01.01.05	01.01.05	01.01.10
PART NO.					
DRAWING NO.			HR30-SC-111		
SCALE			EDC3-112590		
UNITS			CODE NO.		
10 : 1			CL130-0023-6		
mm					

A B C D E F 1 2 3 4 5 6 7 8