

Solderless terminals

# RING TONGUE (R type) vinyl-insulated (straight)

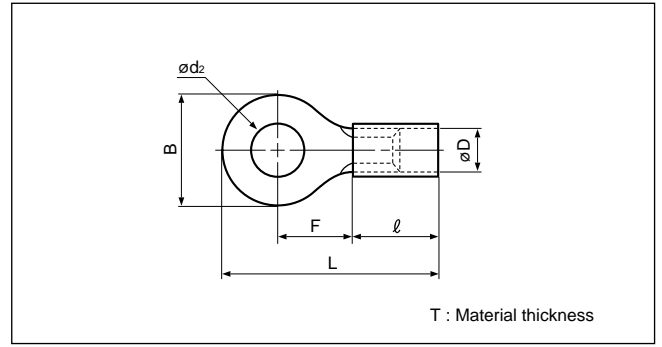

Certificate No.: E42024 LR20812 JQ0608019  
JIS C 2805

Applicable Wire AWG#(mm <sup>2</sup> )	Stud size		Part No.		Standard	Dimensions mm (in.)							Color	Tool No.	Qty/box
	American	Metric	JST	JIS		$\phi d_2$	B	L	F	$\ell$	$\phi D$	T			
26 to 22 (0.2 to 0.5)	1-2	2	V0.5-2			2.2 (.087)	5.2 (.205)	16.4 (.646)	5.8 (.228)	8.0 (.315)	1.9 (.075)	0.5 (.020)	Yellow	YNT-2622 YA-1 YA-2 BCT-0514L	1,000
	3-4	3	V0.5-3			3.2 (.126)	5.2 (.205)	16.4 (.646)	5.8 (.228)						
	5-6	3.5	V0.5-3.7			3.7 (.146)	6.6 (.260)	19.0 (.748)	7.7 (.303)						
	8	4	V0.5-4			4.3 (.169)	6.6 (.260)	19.0 (.748)	7.7 (.303)						
	10	5	V0.5-5			5.3 (.209)	8.0 (.315)	19.0 (.748)	7.0 (.276)						
22 to 16 *(0.25 to 1.65)	1-2	2	V1.25-2			2.2 (.087)	5.5 (.217)	15.7 (.618)	4.0 (.157)	9.0 (.354)	3.2 (.126)	0.8 (.031)	Red	YNT-2216 YA-1 YA-2 YA-4 BCT-0514L	1,000
	3-4	3	V1.25-3	RAA1.25-3		3.2 (.126)	5.5 (.217)	15.7 (.618)	4.0 (.157)						
	3-4	3	V1.25-MS3			3.2 (.126)	5.5 (.217)	17.4 (.685)	5.6 (.220)						
	3-4	3	V1.25-L3			3.2 (.126)	8.0 (.315)	20.0 (.787)	7.0 (.276)						
	5-6	3.5	V1.25-3.7			3.7 (.146)	5.5 (.217)	15.7 (.618)	4.0 (.157)						
	5-6	3.5	V1.25-M3	RAA1.25-3.5		3.7 (.146)	6.6 (.260)	18.6 (.732)	6.3 (.248)						
	8	4	V1.25-M4			4.3 (.169)	6.6 (.260)	18.6 (.732)	6.3 (.248)						
	8	4	V1.25-4	RAA1.25-4		4.3 (.169)	8.0 (.315)	20.0 (.787)	7.0 (.276)						
	10	5	V1.25-5NS			5.3 (.209)	9.0 (.354)	24.6 (.969)	11.1 (.437)						
	10	5	V1.25-5	RAA1.25-5		5.3 (.209)	8.0 (.315)	20.0 (.787)	7.0 (.276)						
	1/4	6	V1.25-6			6.4 (.252)	11.6 (.457)	25.9 (1.020)	11.1 (.437)						
	5/16	8	V1.25-8			8.4 (.331)	11.6 (.457)	25.9 (1.020)	11.1 (.437)						
	3/8	10	V1.25-10			10.5 (.413)	13.6 (.535)	29.7 (1.169)	13.9 (.547)						
16 to 14 (1.04 to 2.63)	1-2	2	V2-S2			2.2 (.087)	6.4 (.252)	16.5 (.650)	4.3 (.169)	9.0 (.354)	3.9 (.154)	0.8 (.031)	Blue	YNT-1614 YA-1 YA-2 YA-4 BCT-0514L	1,000
	3-4	3	V2-MS3			3.2 (.126)	5.5 (.217)	17.4 (.685)	5.6 (.220)						
	3-4	3	V2-S3.3			3.2 (.126)	6.4 (.252)	16.5 (.650)	4.3 (.169)						
	3-4	3	V2-3			3.2 (.126)	8.5 (.335)	21.0 (.827)	7.8 (.307)						
	5-6	3.5	V2-S3			3.7 (.146)	6.4 (.252)	16.5 (.650)	4.3 (.169)						
	5-6	3.5	V2-M3	RAA2-3.5		3.7 (.146)	6.6 (.260)	18.6 (.732)	6.3 (.248)						
	5-6	3.5	V2-P3.5			3.7 (.146)	7.0 (.276)	20.2 (.780)	7.7 (.303)						
	8	4	V2-M4			4.3 (.169)	6.6 (.260)	18.6 (.732)	6.3 (.248)						
	8	4	V2-P4			4.3 (.169)	7.0 (.276)	20.2 (.800)	7.7 (.303)						
	8	4	V2-4	RAA2-4		4.3 (.169)	8.5 (.335)	21.0 (.827)	7.8 (.307)						
	10	5	V2-M5			5.3 (.209)	8.5 (.335)	21.0 (.827)	7.8 (.307)						
	10	5	V2-SNS			5.3 (.209)	9.0 (.354)	24.5 (.965)	11.0 (.433)						
	10	5	V2-5	RAA2-5		5.3 (.209)	9.5 (.374)	21.0 (.827)	7.3 (.287)						
	1/4	6	V2-6	RAA2-6		6.4 (.252)	12.0 (.472)	26.0 (1.024)	11.0 (.433)						
	5/16	8	V2-8	RAA2-8		8.4 (.331)	12.0 (.472)	26.0 (1.024)	11.0 (.433)						
	3/8	10	V2-10			10.5 (.413)	13.6 (.535)	29.7 (1.169)	13.9 (.547)						
	1/2	12	V2-12			13.0 (.512)	19.0 (.748)	35.2 (1.386)	16.7 (.657)						
	1/2	14	V2-14			15.0 (.591)	27.0 (1.063)	43.7 (1.720)	21.2 (.835)						
	5/8	16	V2-16			17.0 (.669)	27.0 (1.063)	43.7 (1.720)	21.2 (.835)						
	3/4	20	V2-20			21.0 (.827)	27.0 (1.063)	43.7 (1.720)	21.2 (.835)						
12 to 10 (2.63 to 6.64)	5-6	3.5	V5.5-S3			3.7 (.146)	7.2 (.283)	23.0 (.906)	5.9 (.232)	13.5 (.531)	5.4 (.213)	1.0 (.039)	Yellow	YNT-1210S YA-4 BCT-0514L	500
	3-4	3	V5.5-3			3.2 (.126)	9.5 (.374)	26.5 (1.043)	8.3 (.327)						
	8	4	V5.5-S4			4.3 (.169)	7.2 (.283)	23.0 (.906)	5.9 (.232)						
	8	4	V5.5-4	RAA5.5-4		4.3 (.169)	9.5 (.374)	26.5 (1.043)	8.3 (.327)						
	10	5	V5.5-5	RAA5.5-5		5.3 (.209)	9.5 (.374)	26.5 (1.043)	8.3 (.327)						
	10	5	V5.5-S5			5.3 (.209)	13.2 (.520)	29.1 (1.146)	9.0 (.354)						
	1/4	6	V5.5-6	RAA5.5-6		6.4 (.252)	12.0 (.472)	32.5 (1.280)	13.0 (.512)						
	1/4	6	V5.5-S6			6.4 (.252)	13.2 (.520)	29.1 (1.146)	9.0 (.354)						
	5/16	8	V5.5-S8			8.4 (.331)	13.2 (.520)	29.1 (1.146)	9.0 (.354)						
	5/16	8	V5.5-8	RAA5.5-8		8.4 (.331)	15.0 (.591)	34.7 (1.366)	13.7 (.539)						
	3/8	10	V5.5-10	RAA5.5-10		10.5 (.413)	15.0 (.591)	34.7 (1.366)	13.7 (.539)						
	1/2	12	V5.5-12			13.0 (.512)	19.2 (.756)	39.1 (1.539)	16.0 (.630)						
	1/2	14	V5.5-14			15.0 (.591)	32.0 (1.260)	54.8 (2.157)	25.3 (.996)						
	5/8	16	V5.5-16			17.0 (.669)	32.0 (1.260)	54.8 (2.157)	25.3 (.996)						
	11/16	18	V5.5-18			19.0 (.748)	32.0 (1.260)	54.8 (2.157)	25.3 (.996)						
	3/4	20	V5.5-20			21.0 (.827)	32.0 (1.260)	54.8 (2.157)	25.3 (.996)						

Note: 1) Products with the JIS mark conform to JIS C2805.

2) \*The crimping will be more secure if the total cross-sectional area of the wire is at least 0.5 mm<sup>2</sup>.

Examples: If the cross-sectional area of the wire is 0.3 mm<sup>2</sup>, fold the wire in two when crimping the terminal.

If the cross-sectional area of the wire is 0.5 mm<sup>2</sup>, crimp the terminal onto the wire as it is.

3) The part numbers indicated in the above table are for products with a brazed seam.

When ordering products with a butted seam, add the prefix "WS" to the part number (ex. V2-4 → VWS2-4).

4) Delivery lead times may vary depending on the product. Contact JST for details.

Solderless terminals

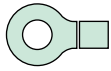

# RING TONGUE (R type) Vinyl-insulated (flared)

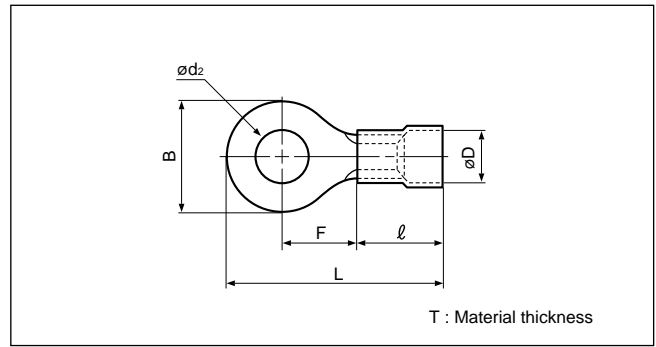
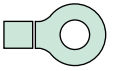

Certificate No.: E42024 LR20812 JQ0608019  
JIS C 2805

Applicable Wire AWG#(mm <sup>2</sup> )	Stud size		Part No.		Standard	Dimensions mm (in.)						Color	Tool No.	Qty/box							
	American	Metric	JST	JIS		$\phi d_2$	B	L	F	$\ell$	$\phi D$				T						
26 to 22 (0.2 to 0.5)	1-2	2	FV0.5-2			2.2 (.087)	5.2 (.205)	16.4 (.646)	5.8 (.228)	8.0 (.315)	2.9 (.114)	0.5 (.020)	Yellow	YNT-2622 YA-1 YA-2 BCT-0514L	1,000						
	3-4	3	FV0.5-3			3.2 (.126)	5.2 (.205)	16.4 (.646)	5.8 (.228)												
	5-6	3.5	FV0.5-3.7			3.7 (.146)	6.6 (.260)	19.0 (.748)	7.7 (.303)												
	8	4	FV0.5-4			4.3 (.169)	6.6 (.260)	19.0 (.748)	7.7 (.303)												
	10	5	FV0.5-5			5.3 (.209)	8.0 (.315)	19.0 (.748)	7.0 (.276)												
22 to 16 (*0.25 to 1.65)	1-2	2	FV1.25-2			2.2 (.087)	5.5 (.217)	15.7 (.618)	4.0 (.157)	9.0 (.354)	4.0 (.157)	0.8 (.031)	Red	YNT-2216 YA-1 YA-2 YA-4 BCT-0514L	1,000						
	3-4	3	FV1.25-3	RBA1.25-3		3.2 (.126)	5.5 (.217)	15.7 (.618)	4.0 (.157)												
	3-4	3	FV1.25-MS3			3.2 (.126)	5.5 (.217)	17.4 (.685)	5.6 (.220)												
	3-4	3	FV1.25-L3			3.2 (.126)	8.0 (.315)	20.0 (.787)	7.0 (.276)												
	5-6	3.5	FV1.25-3.7			3.7 (.146)	5.5 (.217)	15.7 (.618)	4.0 (.157)												
	5-6	3.5	FV1.25-M3	RBA1.25-3.5		3.7 (.146)	6.6 (.260)	18.6 (.732)	6.3 (.248)												
	8	4	FV1.25-M4			4.3 (.169)	6.6 (.260)	18.6 (.732)	6.3 (.248)												
	8	4	FV1.25-4	RBA1.25-4		4.3 (.169)	8.0 (.315)	20.0 (.787)	7.0 (.276)												
	10	5	FV1.25-5	RBA1.25-5		5.3 (.209)	8.0 (.315)	20.0 (.787)	7.0 (.276)												
	1/4	6	FV1.25-6			6.4 (.252)	11.6 (.457)	25.9(1.020)	11.1 (.437)												
	5/16	8	FV1.25-8			8.4 (.331)	11.6 (.457)	25.9(1.020)	11.1 (.437)												
16 to 14 (1.04 to 2.63)	3/8	10	FV1.25-10			10.5 (.413)	13.6 (.535)	29.7(1.169)	13.9 (.547)	9.0 (.354)	4.5 (.177)	0.8 (.031)	Blue	YNT-1614 YA-1 YA-2 YA-4 BCT-0514L	1,000						
	1-2	2	FV2-S2			2.2 (.087)	6.4 (.252)	16.5 (.650)	4.3 (.169)												
	3-4	3	FV2-MS3			3.2 (.126)	5.5 (.217)	17.4 (.685)	5.6 (.220)												
	3-4	3	FV2-S3.3			3.2 (.126)	6.4 (.252)	16.5 (.650)	4.3 (.169)												
	3-4	3	FV2-3			3.2 (.126)	8.5 (.335)	21.0 (.827)	7.8 (.307)												
	5-6	3.5	FV2-S3			3.7 (.146)	6.4 (.252)	16.5 (.650)	4.3 (.169)												
	5-6	3.5	FV2-M3	RBA2-3.5		3.7 (.146)	6.6 (.260)	18.6 (.732)	6.3 (.248)												
	5-6	3.5	FV2-P3.5			3.7 (.146)	7.0 (.276)	20.2 (.780)	7.7 (.303)												
	8	4	FV2-M4			4.3 (.169)	6.6 (.260)	18.6 (.732)	6.3 (.248)												
	8	4	FV2-P4			4.3 (.169)	7.0 (.276)	20.2 (.800)	7.7 (.303)												
	8	4	FV2-4	RBA2-4		4.3 (.169)	8.5 (.335)	21.0 (.827)	7.8 (.307)												
	10	5	FV2-M5			5.3 (.209)	8.5 (.335)	21.0 (.827)	7.8 (.307)												
	10	5	FV2-5	RBA2-5		5.3 (.209)	9.5 (.374)	21.0 (.827)	7.3 (.287)												
	1/4	6	FV2-6	RBA2-6		6.4 (.252)	12.0 (.472)	26.0(1.024)	11.0 (.433)												
	5/16	8	FV2-8	RBA2-8		8.4 (.331)	12.0 (.472)	26.0(1.024)	11.0 (.433)												
	3/8	10	FV2-10			10.5 (.413)	13.6 (.535)	29.7(1.169)	13.9 (.547)												
	1/2	12	FV2-12				13.0 (.512)	19.0 (.748)	35.2(1.386)							16.7 (.657)	13.5 (.531)	6.8 (.268)	1.0 (.039)	Yellow	YNT-1210S YA-4 BCT-0514L
1/2	14	FV2-14		15.0 (.591)	27.0(1.063)		43.7(1.720)	21.2 (.835)													
5/8	16	FV2-16		17.0 (.669)	27.0(1.063)		43.7(1.720)	21.2 (.835)													
3/4	20	FV2-20		21.0 (.827)	27.0(1.063)		43.7(1.720)	21.2 (.835)													
3-4	3	FV5.5-S3.3			3.2 (.126)		7.2 (.283)	23.0 (.906)	5.9 (.232)	13.5 (.531)	6.8 (.268)	1.0 (.039)	Yellow	YNT-1210S YA-4 BCT-0514L	500						
3-4	3	FV5.5-3			3.2 (.126)	9.5 (.374)	26.5(1.403)	8.3 (.327)													
5-6	3.5	FV5.5-S3			3.7 (.146)	7.2 (.283)	23.0 (.906)	5.9 (.232)													
5-6	3.5	FV5.5-3.7NS			3.7 (.146)	7.2 (.283)	29.2(1.149)	11.0 (.433)													
8	4	FV5.5-S4			4.3 (.169)	7.2 (.283)	23.0 (.906)	5.9 (.232)													
8	4	FV5.5-4	RBA5.5-4		4.3 (.169)	9.5 (.374)	26.5(1.043)	8.3 (.327)													
10	5	FV5.5-5	RBA5.5-5		5.3 (.209)	9.5 (.374)	26.5(1.043)	8.3 (.327)													
10	5	FV5.5-S5			5.3 (.209)	13.2 (.520)	29.1(1.146)	9.0 (.354)													
1/4	6	FV5.5-6	RBA5.5-6		6.4 (.252)	12.0 (.472)	32.5(1.280)	13.0 (.512)													
1/4	6	FV5.5-S6			6.4 (.252)	13.2 (.520)	29.1(1.146)	9.0 (.354)													
5/16	8	FV5.5-S8			8.4 (.331)	13.2 (.520)	29.1(1.146)	9.0 (.354)													
5/16	8	FV5.5-8	RBA5.5-8		8.4 (.331)	15.0 (.591)	34.7(1.366)	13.7 (.539)													
3/8	10	FV5.5-10	RBA5.5-10		10.5 (.413)	15.0 (.591)	34.7(1.366)	13.7 (.539)													
1/2	12	FV5.5-12				13.0 (.512)	19.2 (.756)	39.1(1.539)	16.0 (.630)							13.5 (.531)	6.8 (.268)	1.0 (.039)	Yellow	YNT-1210S YA-4 BCT-0514L	500
1/2	14	FV5.5-14				15.0 (.591)	32.0(1.260)	54.8(2.157)	25.3 (.996)												
5/8	16	FV5.5-16				17.0 (.669)	32.0(1.260)	54.8(2.157)	25.3 (.996)												
11/16	18	FV5.5-18				19.0 (.748)	32.0(1.260)	54.8(2.157)	25.3 (.996)												
3/4	20	FV5.5-20		21.0 (.827)		32.0(1.260)	54.8(2.157)	25.3 (.996)													

- Note: 1) Products with the JIS mark conform to JIS C2805.  
 2) \*The crimping will be more secure if the total cross-sectional area of the wire is at least 0.5 mm<sup>2</sup>.  
 Examples: If the cross-sectional area of the wire is 0.3 mm<sup>2</sup>, fold the wire in two when crimping the terminal.  
 If the cross-sectional area of the wire is 0.5 mm<sup>2</sup>, crimp the terminal onto the wire as it is.  
 3) The part numbers indicated in the above table are for products with a brazed seam.  
 When ordering products with a butted seam, add the prefix "WS" to the part number (ex. FV2-4 → **FVWS2-4**).  
 4) Delivery lead times may vary depending on the product. Contact JST for details.

Solderless terminals

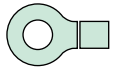

**RING TONGUE (R type) vinyl-insulated (funnel-entry)**

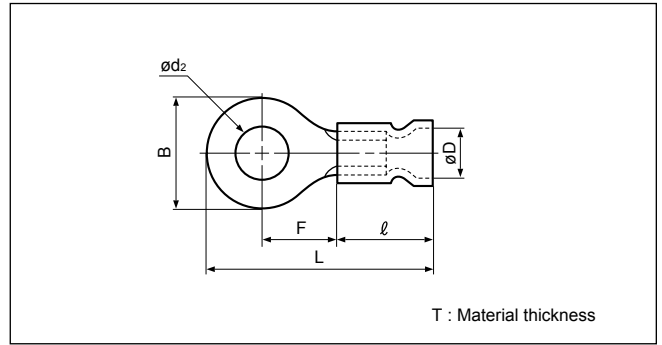
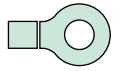

Certificate No.: E42024 LR20812

Applicable Wire AWG#(mm <sup>2</sup> )	Stud size		Part No.	Standard	Dimensions mm (in.)							Color	Tool No.	Qty/box
	American	Metric			$\phi d_2$	B	L	F	$\ell$	$\phi D$	T			
22 to 16 *(0.25 to 1.65)	3-4	3	FVX1.25-3		3.2 (.126)	5.5 (.217)	17.5 (.689)	4.0 (.157)	10.8 (.425)	4.0 (.157)	0.8 (.031)	Red	YNT-2216 YA-1 YA-2 YA-4 BCT-0514L	1,000
	3-4	3	FVX1.25-MS3		3.2 (.126)	5.5 (.217)	19.2 (.756)	5.6 (.221)						
	5-6	3.5	FVX1.25-M3		3.7 (.146)	6.6 (.260)	20.4 (.803)	6.3 (.248)						
	8	4	FVX1.25-M4		4.3 (.169)	6.6 (.260)	20.4 (.803)	6.3 (.248)						
	8	4	FVX1.25-4		4.3 (.169)	8.0 (.315)	21.8 (.858)	7.0 (.276)						
	10	5	FVX1.25-5		5.3 (.209)	8.0 (.315)	21.8 (.858)	7.0 (.276)						
16 to 14 (1.04 to 2.63)	3-4	3	FVX2-MS3		3.2 (.126)	5.5 (.217)	19.2 (.756)	5.6 (.221)	10.8 (.425)	4.6 (.181)	0.8 (.031)	Blue	YNT-1614 YA-1 YA-2 YA-4 BCT-0514L	1,000
	5-6	3.5	FVX2-S3		3.7 (.146)	6.4 (.252)	18.3 (.720)	4.3 (.169)						
	5-6	3.5	FVX2-M3		3.7 (.146)	6.6 (.260)	20.4 (.803)	6.3 (.248)						
	8	4	FVX2-M4		4.3 (.169)	6.6 (.260)	20.4 (.803)	6.3 (.248)						
	8	4	FVX2-4		4.3 (.169)	8.5 (.335)	22.8 (.898)	7.8 (.307)						
	10	5	FVX2-5		5.3 (.209)	9.5 (.374)	22.8 (.898)	7.3 (.287)						
	1/4	6	FVX2-6		6.4 (.252)	12.0 (.472)	27.8(1.094)	11.0 (.433)						
12 to 10 (2.63 to 6.64)	3-4	3	FVX5.5-3		3.2 (.126)	9.5 (.374)	27.0(1.063)	8.3 (.327)	14.0 (.551)	6.8 (.268)	1.0 (.039)	Yellow	YNT-1210S YA-4 BCT-0514L	500
	10	5	FVX5.5-5		5.3 (.209)	9.5 (.374)	27.0(1.063)	8.3 (.327)						
	10	5	FVX5.5-S5		5.3 (.209)	13.2 (.520)	29.6(1.165)	9.0 (.354)						
	5/16	6	FVX5.5-S6		6.4 (.252)	13.2 (.520)	29.6(1.165)	9.0 (.354)						
	3/8	8	FVX5.5-8		8.4 (.331)	15.0 (.591)	35.2(1.386)	13.7 (.539)						

- Note:1) The part numbers indicated in the above table are for products with a brazed seam.  
 When ordering products with a butted seam, add the prefix "WS" to the part number (ex. FVX2-4 →FVXWS2-4).  
 2) \*The crimping will be more secure if the total cross-sectional area of the wire is at least 0.5 mm<sup>2</sup>.  
 Examples : If the cross-sectional area of the wire is 0.3 mm<sup>2</sup>, fold the wire in two when crimping the terminal.  
 If the cross-sectional area of the wire is 0.5 mm<sup>2</sup>, crimp the terminal onto the wire as it is.  
 3) Delivery lead times may vary depending on the product. Contact JST for details.