

HCM CONNECTOR

Board-to-wire/Wire-to-wire

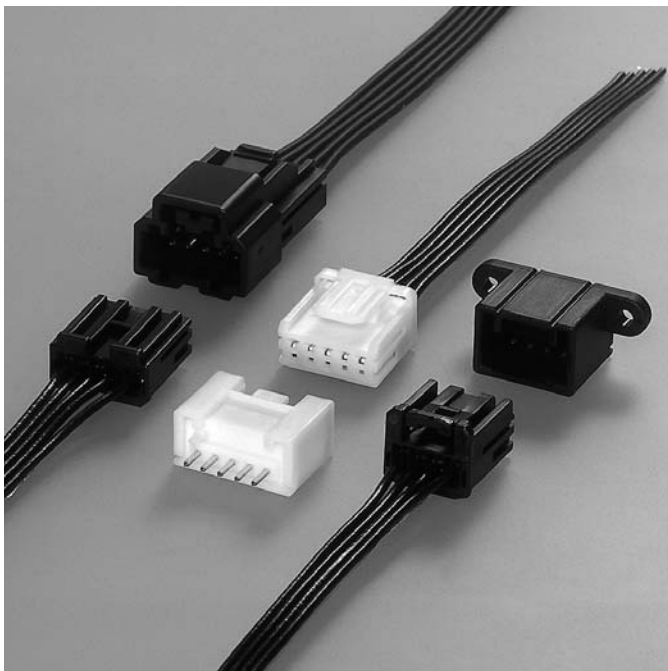

0.64 unsealed, low profile, miniaturized connectors for automobile applications.

Meets or exceeds the major performance specifications for automotive electrical connector systems.

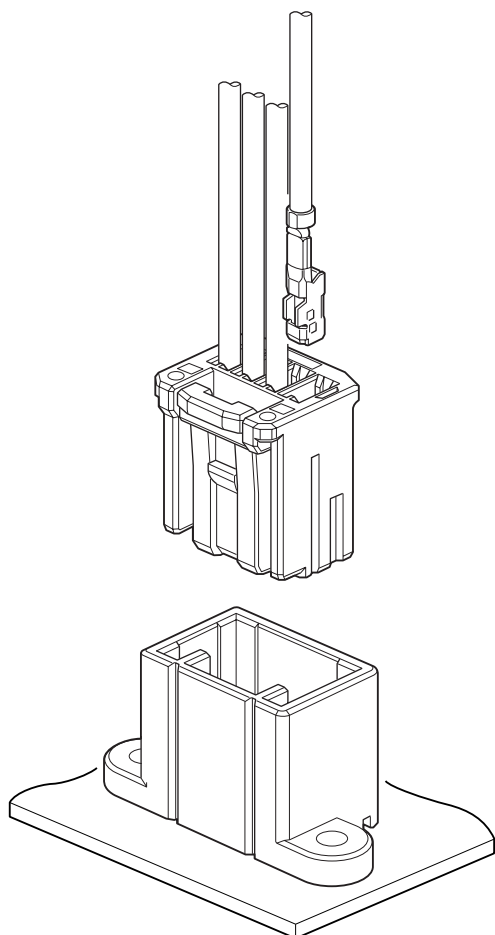

Features

- Miniaturized Connectors, Compliant with the Automotive Performance Specifications
- Boxed Female Terminal with Triple Over-stress Protection Mechanism
- Accept 0.64 or 1.0 mm Male Blade
- Optional Connector Position Assurance (CPA) Design
- Terminal Independent Secondary Lock
- Variations
Multiple circuits sizes and circuit board locking mechanisms available to suit your needs.

Specifications

- Current rating: 5 A DC
- Voltage rating: 14 V DC
- Temperature range: -40°C to +100°C
(including temperature rise in applying electrical current)
- Contact resistance: Initial value/ 20 mΩ max.
After environmental tests/ 20 mΩ max.
- Insulation resistance: 20 MΩ min.
- Applicable wire: SAE/ AVSS/ CAVS
0.3 mm² to 0.5 mm²
: UL Cable
0.21 mm²

- * Compliant with ELV/RoHS.
- * Contact JST for details.

Female terminal

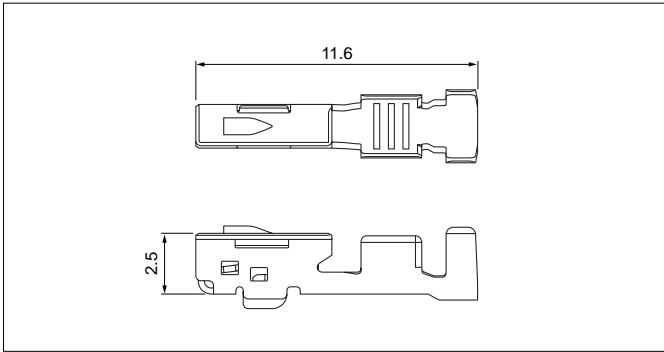

Model No.	Applicable wire range		Q'ty/reel
	Conductor (mm ²)	Insulation O.D. (mm)	
SHCM-A03T-P025	0.3 to 0.5	1.4 to 1.9	5,000
SHCM-A04T-P025	0.21	1.5	5,000

Material and Finish

Copper alloy, tin-plated

Female connector

Single row

Inner lock type

• 3 circuits

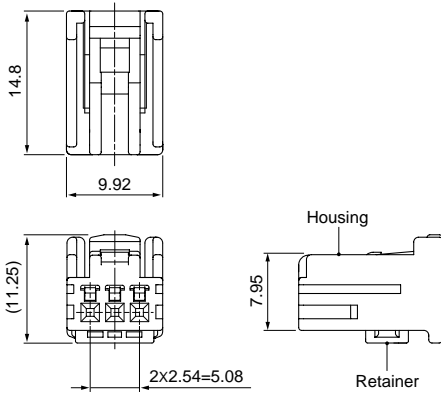

• 4 circuits

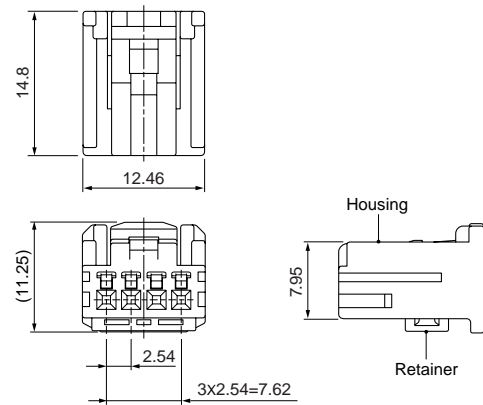

• 5 circuits

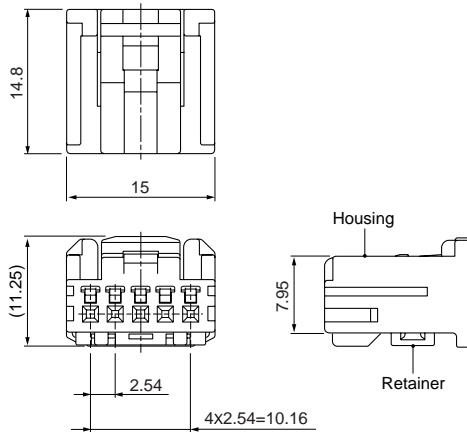

• 6 circuits

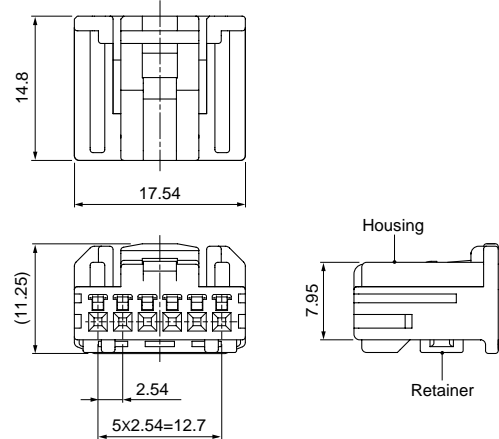

• 12 circuits

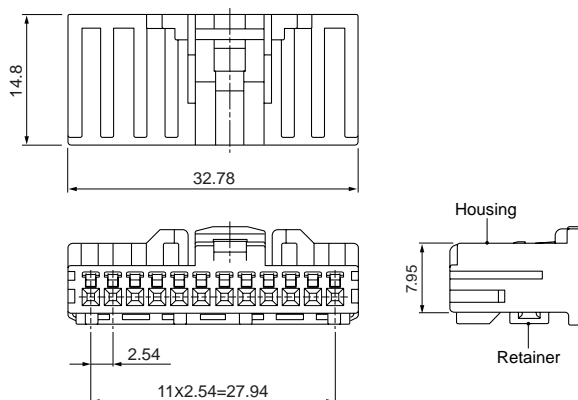

Female connector

Single row

Inner lock type

- 6 circuits (W/CPA type)

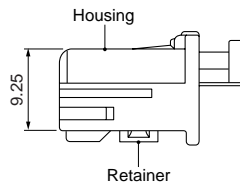
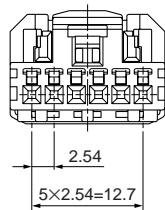
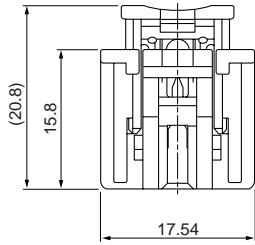

Outer lock type

- 5 circuits

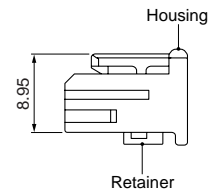
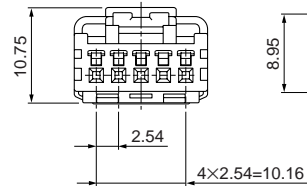
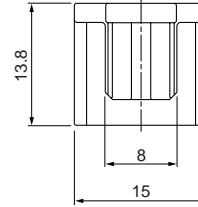

Dual row

Inner lock type

- 8 circuits

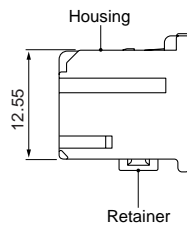
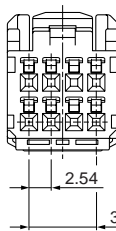
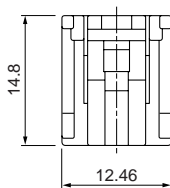

- 9 circuits

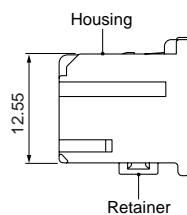
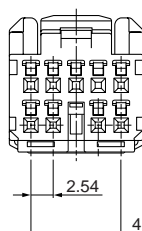
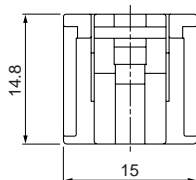

Single row

Type	Circuits	Model No.	Q'ty/box	Housing Color
Inner lock	3	HCMPB-03-K	800	Black
		HCMPB-03-S	800	White
	4	HCMPB-04-K	600	Black
		HCMPB-04-H	600	Gray
		HCMPB-04-S	600	Natural (White)
	5	HCMPB-A05-K	500	Black
		HCMPB-A05-S	500	Natural (White)
	6	HCMPB-06-K	400	Black
		HCMPB-06-S	400	Natural (White)
	12	HCMPB-12-K	200	Black
*12	HCMPB-A12-K	200	Black	
Inner lock (W/CPA)	6	HCMPB-C06A-K	300	Black
		HCMPB-C06A-S	300	Natural (White)
Outer lock	5	HCMPB-05-K	500	Black
		HCMPB-05-S	500	Natural (White)

Material and Finish

Housing: PBT

Retainer: PBT, Blue

CPA (Only for 6 circuits with CPA): Glass-filled PBT, Red

*Additional keying

Dual row

Circuits	Model No.	Q'ty/box	Housing Color
8	HCMDPB-08-K	400	Black
	HCMDPB-08-S	400	Natural (White)
9	HCMDPB-09-K	400	Black

Material and Finish

Housing: PBT

Retainer: PBT, Blue

Male connector (Top entry type)

Inner lock type

● 3 circuits

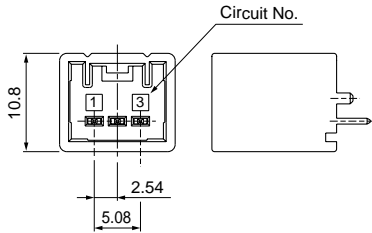
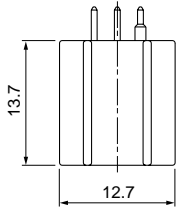

● 5 circuits

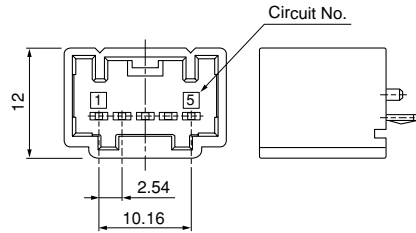
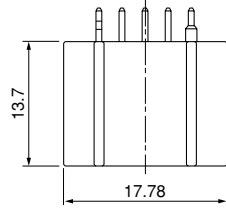

● 6 circuits

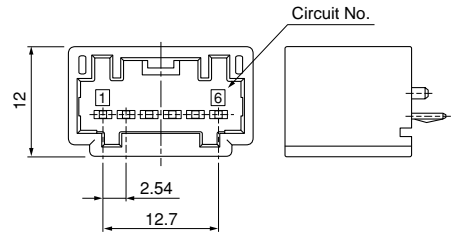
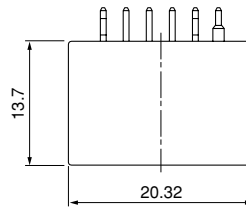

Screw hole

● 4 circuits

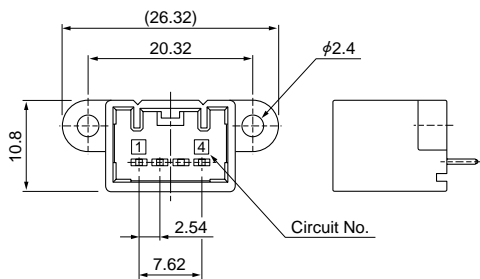
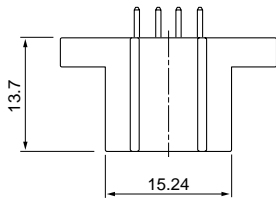

● 5 circuits

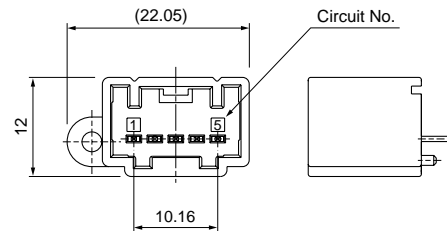
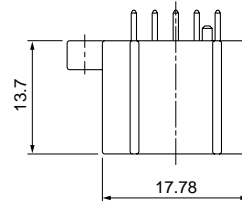

Outer lock type

● 5 circuits

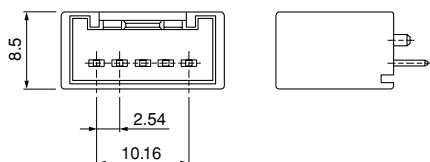
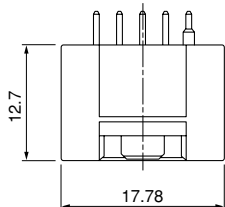

Type	Circuits	Model No.	Q'ty/box	Housing Color
Inner lock	3	B03B-HCMKS	480	Black
		B03B-HCMSS	480	Natural (White)
	5	B05B-AHCMKK	288	Black
		B05B-AHCMKS	288	Natural (White)
	6	B06B-HCMKK	240	Black
		B06B-HCMKS	240	Natural (White)
Inner lock (Screw hole)	4	B04B-HCMKS-R	240	Black
		B04B-HCMKS-RA	240	Black
		B04B-HCMKS-2R	240	Black
	5	B05B2-AHCMKS-A	270	Black
Outer lock	5	B05B-HCMKS-R	432	Black
		B05B-HCMSS-R	432	Natural (White)

Material and Finish

Housing: Glass-filled PBT

Pin: Brass, tin-plated

HCM CONNECTOR

Male connector (Side entry type)

Reinforcement type

● 3 circuits (S03B1-HCMKS)

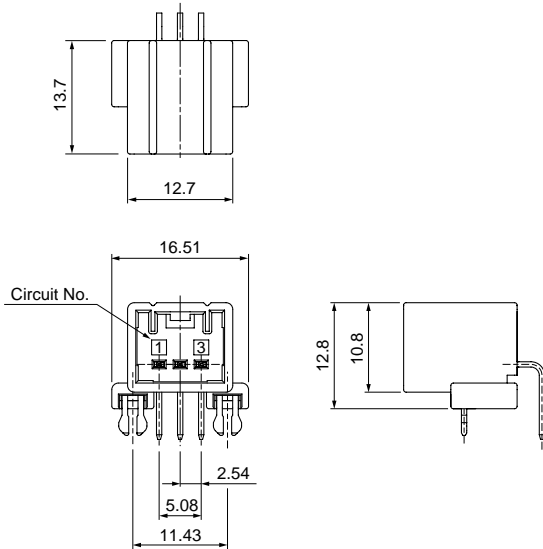

● 3 circuits (S04B1A-HCMKS)

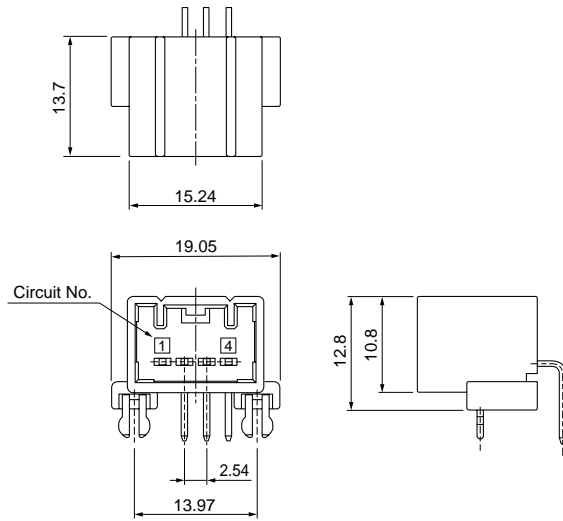

● 4 circuits

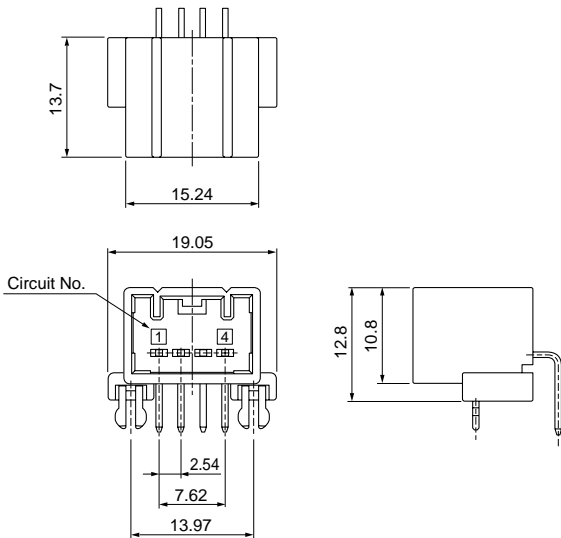

Circuits	Model No.	Q'ty/box	Housing Color
3	S03B1-HCMKS	180	Black
	S04B1A-HCMKS	165	Black
4	S04B1-HCMKS	165	Black
	S04B1-HCMSS	165	Natural (White)

Material and Finish

Housing: Glass-filled PBT
Pin: Brass, tin-plated

Male terminal

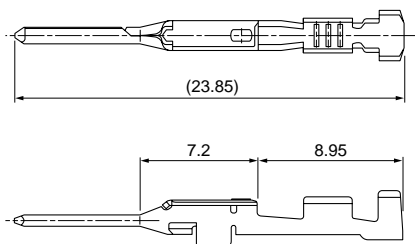

Model No.	Applicable wire range		Q'ty/reel
	Conductor (mm ²)	Insulation O.D. (mm)	
SHCMW-A03T-040	0.3 to 0.5	≤1.9	5,000

Material and Finish

Brass, tin-plated (reflow treatment)

Male connector (Wire-to-wire)

Single row ● 5 circuits

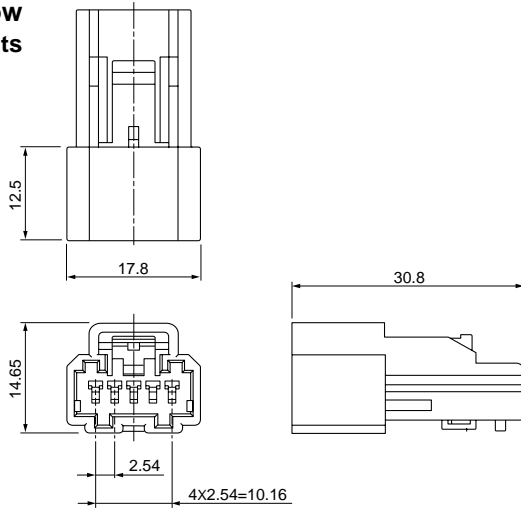

Dual row ● 4 circuits

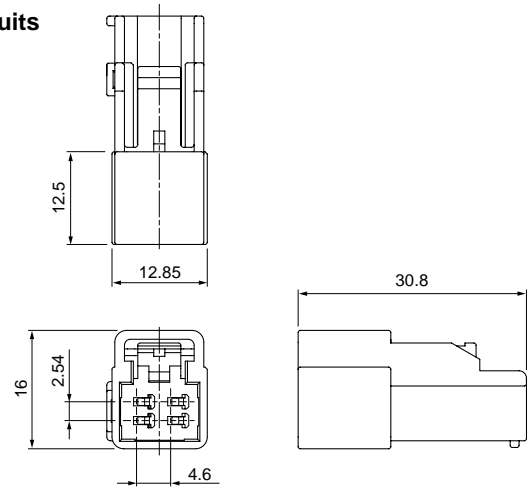

● 6 circuits

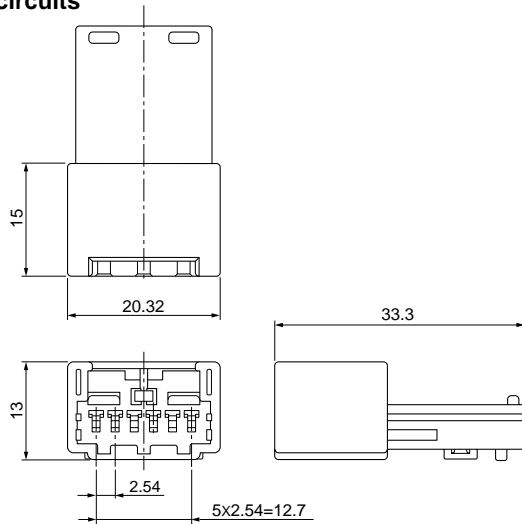

Type	Circuits	Model No.	Q'ty/box	Housing Color
Single row	5	HCMWSB-05-K	200	Black
	6	HCMWSB-C06-K	200	Black
Dual row	4	HCMDWSB-04-S	250	Natural (White)

Material and Finish
Housing: PBT
Retainer: PBT, Blue

Female connector

Single row ● 5 circuits

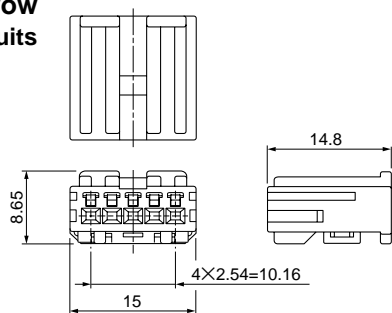

Dual row ● 4 circuits

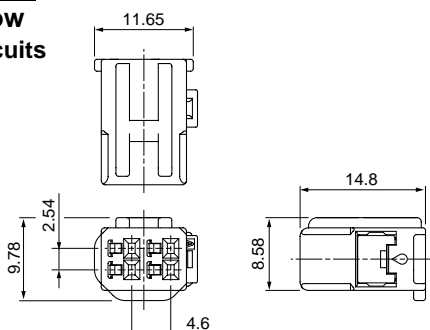

Type	Circuits	Model No.	Q'ty/box	Housing Color
Single row	5	HCMWPB-05-K	500	Black
Dual row	4	HCMDWPB-04-S	850	Natural (White)
		HCMDWPB-04-K	850	Black

Material and Finish
Housing: PBT
Retainer: PBT, Blue

HCM CONNECTOR

PC board layout

Top entry type

• 3 circuits

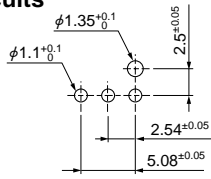

• 5 circuits

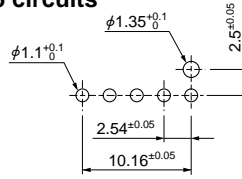

• 6 circuits

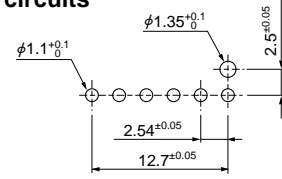

• 4 circuits (with screw hole)

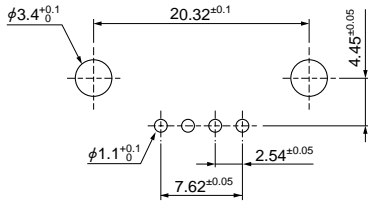

• 5 circuits (with screw hole)

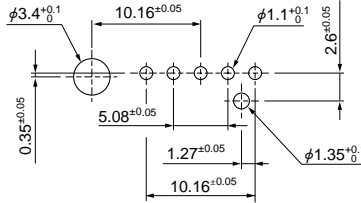

Side entry type (with reinforcement)

• 3 circuits

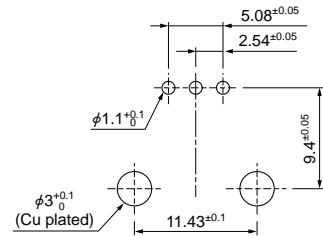

• 3 circuits (with 4 circuits housing)

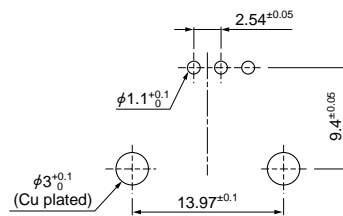

• 4 circuits

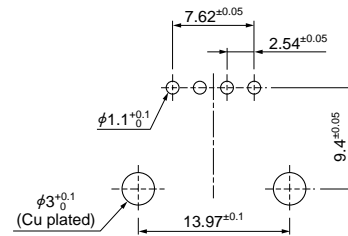

Note: 1. Tolerances are non-cumulative.

2. Hole dimensions differ according to the type of PC board and piercing method. The dimensions above should serve as guideline. Contact JST for details.

Assembly layout

Top entry type

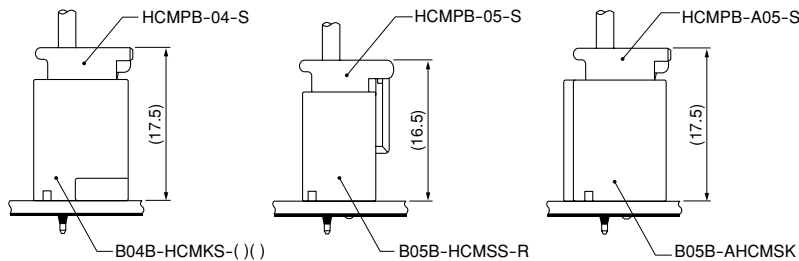

Side entry type

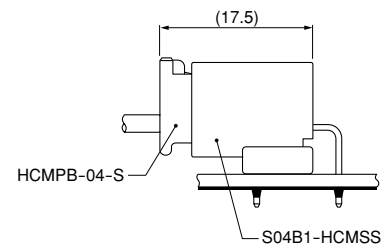

Wire-to-wire type

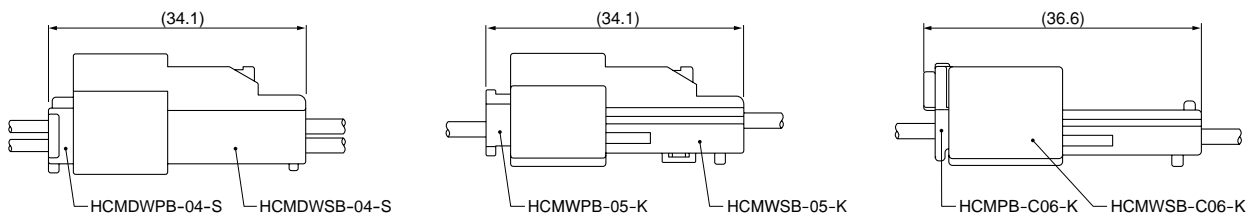

Crimping machine, Applicator

Strip terminal	Crimping machine	Crimp applicator MKS-L	
		Dies	Crimp applicator with dies
SHCM-A03T-P025	AP-K2N	MK/SHCM-A03-025	APLMK SHCM-A03-025
SHCM-A04T-P025		MK/SHCM-A04-025	APLMK SHCM-A04-025
SHCMW-A03T-040		MK/SHCMW-A03-040	APLMK SHCMW-A03-040

Note: When crimping operation is conducted using an applicator and die set other than the above, JST cannot guarantee the performance of the terminal.