

DRAWING FOR REFERENCE: This is subject to change without notice
05/31/2013

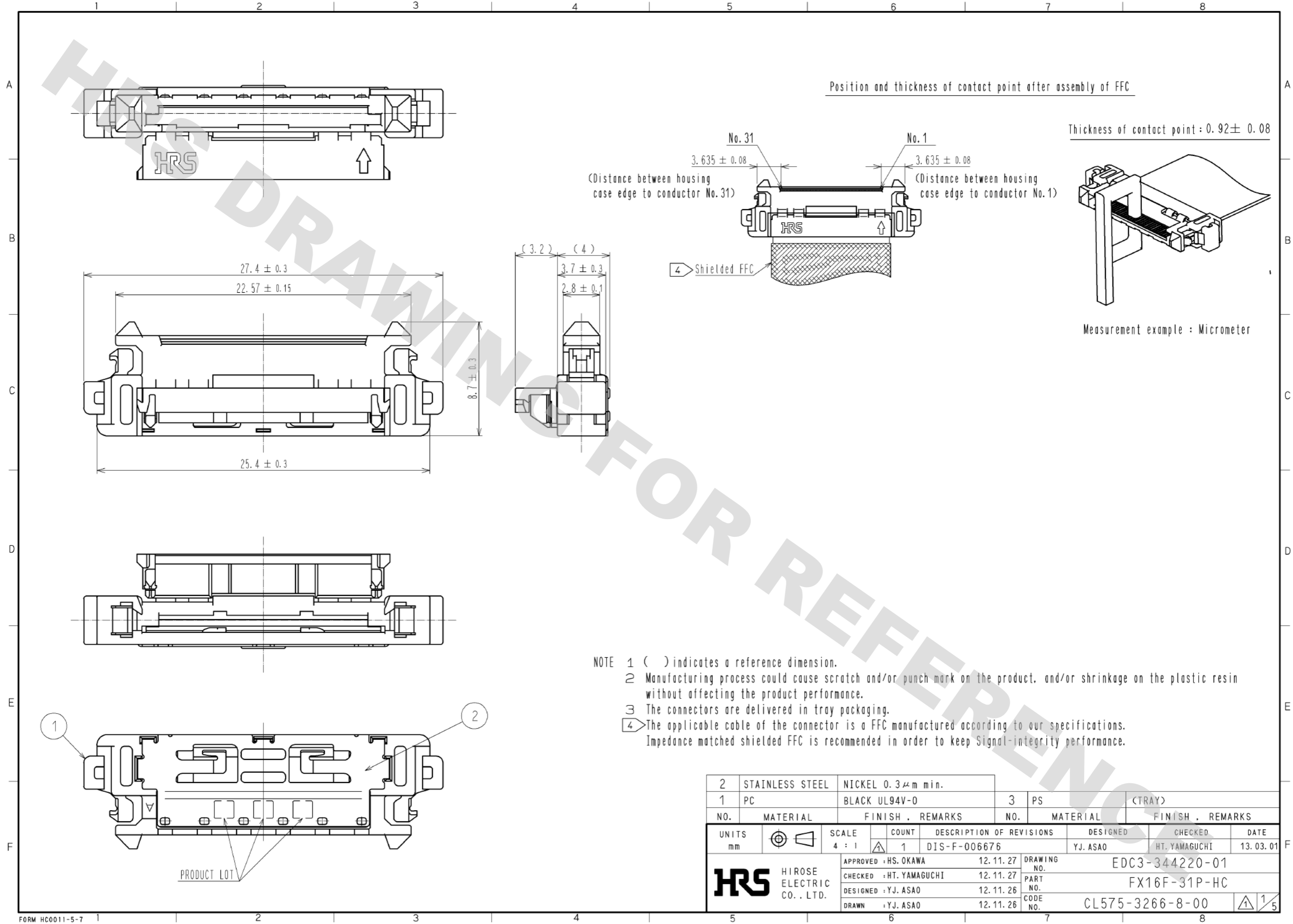

- NOTE 1 () indicates a reference dimension.
 2 Manufacturing process could cause scratch and/or punch mark on the product, and/or shrinkage on the plastic resin without affecting the product performance.
 3 The connectors are delivered in tray packaging.
 4 The applicable cable of the connector is a FFC manufactured according to our specifications. Impedance matched shielded FFC is recommended in order to keep Signal-integrity performance.

| 2 | STAINLESS STEEL | NICKEL 0.3 μm min. | 3 | PS | (TRAY) |
|-------------------------|-----------------|--------------------------|------------|-----------------|------------------|
| 1 | PC | BLACK UL94V-0 | | | |
| NO. | MATERIAL | FINISH . REMARKS | NO. | MATERIAL | FINISH . REMARKS |
| UNITS | mm | SCALE | 4 : 1 | COUNT | 1 |
| | | DESCRIPTION OF REVISIONS | | DESIGNED | Y.J. ASAO |
| | | DIS-F-006676 | | CHECKED | HT. YAMAGUCHI |
| | | DATE | | 13. 03. 01 | |
| APPROVED : HS. OKAWA | | | 12. 11. 27 | | |
| CHECKED : HT. YAMAGUCHI | | | 12. 11. 27 | | |
| DESIGNED : YJ. ASAO | | | 12. 11. 26 | | |
| DRAWN : YJ. ASAO | | | 12. 11. 26 | | |
| DRAWING NO. | | | | EDC3-344220-01 | |
| PART NO. | | | | FX16F-31P-HC | |
| CODE NO. | | | | CL575-3266-8-00 | |
| | | | | 1/5 | |

DRAWING FOR PACKING(1:2)

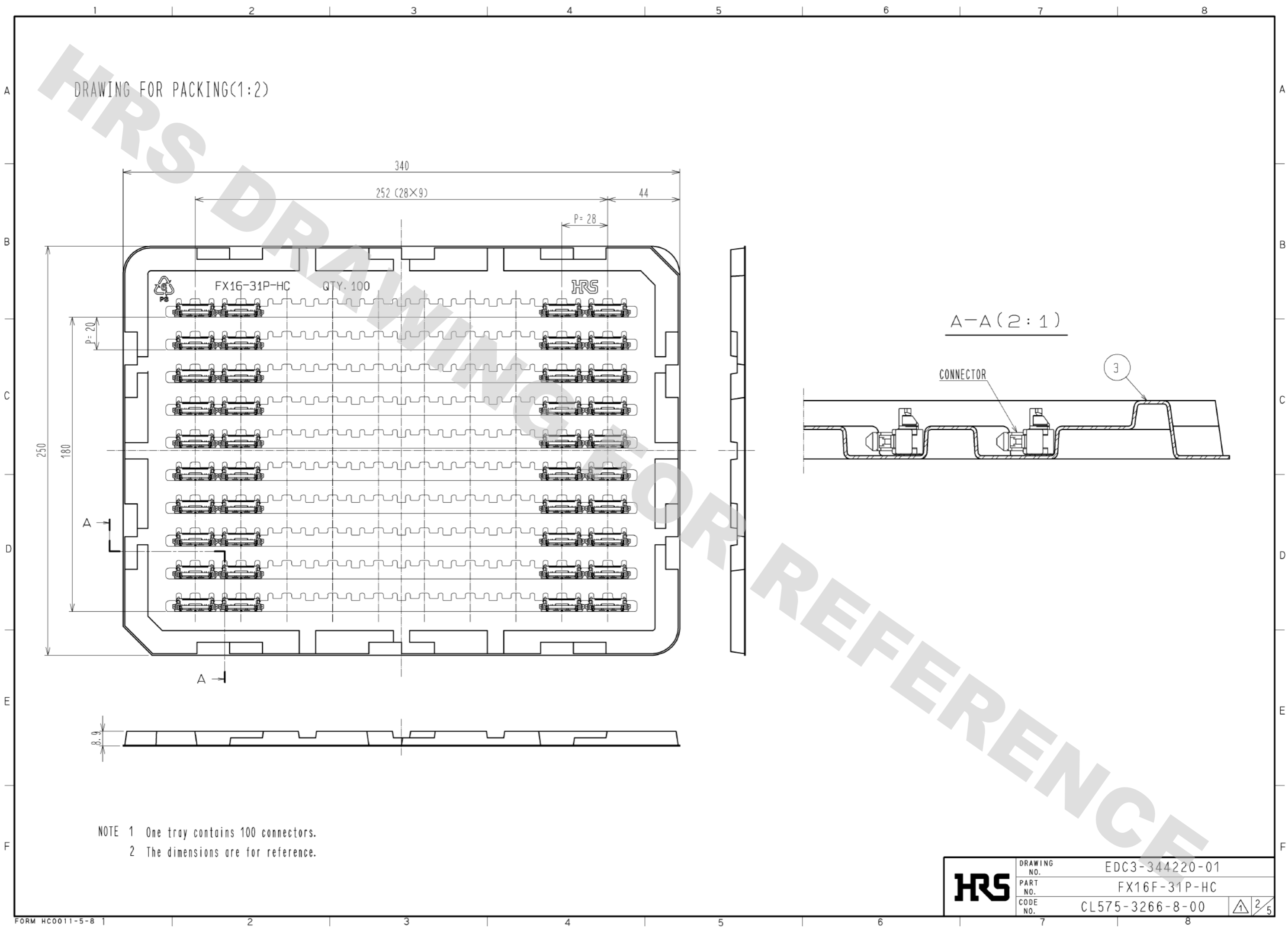

- NOTE 1 One tray contains 100 connectors.
 2 The dimensions are for reference.

| | | |
|------------|-------------|-----------------|
| HRS | DRAWING NO. | EDC3-344220-01 |
| | PART NO. | FX16F-31P-HC |
| | CODE NO. | CL575-3266-8-00 |
| | | 2/5 |

DRAWING FOR REFERENCE: This is subject to change without notice
05/31/2013

HANDLING INSTRUCTIONS

[1] Insertion to on-board connector

The connector mating is keyed. Align the marks as shown in the figure for mating. Insert the connector completely until they are locked at both ends.

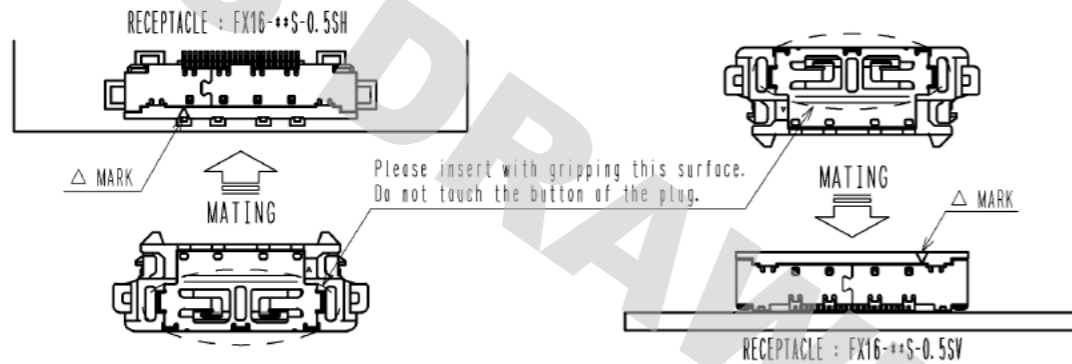

The connectors have a reverse-insertion prevention structure. However, the connectors may be damaged when inserted reversely with the force of 25N or more. Avoid a forceful insertion and make sure to confirm that the connectors are aligned with the marks before the mating operation.

[2] After mating

Carefully wire FFC, so that excessive force will not be applied to the mated connector. Pulling the FFC with the force of 10N or more may damage the connector. It may also cause FFC breakage. Take a caution to avoid pulling the FFC.

Repetitive FFC strokes could also cause FFC breakage as well. Do not use the connector under the environment of repetitive FFC strokes.

Take enough bend radius and/or distance from the connector for FFC not to apply stress to the connector base when the application requires FFC bend back.

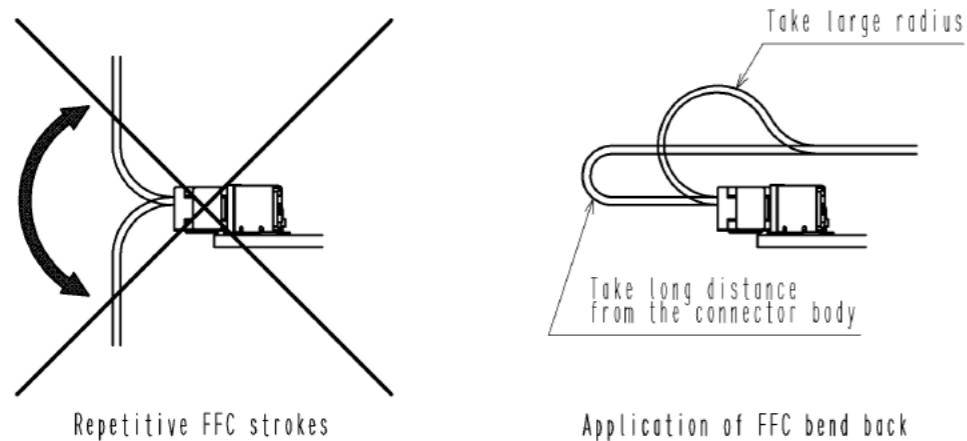

[3] Withdrawal from on-board connector

The connectors are locked while they are mated. In order to unmate the connectors, pull out straight with the button pushed to release the lock. At this time, do not pull the FFC. Also avoid the withdrawal in angle, which may damage the connectors.

<Correct withdrawal>

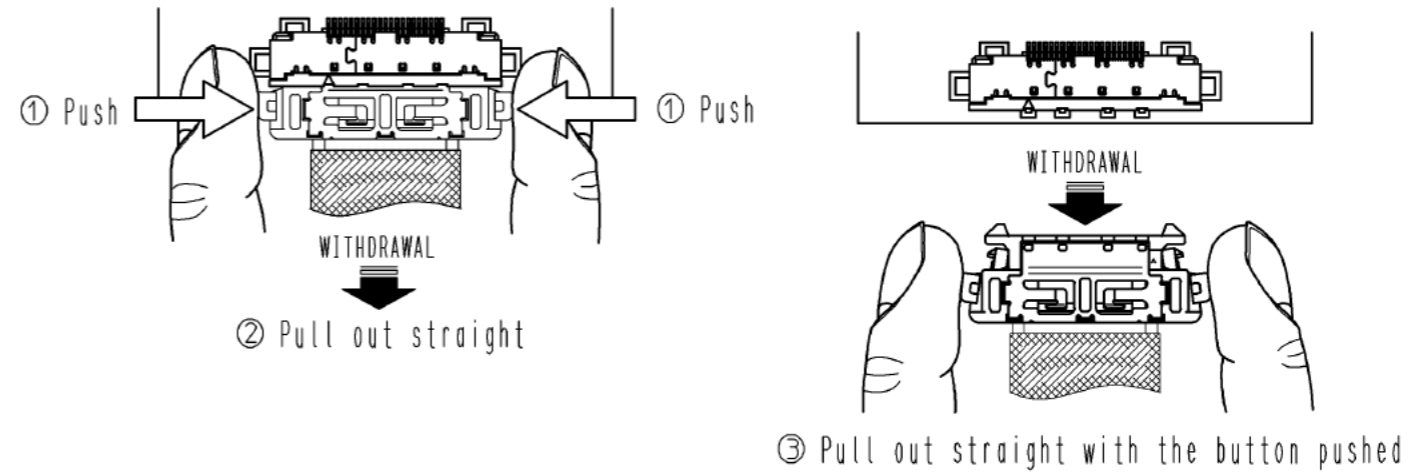

<Incorrect withdrawal>

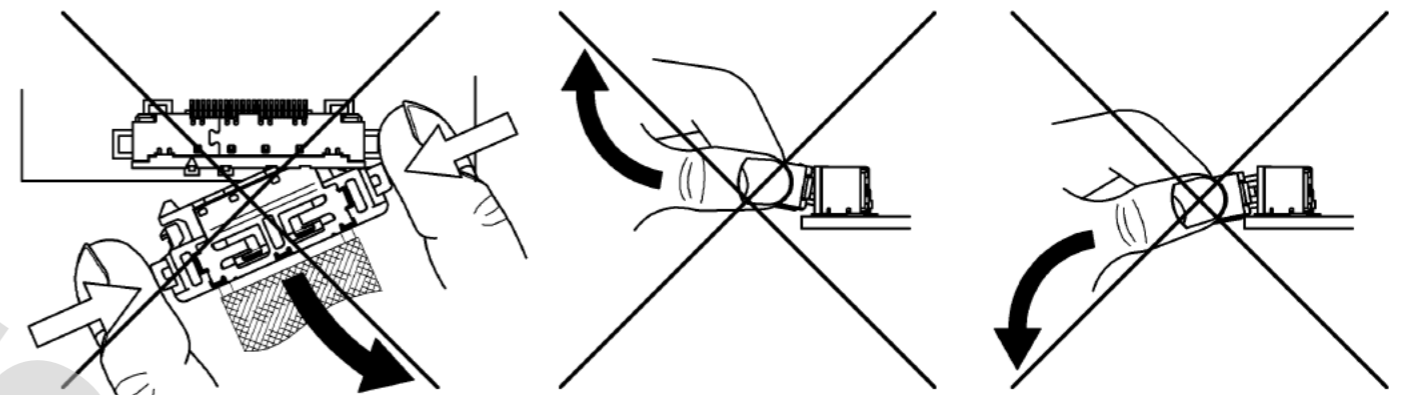

[4] For the case that connector is withdrawn in condition that lock on one side is locked

In case connector is withdrawn in condition that lock on one side is locked, it could damage the locking part. In such case, do not withdraw forcefully, but mate the plug again and pull out the plug in condition that the two locks are locked and withdraw with <Correct withdrawal> method.

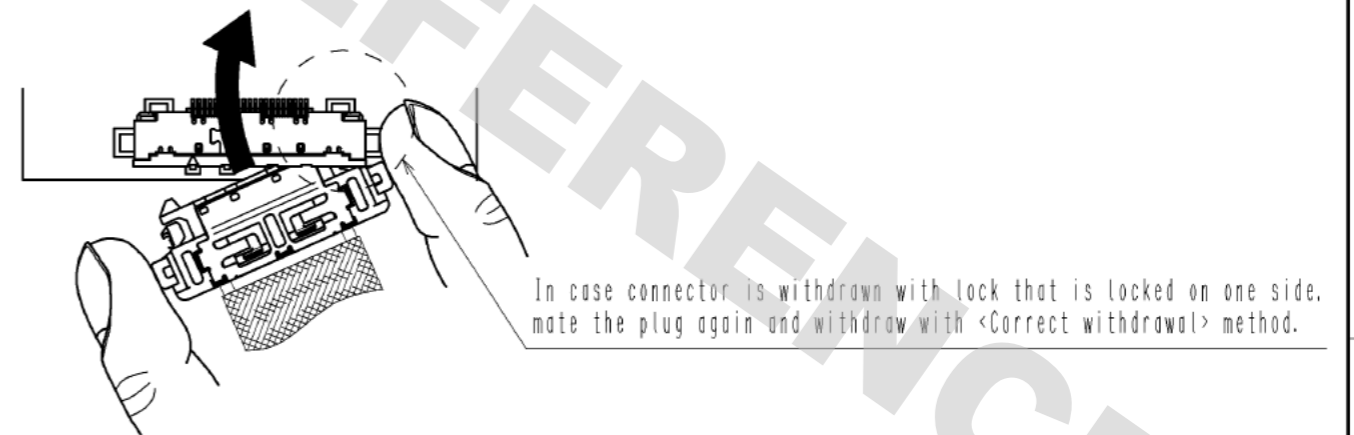

*Note : The connectors shown in this 'HANDLING INSTRUCTIONS' are drawn for the instruction purpose. Therefore, the appearance differs from the actual connectors. Please confirm the connector configuration on the connector drawing (SHEET 1).

| | | |
|------------|-------------|-----------------|
| HRS | DRAWING NO. | EDC3-344220-01 |
| | PART NO. | FX16F-31P-HC |
| | CODE NO. | CL575-3266-8-00 |
| | | 3/5 |

DRAWING FOR REFERENCE: This is subject to change without notice 05/31/2013

Please read the notification below before handling the connector.

PRECAUTION FOR HARNESS

*Please make sure not to touch conductor of FFC.

[1] How to insert FFC

FFC needs to be inserted straight in alignment with mold lib as shown on illustration below.
 In case FFC is inserted wrong direction, FFC can not be inserted.
 In the worst case, FFC will be deformed, plastic housing, spring terminal will be broken, so please be aware of these points.

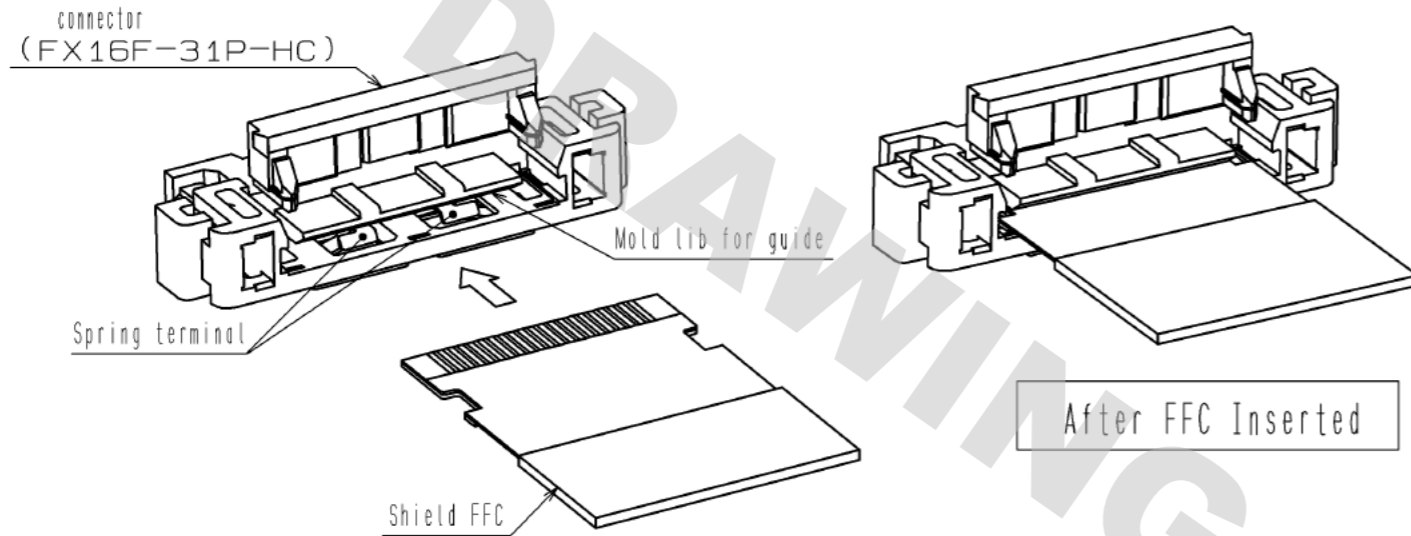

[2] How to check FFC inserted position

Verify that the position of FFC end face from directly above to check whether FFC inserted to correct position.
 When inserted correctly, the end of FFC is visible through the square holes in the plastic housing.
 *Please check that the end of FFC hits the wall of the plastic housing.

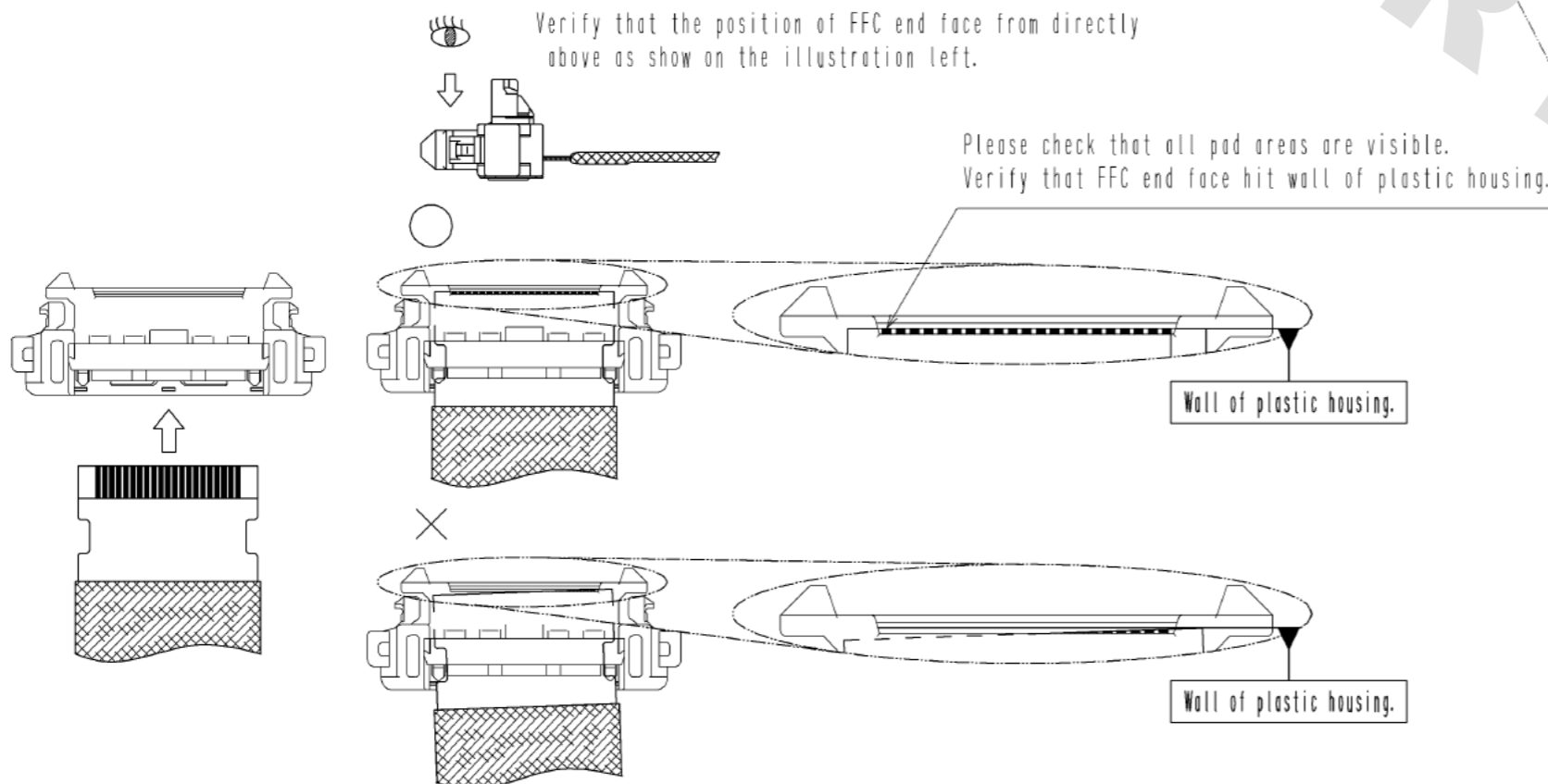

[3] How to fix FFC

Hold the connector with both hands and put the thumb near the fook of both sides of the hinged actuator as shown in the figure below.
 Then push down both sides of the hinged actuator at the same time.
 After closing hinged actuator, hold both sides of the plastic housing and pull the FFC to FFC layout direction by 3 to 5N, then verify that FFC does not comes off from the plastic housing and fit to both side hooks completely.

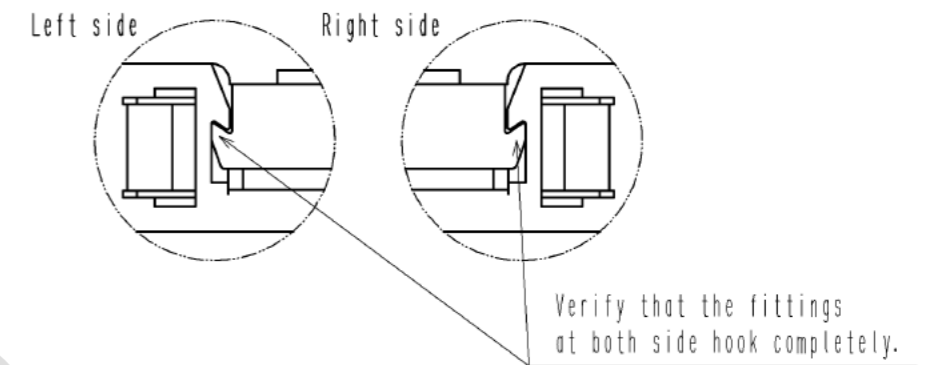
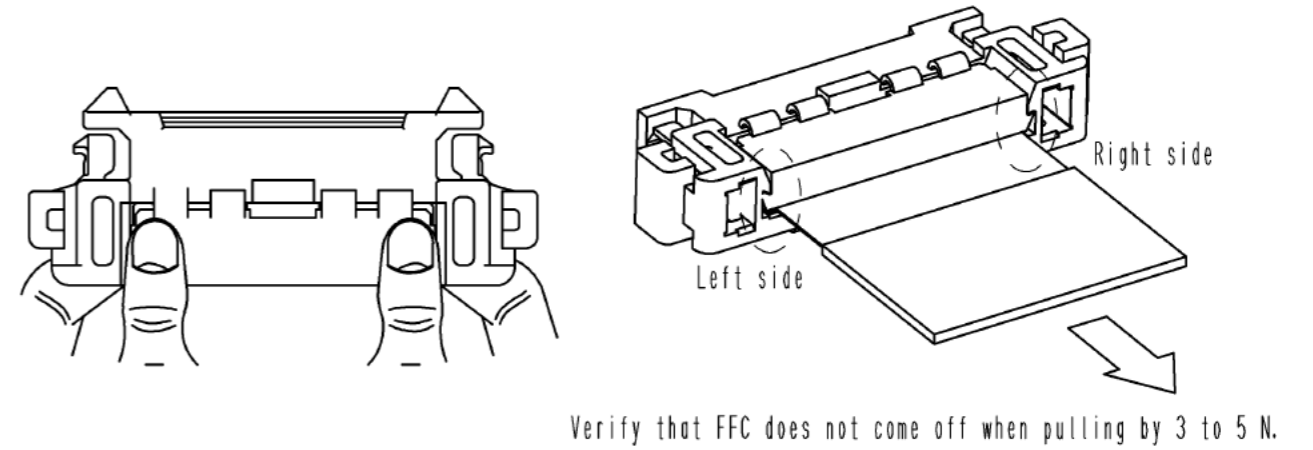

[4] Other precautions

① Do not apply forces to the hinged actuator to the direction as shown below, and also avoid closing it to the locked position until the correct process in cable assembly. Do not use the connector when this happens.

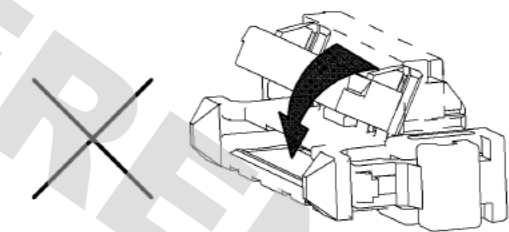

② Once removing the FFC from the plug housing after cable assembly, do not reuse.
 ③ For the packing of the plug after cable assembly, do not damage and/or deform the product.

*Note : The connectors shown in this 'PRECAUTION FOR HARNESS' are drawn for the instruction purpose. Therefore, the appearance differs from the actual connectors. Please confirm the connector configuration on the connector drawing (SHEET 1).

| | | |
|------------|-------------|-----------------|
| HRS | DRAWING NO. | EDC3-344220-01 |
| | PART NO. | FX16F-31P-HC |
| | CODE NO. | CL575-3266-8-00 |
| | | 4/5 |

DRAWING FOR REFERENCE: This is subject to change without notice
05/31/2013

Applicable FFC dimensions

A (20 : 1)

B (20 : 1)

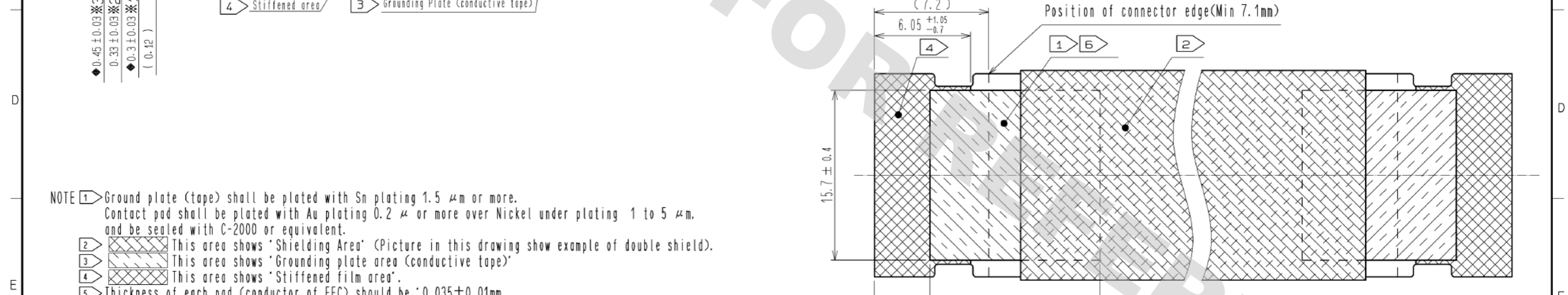
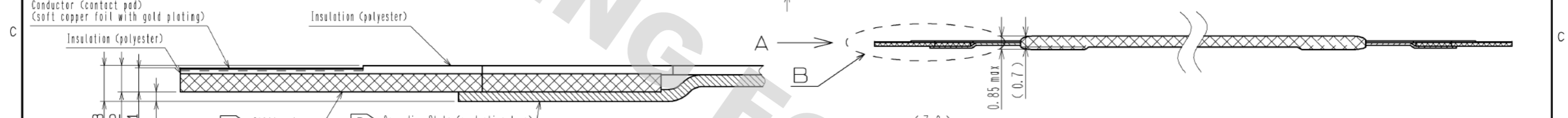
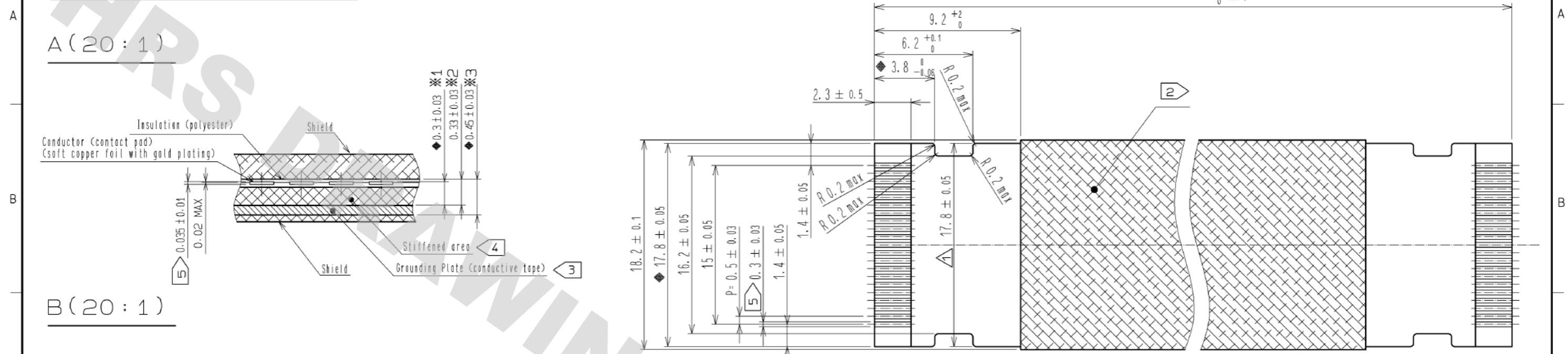

- NOTE
- 1 Ground plate (tape) shall be plated with Sn plating 1.5 μm or more. Contact pad shall be plated with Au plating 0.2 μm or more over Nickel under plating 1 to 5 μm, and be sealed with C-2000 or equivalent.
 - 2 This area shows 'Shielding Area' (Picture in this drawing show example of double shield).
 - 3 This area shows 'Grounding plate area (conductive tape)'
 - 4 This area shows 'Stiffened film area'.
 - 5 Thickness of each pad (conductor of FFC) should be 0.035 ± 0.01mm, and width of each pad (conductor of FFC) should be 0.3 ± 0.03mm.
 - 6 The shielding should be laid on the ground plate (tape). Please make sure if there is conductivity between the ground plate (tape) on one side of the FFC and the other.
 - 7 The differential impedance of this FFC should be 100 ohm ± 7%.
 - 8 The rated current of this FFC should be 0.5A per pad. The rated voltage of this FFC should be 60V. The upper temperature limit of this FFC should be 105 degrees Centigrade.
 - 9 When dimensions are written in (), it means they are 'Dimensions for reference'. When dimensions are written with ※, it means they are 'Duplicated dimensions'. When dimensions are written with ◆, it means they are 'Important dimensions'.
 - 10 Dimension L is the cable length between the cable exit of each connector.
 - 11 Total length of FFC is 'connector length 7.2mm' x 2 + L mm.

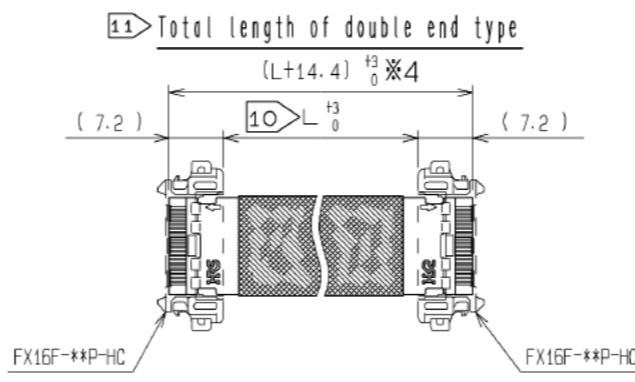

| | | |
|------------|-------------|-----------------|
| HRS | DRAWING NO. | EDC3-344220-01 |
| | PART NO. | FX16F-31P-HC |
| | CODE NO. | CL575-3266-8-00 |
| | | 5/5 |

DRAWING FOR REFERENCE: This is subject to change without notice 05/31/2013