

POWER.S³ RCS800 HIGH VOLTAGE - 230 A 2 way Connectors

Features & benefits

Electrical features

- High voltage 400-750 V
- High current carrying capacity: 230 A at 70°C with 50mm² wire section

Shielding performances

- EMI/RFI 60 dB Shielding protection at 100 MHz

Mechanical features

- FCI ErgoMate® Axial Mating Assist System on female connector
- Easy handling
- Reduced mating forces
- 2-step disconnection feature for safe unmating
- Unique integrated electric interlock
- CPA (Connector Position Assurance)

Terminal system

- New RCS800 compact 8mm round terminals complying to high electrical performances

Environmental features

- Dual sealing feature when mated :
 - External : IPx9K, IP67, 1000 mbars under air pressure
 - Internal : individual cavity sealing with SWS*
- IP2X B electrical shock protection

Physical features

- Plastic parts: PBT
- Shielding plates: Copper Alloy Tin-plated

Typical applications

- High voltage DC connections for batteries, junction boxes, inverters, Power Electronic Boxes (PEB) and others

*SWS Single Wire Seal



Technical characteristics

Voltage		400 - 750 V
Max. current carrying capacity	Wire section 35 mm ²	185 A at 70°C
	Wire section 50 mm ²	230 A at 70°C
Sealing protection		IP67 & IPx9K
Electrical shock protection		IP2XB
Temperature range		-40°C to + 125 °C
Terminal insertion force	RCS800	30 N max.
	DCS-2 1.5 mm (Interlock)	12 N max
Terminal retention force	RCS800	300 N min.
	DCS-2 1.5 mm (Interlock)	120 N min.
Connector mating force		< 60 N
Shielding performance	at 100 MHz	60 dB

Part Numbers : Code1

Gender	Housing P/N
Female/Plug (black slider)	F673110
Male/Header	F473110

Part Numbers : Code2

Gender	Housing P/N
Female/Plug (brown slider)	F773110
Male/Header	F573110

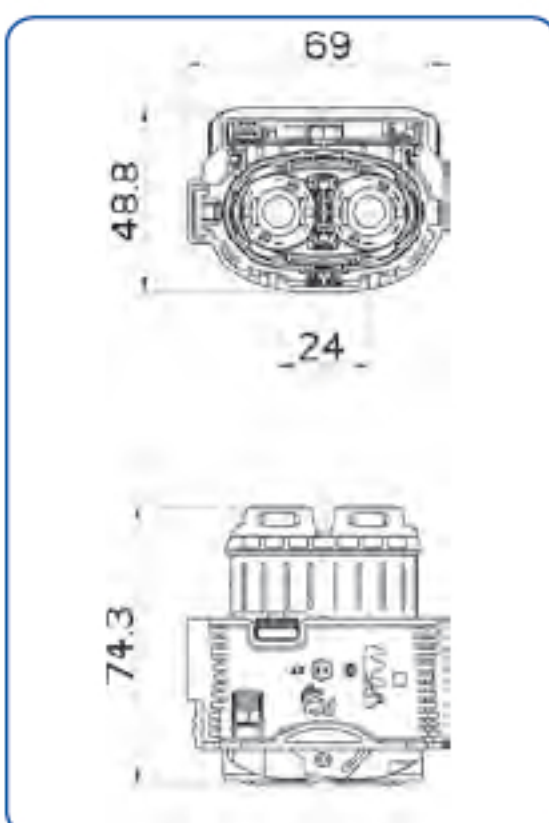

Female plug (code 1)

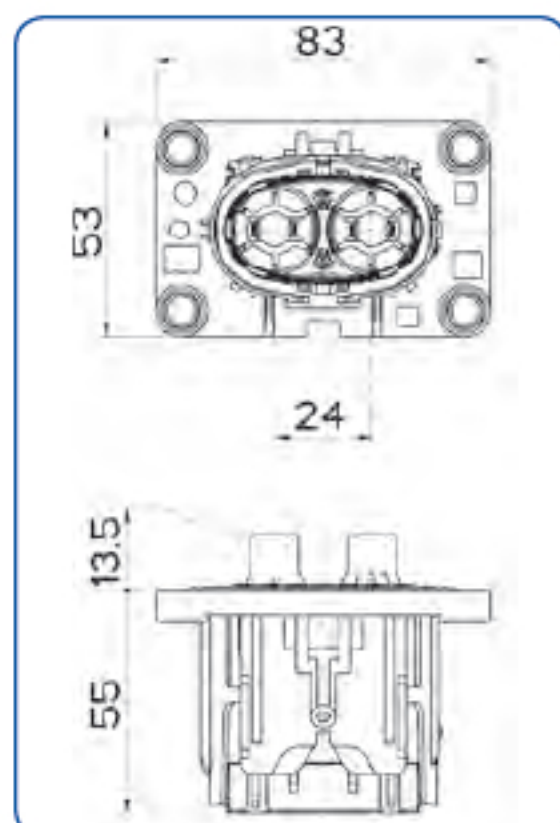

Male header (code 1)

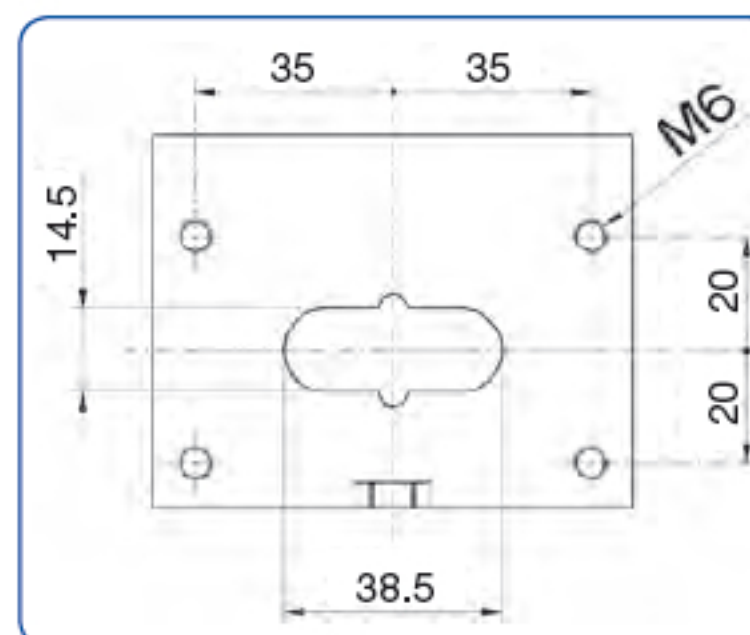

Header layout (code 1)

Dimensions en mm



EV/HEV