

Sep.1.2019 Copyright 2019 HIROSE ELECTRIC CO., LTD. All Rights Reserved.
In case of consideration for using Automotive equipment / device which demand high reliability, kindly contact our sales window correspondents.

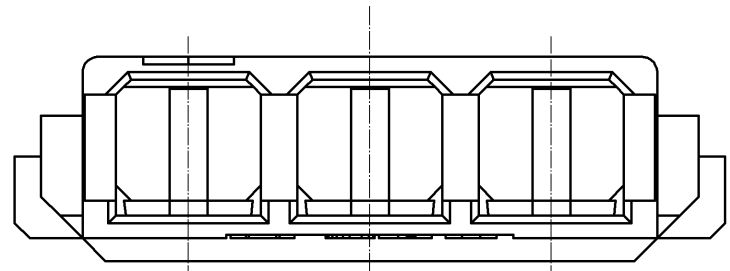
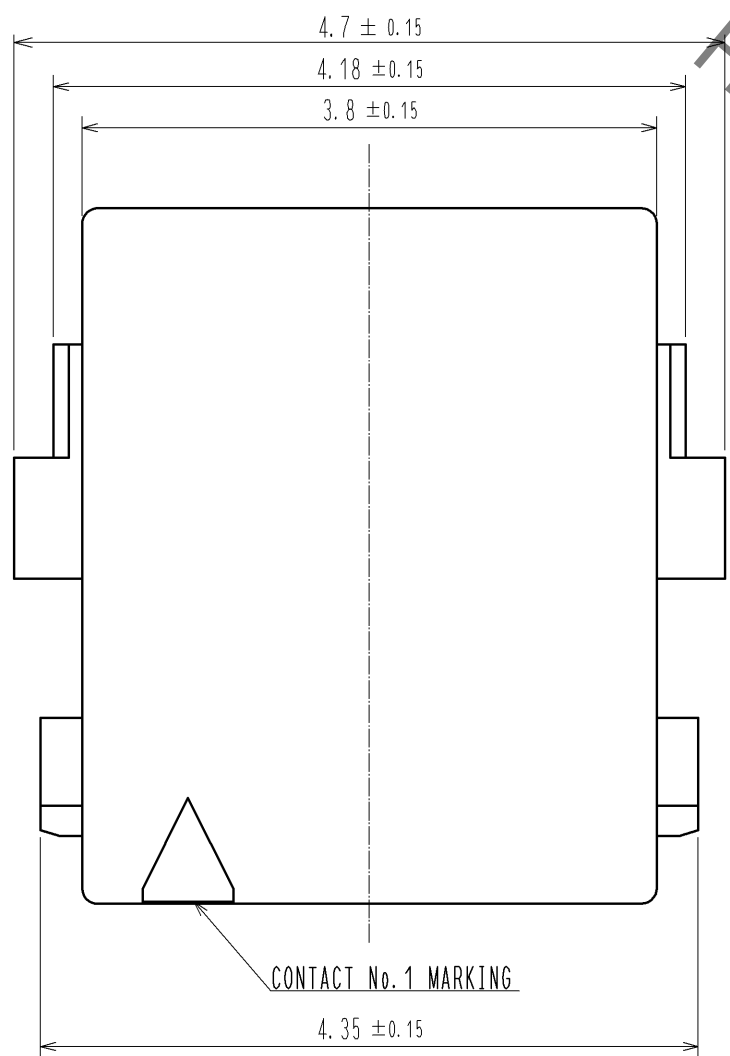
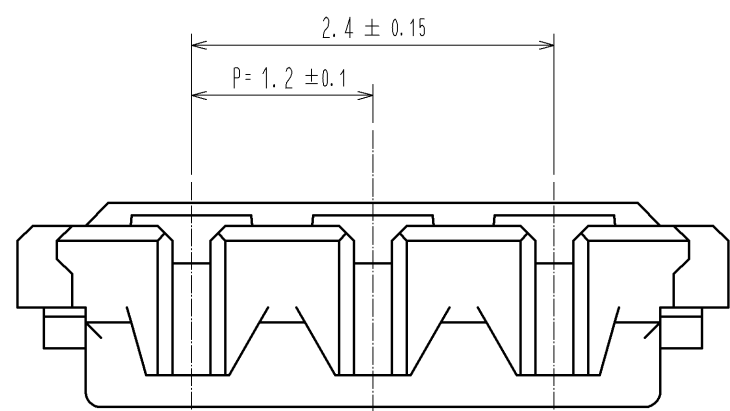

1) FIGURE OF INSERTION

HORIZONTALLY ○

DF57H-3S-1.2C

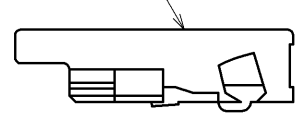

DIAGONAL ×

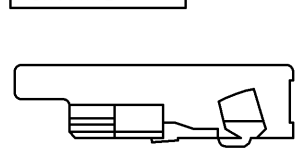

DF57-***SCF

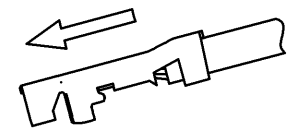
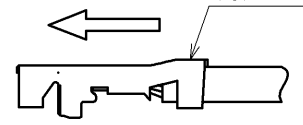

HRS DRAWING FOR REFERENCE

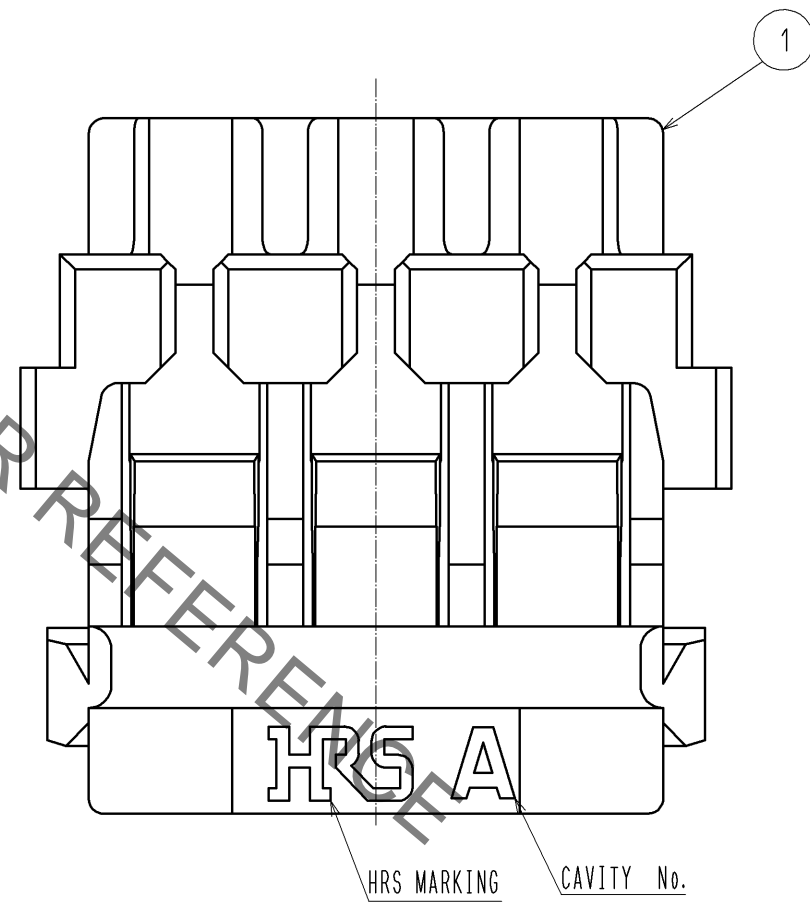
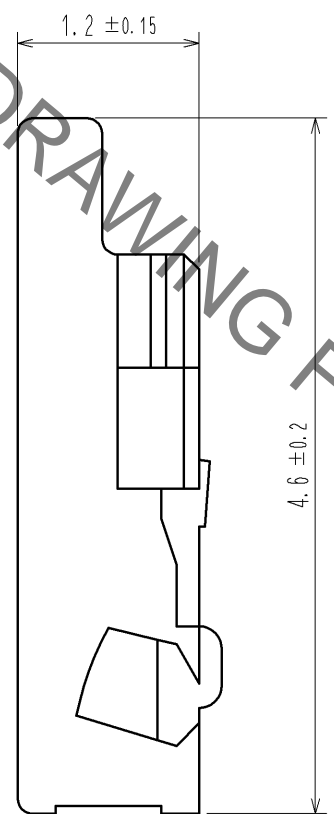

NOTE 1) AVOID ANGLED INSERTION OF CRIMP CONTACT(DF57-***SCF) TO MAINTAIN PERFORMANCE RELIABILITY.

NO.	MATERIAL	FINISH . REMARKS	NO.	MATERIAL	FINISH . REMARKS		
1	PBT			UL94V-0. NATURAL(WHITE)			
UNITS	mm	SCALE	COUNT	DESCRIPTION OF REVISIONS	DESIGNED	CHECKED	DATE
		20 : 1	△				
APPROVED : KI. AKIYAMA			12.02.21	DRAWING NO. EDC3-332438-01			
CHECKED : HK. UMEHARA			12.02.21	PART NO. DF57H-3S-1.2C			
DESIGNED : TS. KUMAZAWA			12.02.20	CODE NO. CL666-0012-0-00			
DRAWN : TS. KUMAZAWA			12.02.20	△ 1/2			

DF57 Series Mating / Unmating Operation Instruction (For DF57 series)

Mating

① By positioning the convexity of the socket sides to the header concavity, align the centers of the socket and the header in pitch direction.

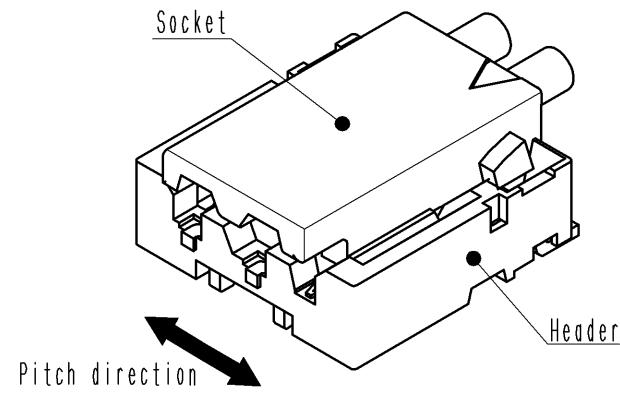

② Slightly press the socket down at cable side to tilted angle.

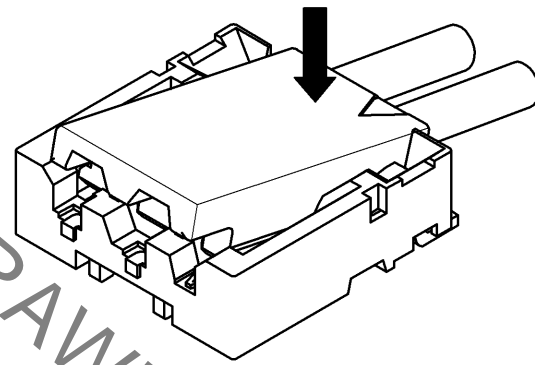

③ Press down at the lever side with stabilizing the cable side to insert. Mating completes.

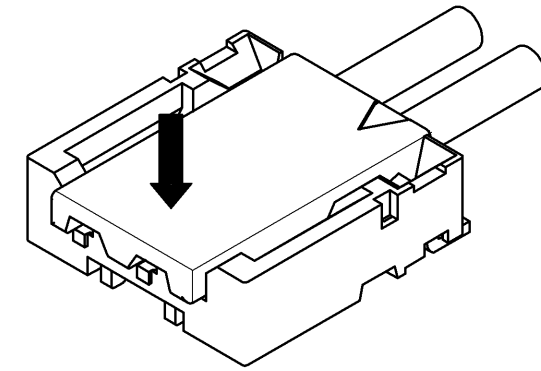

Unmating

① Hook the lever with finger nail.

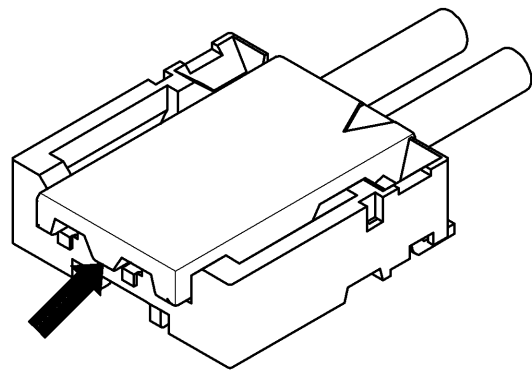

② Lift up to the upper direction and friction lock is released.

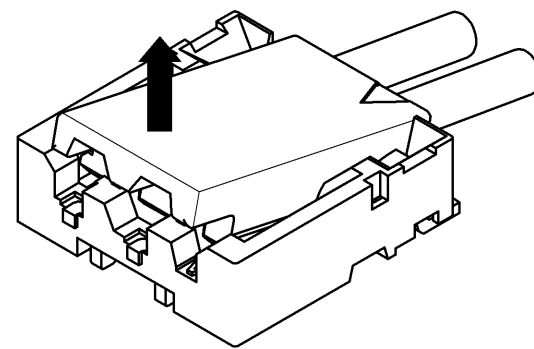

③ Lift up to the upper direction and positive lock is released. Removal completes.

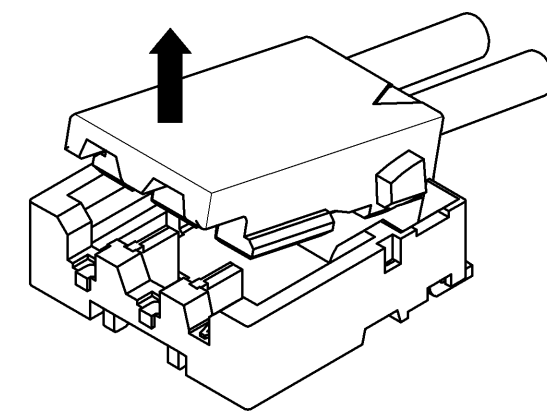

HRS DRAWING FOR REFERENCE

HRS	DRAWING NO.	EDC3-332438-01	△ 2/2
	PART NO.	DF57H-3S-1.2C	
	CODE NO.	CL666-0012-0-00	

Sep.1.2019 Copyright 2019 HIROSE ELECTRIC CO., LTD. All Rights Reserved. In case of consideration for using Automotive equipment / device which demand high reliability, kindly contact our sales window correspondents.