

DRAWING FOR REFERENCE: This is subject to change without notice
05/31/2013

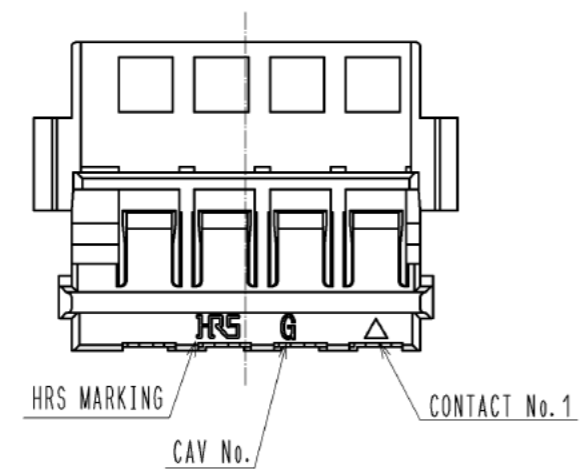

NOTE1. PER PACK : 100 PIECES
 2. REFER TO THE DF59 SERIES MATING/UNMATING OPERATION INSTRUCTION MANUAL(ETAD-H0496) FOR THE OPERATING OF THE PRODUCT.
 ⚠ 3. UL(FILE NO. E52653), C-UL(FILE NO. E52653) APPROVED PRODUCT.

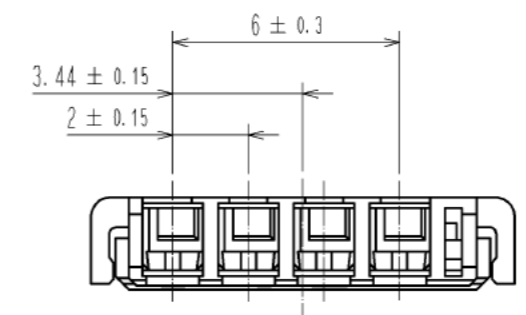
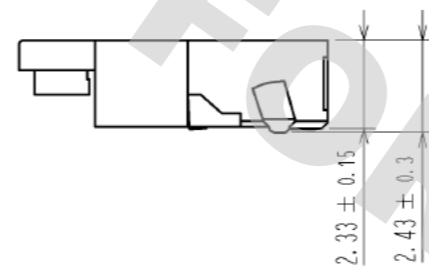
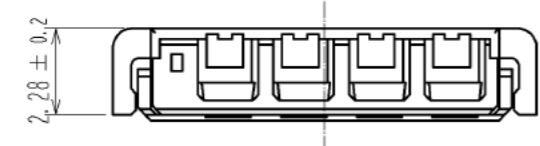
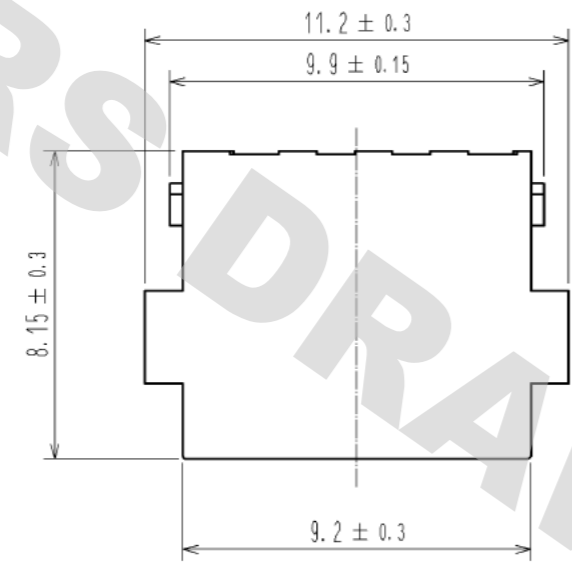

NO.	MATERIAL	FINISH . REMARKS	NO.	MATERIAL	FINISH . REMARKS		
			1	PBT	UL94V-0. NATURAL(WHITE)		
UNITS mm		SCALE 5 : 1	COUNT 1	DESCRIPTION OF REVISIONS DIS-H-006828	DESIGNED MI. SAKIMURA	CHECKED HK. UMEHARA	DATE 12. 04. 20
HRS HIROSE ELECTRIC CO., LTD.		APPROVED : KI. AKIYAMA	11. 03. 25	DRAWING NO. EDC3-331128-01			
		CHECKED : OM. MIYAMOTO	11. 03. 25	PART NO. DF59-4P-2C			
		DESIGNED : KT. ISHII	11. 03. 25	CODE NO. CL667-0013-0-00			
		DRAWN : KT. ISHII	11. 03. 25				1/2

Operation Procedures for Crimp Socket

【 Mating 】

1. By positioning the convexity of the crimp socket sides to the receptacle concavity, align the centers of the crimp socket and the receptacle in pitch direction.

2. Keep pressing down at the cable side and also apply force to the lever side to mate.
(If the cable side floats before mating is finished, the lock may not work.)

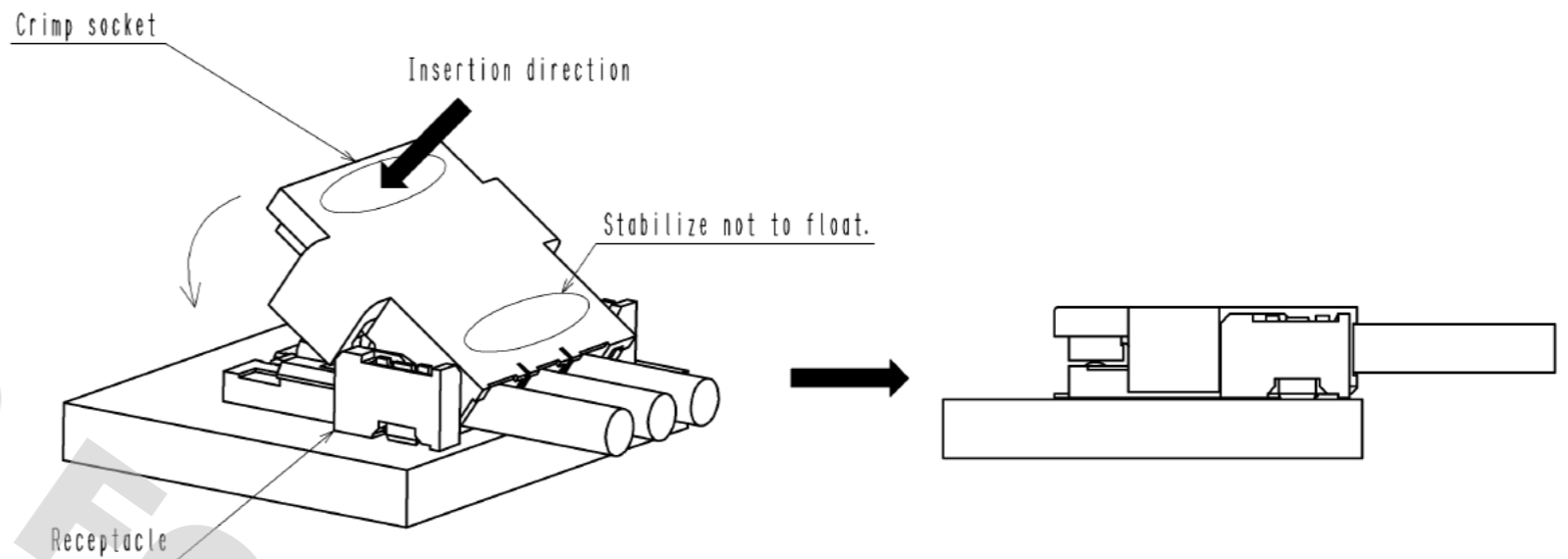
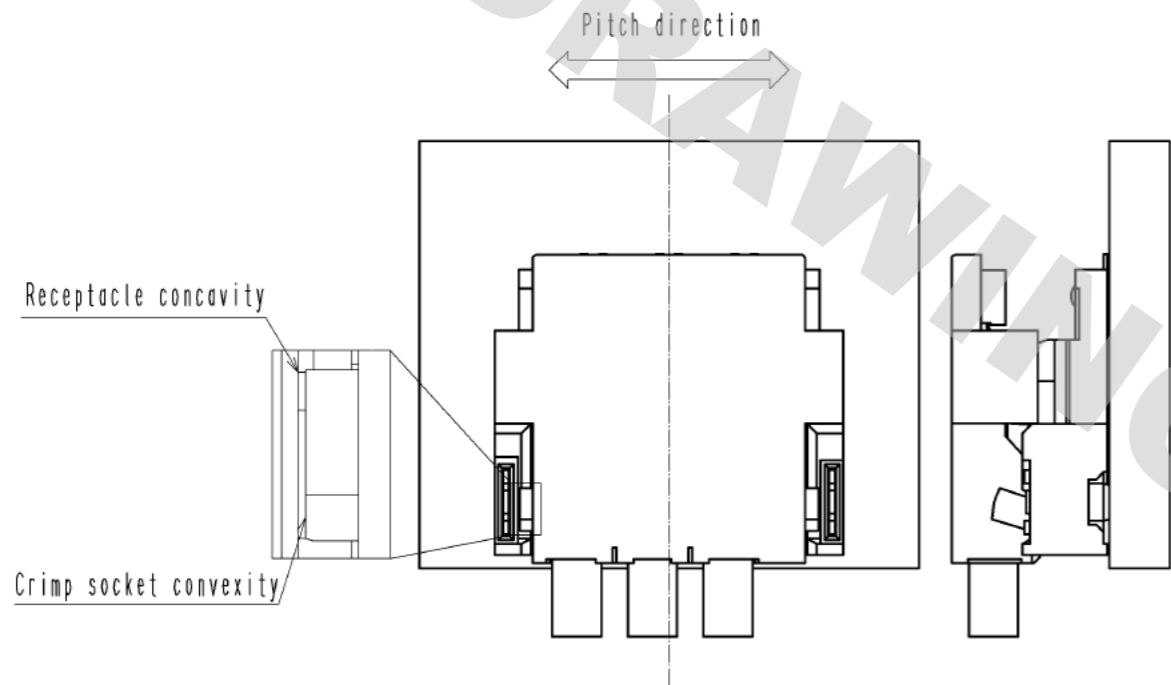

【 Unmating 】

1. Hook the lever with finger and lift up to the upper direction for unlock.
Note) When lifting up the lever, do not apply downward force to the cable side of the crimp socket. This could damage the connector.

Make sure to use the lever for removal operation.
If the cable is pull for removal, it could break the cable or damage the connector.

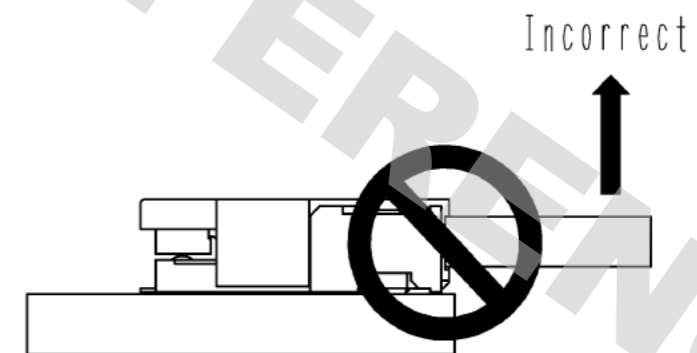
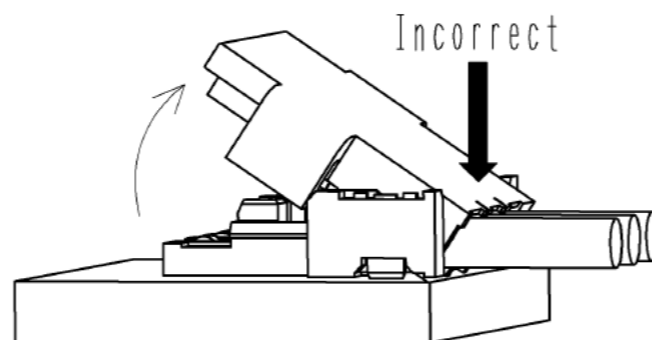
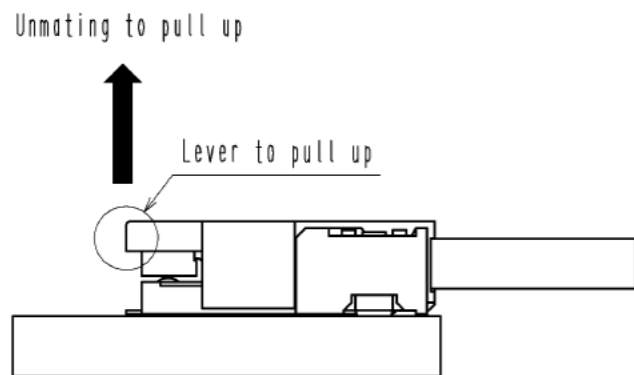

HRS

図番: EDC3-331128-01
製品名: DF59-4P-2C
製品コード: CL667-0013-0-00

2/2