

PRODUCT NUMBER
91601-YXXZLF

WHEN NEEDED, SUFFIX LETTER "LF"
INDICATES THE PRODUCT IS RoHS
COMPATIBLE, SEE NOTE 6

OPTIONAL LETTER

A: PRODUCT WITH PICK UP CAP PACKED IN
TAPE & REEL SEE TA856.

NUMBER OF POSITIONS: 02 UP TO 25.
MORE THAN 25 POSITIONS ON SPECIAL REQUEST.

PLATING CODE

3= 0.76µm GOLD ON CONTACT AREA.
3.81µm TIN-LEAD ON TAIL.

4= 5µm TIN-LEAD ON CONTACT AREA.
3.81µm TIN-LEAD ON TAIL.

WHEN SUFFIX "LF" IS REQUIRED, 2µm MIN MATTE
TIN OVER 1.27 MIN Ni IS SUPPLIED INSTEAD OF SnPb.

NOTES:

- 1 - HOUSING & PICK UP CAP MAT'L: THERMOPLASTIC GLASS FILLED
FLAME RETARDANT PER UL 94 V-0 COLOR: GREY.
- 2 - TERMINAL MATERIAL: PHOSPHOR BRONZE.
- 3 - 2 UP TO 4 POSITIONS PRODUCT PACKED IN PLASTIC BOX.
5 UP TO 30 POSITIONS PRODUCT PACKED IN TUBE.
- 4 - TO DETERMINE DIMENSIONS:
N = NUMBER OF POSITIONS
EXAMPLE: 8 POS: $(N \times 2.54) - 0.08 = 20.24$ mm.
- 5 - RECOMMENDED IR PROFILE PER TA842.
- 6 - RoHS COMPATIBLE PRODUCT SPECIFICATIONS

a - PLATING:

- "LF" MEANS THE PRODUCT IS LEAD-FREE,
2µm MINIMUM MATTE TIN OVER 1.27µm
MINIMUM NICKEL UNDERPLATE.

b - MANUFACTURING PROCESS COMPATIBILITY

- THE HOUSING WILL WITHSTAND EXPOSURE TO
260°C PEAK TEMPERATURE FOR 30 SECONDS
MAX IN A CONVECTION, INFRA-RED OR VAPOR
PHASE OR REFLOW OVEN.

c - LABELING:

- MEETS PACKAGING SPECS AS PER GS-14-920

d - LEGAL STATEMENT: SEE GS-22-008

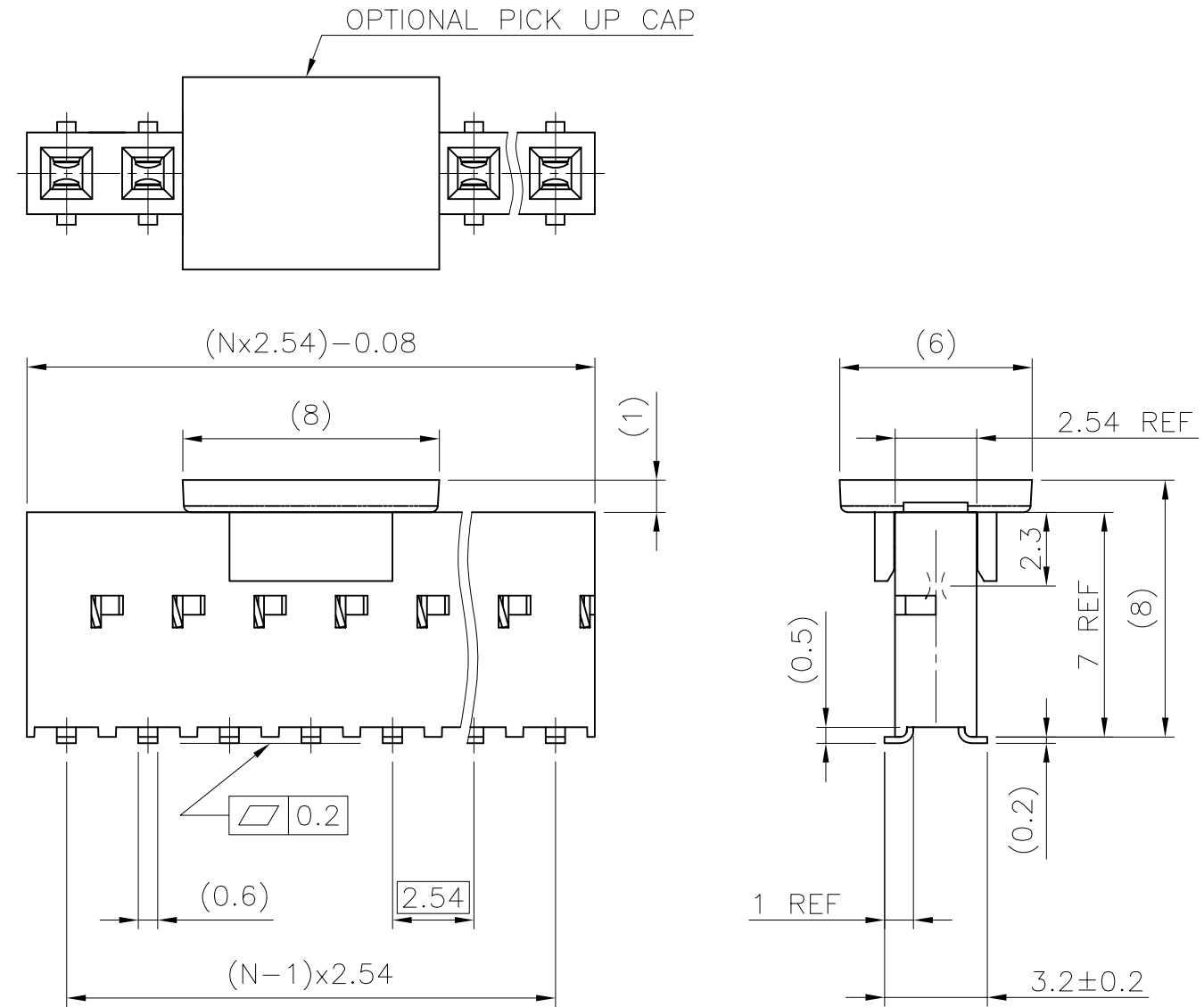

mat'l. code SEE NOTES				surface ISO 1302	tolerance ISO 406 ISO 101	projection mm	product family DUBOX
ltr	ecn no	dr	date	tolerances unless otherwise specified		mm	title BtB RECEPT VERT SR SMT
V	F03.0284	DLE	03.10.08	angles	.0±.3		
W	F04-0347	DLE	04.11.10	linear	.00±.0x	scale 5:1	sheet 1 of 2
X	F06-0204	DLE	06.06.23	0°±2°	.000±.00x		
Y	F06-0288	DLE	06.09.28	dr	D LEGRAND	96.10.11	size A3
AA	F07-0234	LMU	07.07.10	enr	P NIZZI	96.10.11	
				chr	D LE	96.10.11	type Product Customer Drawing
				appd	P NZ	96.10.11	
sheet index	revision sheet	AA	B				
		1	2				

1

2

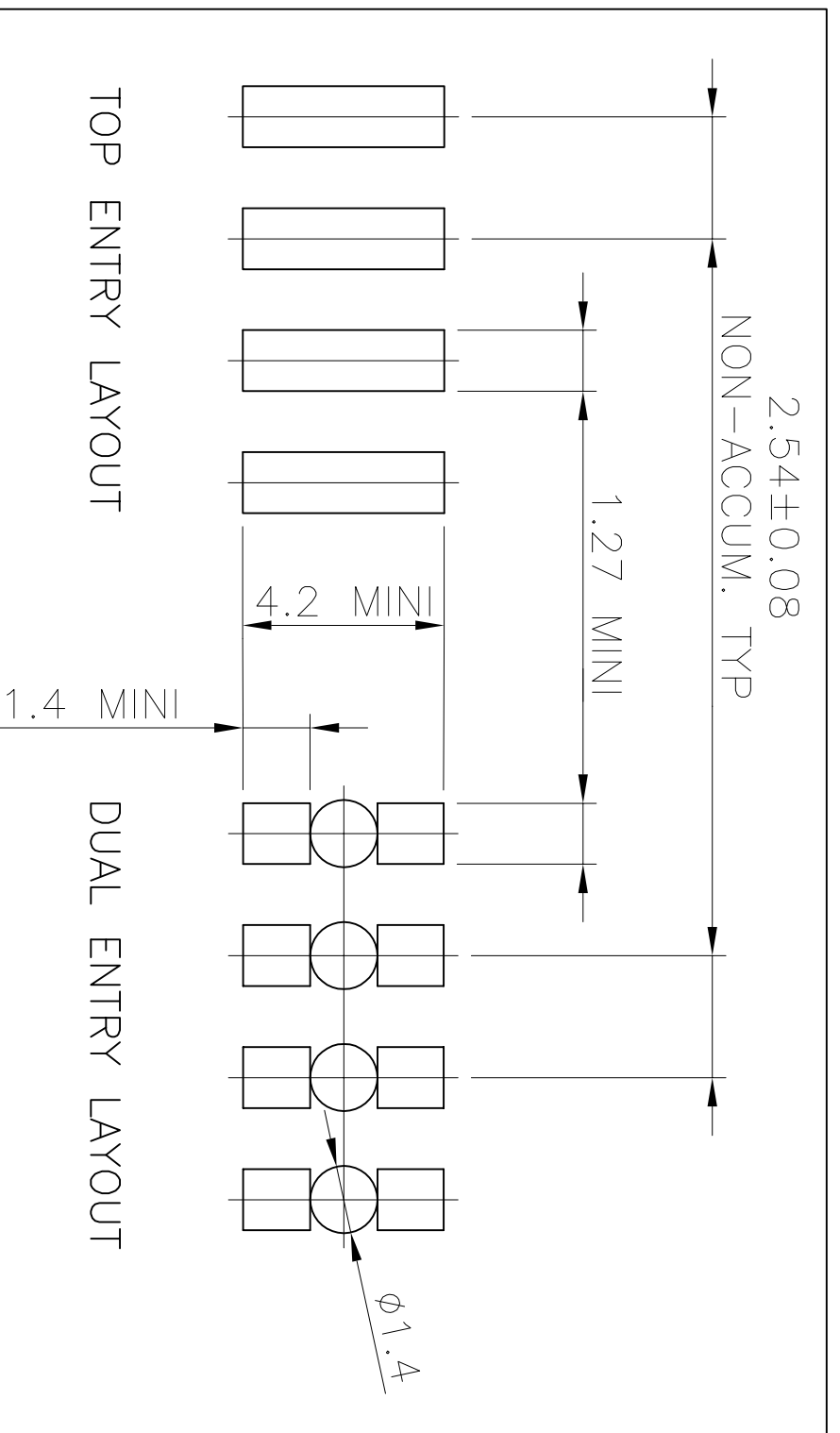

FCIconnect.com

Copyright FCI

mat'l. code		surface		tolerance		projection		product family	
SEE NOTES		ISO 1302		ISO 406 ISO 1101		 mm scale 1:1		DUBOX	
ltr	ecn no	dr	date	tolerances unless otherwise specified				title	
A	F04-0347	DLE	04.11.10	angles	.XX ±0.15			BtB RECEIPT.	
B	F06-0204	DLE	06.06.23	linear	±0.05			VERT SR SMT	
				dr	D LEGRAND	96.10.11		dwg no	
				engr	P NIZZI	96.10.11		91601	
				chr	D LE	96.10.11		sheet 2 of 2	
				appd	P NZ	96.10.11		size	
								A4	
sheet index	revision							type	
								Product Customer Drawing	

form: A4

1

2