

966292-1 ✓ ACTIVE

TE Internal #: 966292-1

Crimp Wire Pins, Tabs & Ferrules, Ferrule, 26 AWG Wire Size, .12 – .15 mm² Wire Size, 278 CMA Wire Size, .06 in [1.6 mm] Barrel Inside Diameter

[View on TE.com >](#)



Terminals & Splices > Crimp Wire Pins, Tabs & Ferrules

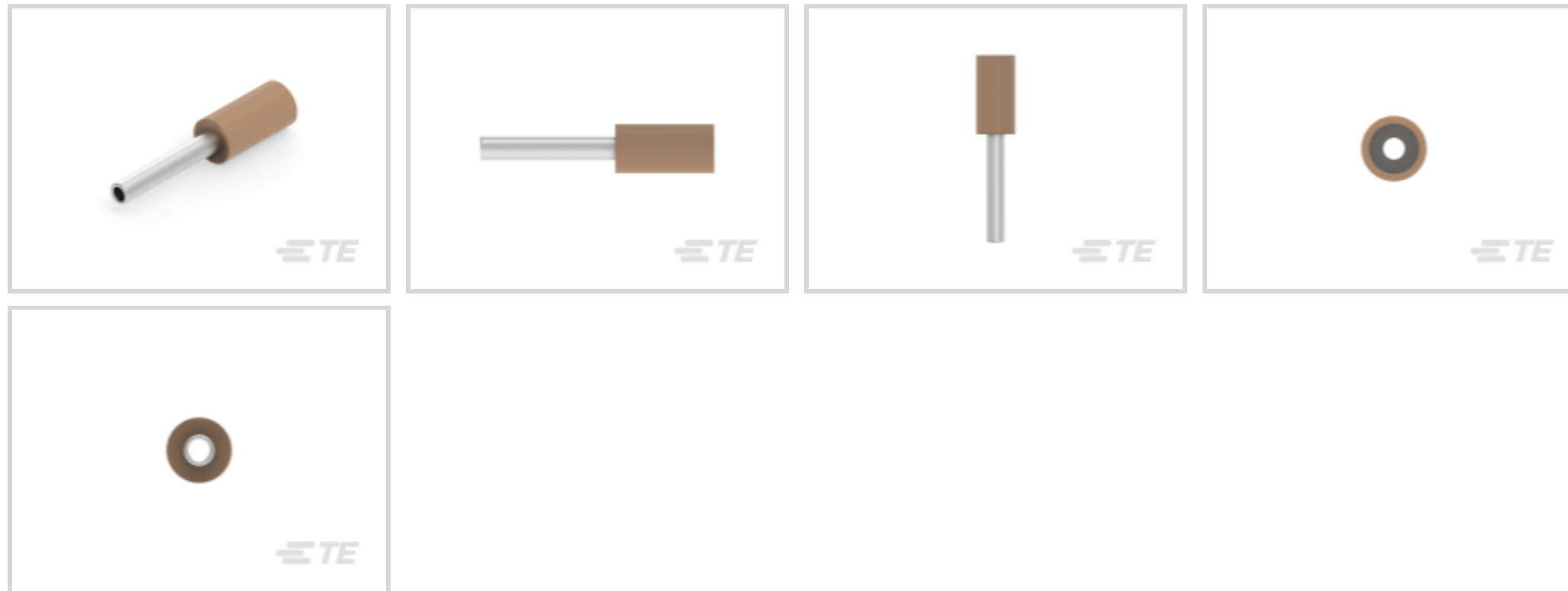

Crimp Wire Pin, Tab & Ferrule Terminal Type: **Ferrule**

Accepts Wire Insulation Diameter Range: **1.5 mm [.05 in]**

Wire Size: **278 CMA**

Features

Product Type Features

Sealable	No
Compatible With Discrete Wire Type	Stranded

Configuration Features

Compatible With Wire & Cable Type	Discrete Wire
-----------------------------------	---------------

Body Features

Double Wire	No
-------------	----

Contact Features

Terminal Length	6 mm [.234 in]
Crimp Wire Pin, Tab & Ferrule Terminal Type	Ferrule
Barrel Type	Closed
Terminal Plating Material	Tin
Terminal Orientation	Straight

Mechanical Attachment

Wire Insulation Support	Without
-------------------------	---------

Dimensions

--	--



2-Wire Size	26 AWG
Strip Length	8 mm[.315 in]
Accepts Wire Insulation Diameter Range	1.5 mm[.05 in]
Wire Size	278 CMA
Barrel Inside Diameter	1.6 mm[.06 in]
Terminal Material Thickness	.15 mm[.005 in]
Overall Product Length	10 mm[.4 in]

Usage Conditions

Insulation Option	Partially Insulated
Operating Temperature Range	105 °C[221 °F]

Operation/Application

Heavy Duty	No
------------	----

Packaging Features

Packaging Quantity	500
Packaging Method	Loose Piece

Other

Barrel Color	Brown
--------------	-------

Product Compliance

[For compliance documentation, visit the product page on TE.com>](#)

EU RoHS Directive 2011/65/EU	Compliant
EU ELV Directive 2000/53/EC	Compliant
China RoHS 2 Directive MIIT Order No 32, 2016	No Restricted Materials Above Threshold
EU REACH Regulation (EC) No. 1907/2006	Current ECHA Candidate List: JUNE 2022 (224) Candidate List Declared Against: JAN 2022 (223) SVHC > Threshold: Not Yet Reviewed
Halogen Content	Not Yet Reviewed for halogen content
Solder Process Capability	Not applicable for solder process capability

Product Compliance Disclaimer

This information is provided based on reasonable inquiry of our suppliers and represents our current actual knowledge based on the information they provided. This information is subject to change. The part numbers that TE has identified as EU RoHS compliant have a maximum concentration of 0.1% by weight in homogenous materials for lead, hexavalent

chromium, mercury, PBB, PBDE, DBP, BBP, DEHP, DIBP, and 0.01% for cadmium, or qualify for an exemption to these limits as defined in the Annexes of Directive 2011/65/EU (RoHS2). Finished electrical and electronic equipment products will be CE marked as required by Directive 2011/65/EU. Components may not be CE marked. Additionally, the part numbers that TE has identified as EU ELV compliant have a maximum concentration of 0.1% by weight in homogenous materials for lead, hexavalent chromium, and mercury, and 0.01% for cadmium, or qualify for an exemption to these limits as defined in the Annexes of Directive 2000/53/EC (ELV). Regarding the REACH Regulation, the information TE provides on SVHC in articles for this part number is based on the latest European Chemicals Agency (ECHA) 'Guidance on requirements for substances in articles' posted at this URL: <https://echa.europa.eu/guidance-documents/guidance-on-reach>

Compatible Parts

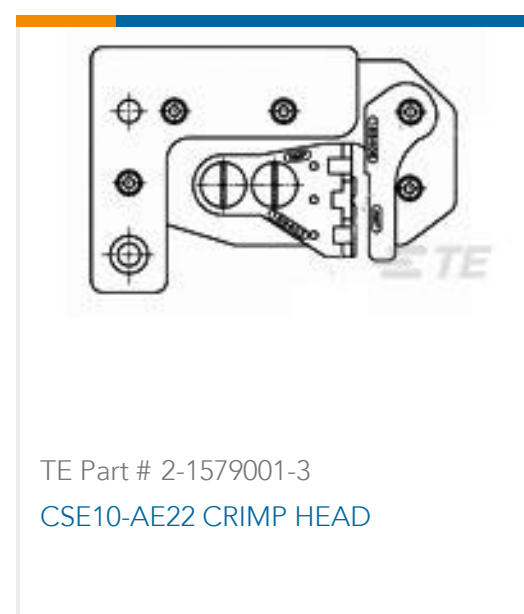
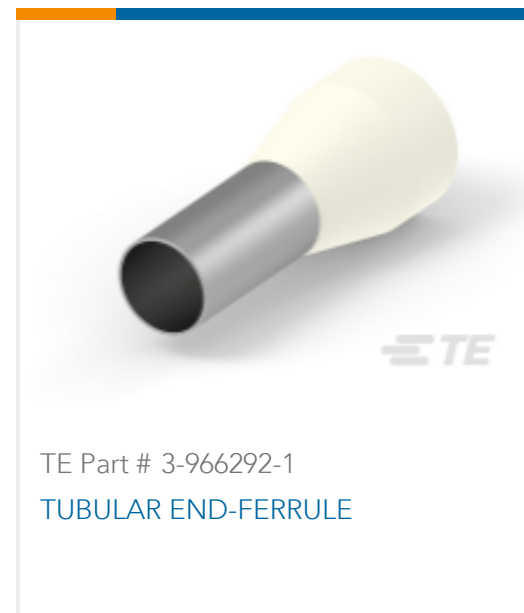

Customers Also Bought

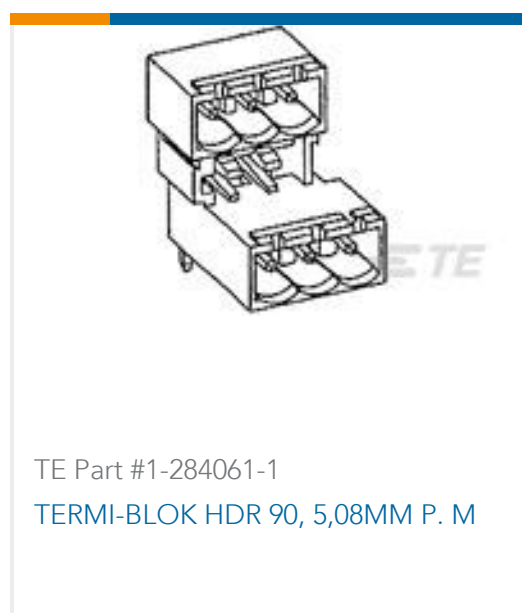



TE Part #216040-1
48P.IEC-F MALE CONN



TE Part #282909-6
TERMI-BLOK PCB MOUNT,5.08 MM 1



TE Part #6-147102-3
26 MODIV VRT DR 100/SFMNT 30AU



TE Part #827988-2
2X 2P MOD2 STIFTLI



TE Part #4-1879629-4
H4P 125R 0.05% 25PPM

Documents

Product Drawings

TUBULAR END-FERRULE

English

CAD Files

Customer View Model

[ENG_CVM_CVM_966292-1_O.3d_igs.zip](#)

English

Customer View Model

[ENG_CVM_966292-1_A1.3d_igs.zip](#)

English

Customer View Model

[ENG_CVM_966292-1_A1.3d_stp.zip](#)

English

3D PDF

English

Customer View Model

[ENG_CVM_966292-1_A1.2d_dxf.zip](#)

English

By downloading the CAD file I accept and agree to the [Terms and Conditions](#) of use.

Datasheets & Catalog Pages

Wire Ferrules

English

WIRE END FERRULES

English

