

PRODUCT NUMBER
91615-YXXZWLF

WHEN NEEDED, SUFFIX LETTER "LF"
INDICATES THE PRODUCT IS RoHS
COMPATIBLE, SEE NOTE 7

OPTIONAL LETTER SEE SHEET 2
N: PRODUCT WITH TYPE MARKING ON CONNECTOR

OPTIONAL LETTER

A: PRODUCT WITH PICK UP CAP PACKED IN
TAPE & REEL SEE TA856.

B: PRODUCT WITH PICK UP CAP PACKED IN TUBE.

NUMBER OF POSITIONS PER ROW: 03 UP TO 30.
MORE THAN 30 POSITIONS ON SPECIAL REQUEST.

PLATING CODE

3= 0.76µm GOLD ON CONTACT AREA.

3.81µm TIN-LEAD ON TAIL.

4= 5µm TIN-LEAD ON CONTACT AREA.

3.81µm TIN-LEAD ON TAIL.

WHEN SUFFIX "LF" IS REQUIRED, 2µm MIN MATTE
TIN OVER 1.27 MIN Ni IS SUPPLIED INSTEAD OF SnPb.

NOTES:

- 1 - HOUSING MAT'L: THERMOPLASTIC GLASS FILLED
FLAME RETARDANT PER UL 94 V-0 COLOR: GREY.
- 2 - TERMINAL MATERIAL: PHOSPHOR BRONZE.
- 3 - PACKAGING:
3 UP TO 4 POSITIONS PRODUCT PACKED IN PLASTIC BOX.
5 UP TO 30 POSITIONS PRODUCT PACKED IN TUBE.
WHOLE 91615-303B PRODUCT PACKED IN TUBE.
- 4 - TO DETERMINE DIMENSIONS:
N = NUMBER OF POSITIONS PER ROW
EXAMPLE: 8 POS: $((N+2) \times 2.54) - 0.08 = 25.32$ mm.
- 5 - RECOMMENDED IR PROFILE PER TA842.
- 6 - $\phi 2.65$ MINI FOR PICK & PLACE ASSEMBLY(=0 INSERTION FORCE).
- 7 - RoHS COMPATIBLE PRODUCT SPECIFICATIONS

a - PLATING:

- "LF" MEANS THE PRODUCT IS LEAD-FREE,
2µm MINIMUM MATTE TIN OVER 1.27µm
MINIMUM NICKEL UNDERPLATE.

b - MANUFACTURING PROCESS COMPATIBILITY

- THE HOUSING WILL WITHSTAND EXPOSURE TO
260°C PEAK TEMPERATURE FOR 30 SECONDS
MAX IN A CONVECTION, INFRA-RED OR VAPOR
PHASE OR REFLOW OVEN.

c - LABELING:

- MEETS PACKAGING SPECS AS PER GS-14-920

d - LEGAL STATEMENT: SEE GS-22-008

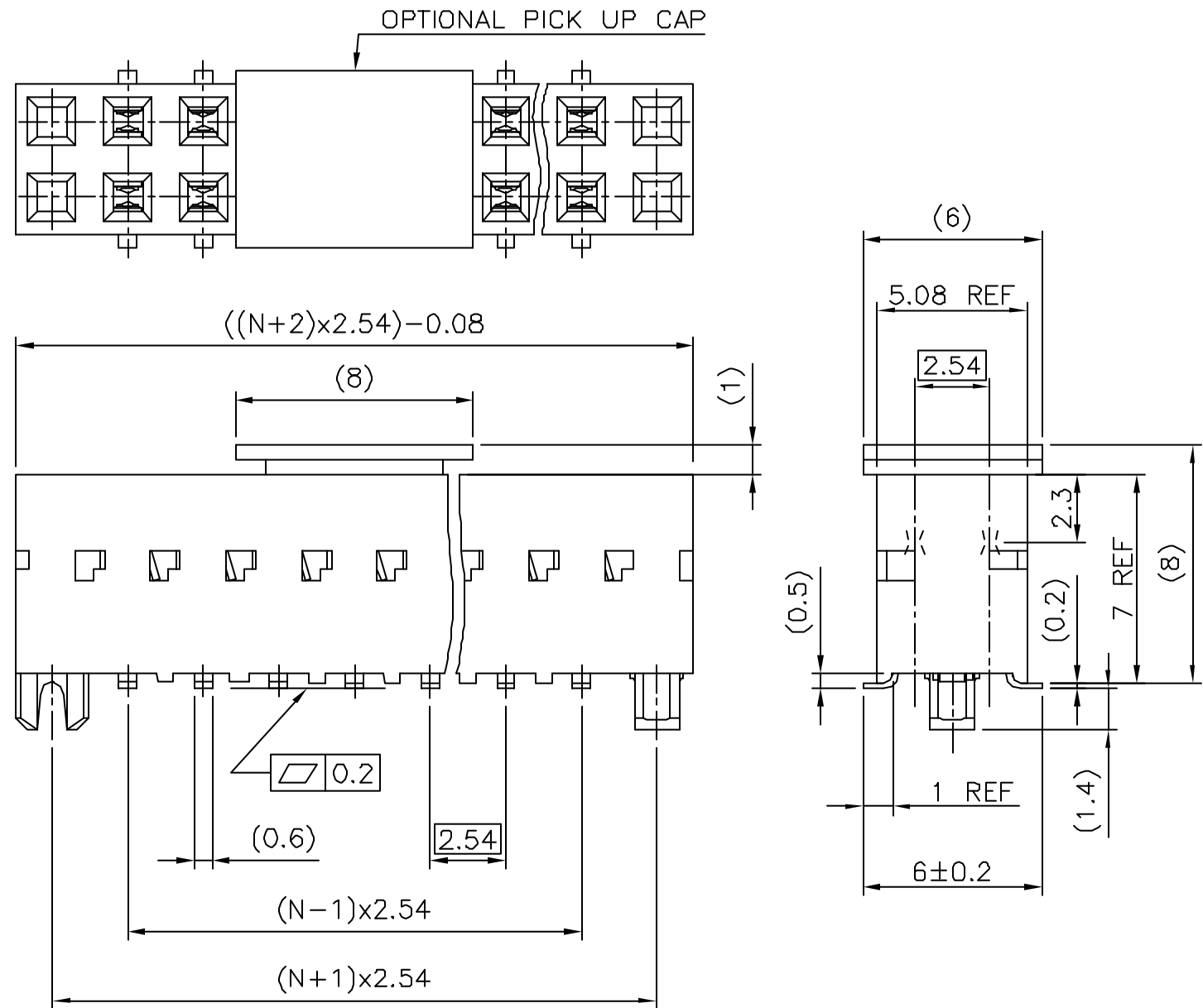

mat'l. code SEE NOTES				surface ISO 1302	tolerance ISO 406 ISO 1101	projection mm	product family DUBOX
ltr	ecn no	dr	date	tolerances unless otherwise specified		scale 5:1	title BtB RECEPT. VERT DR SMT
AB	04-0347	DLE	04.11.10	angles	±0.3		
AC	06-0137	DLE	06.02.27	Linear			
AD	06-0204	DLE	06.06.23	±2'			
				dr	P NIZZI	95.11.17	dwg no 91615 sheet 1 of 3 size A3
				enr	P.NZ	01.07.23	
				chr	P.NZ	01.07.23	
				appd	JF.N	01.07.23	
sheet index	revision sheet	AD 1	D 2	B 3			type CUSTOMER Drawing



Copyright FCI

PRODUCT NUMBER
91615-YXXZNLF

WHEN NEEDED, SUFFIX LETTER "LF"
INDICATES THE PRODUCT IS RoHS
COMPATIBLE, SEE NOTE 7

APPLICATION SPECIFIC

PRINTING METHOD FOR 91615-Y07 UP TO -Y50
MARKING: PART NUMBER AND DATE CODE

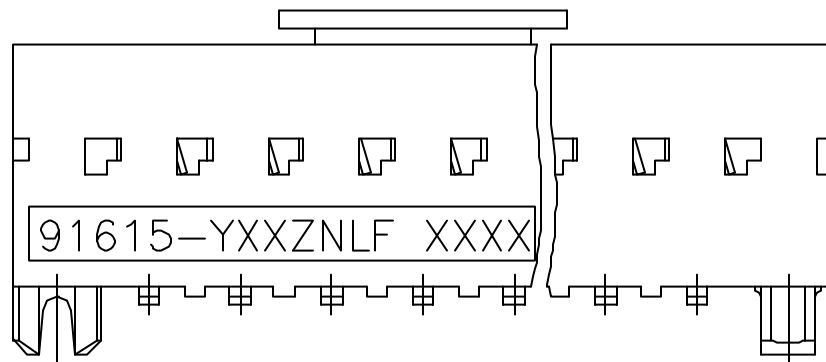

91615-YXXZNLF XXXX

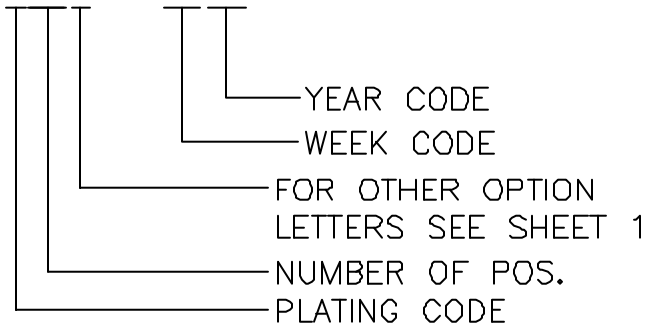

PRINTING METHOD FOR 91615-Y03 UP TO -Y07

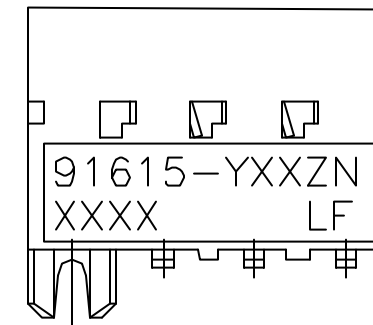

Copyright FCI

mat'l. code				surface ISO 1302 <input checked="" type="checkbox"/>		tolerance ISO 406 ISO 1101		projection 		product family DUBOX	
Ltr	ecn no	dr	date	tolerances unless otherwise specified		±0.3		mm		title BtB RECEPT. VERT DR SMT	
A	F10379	DLE	01.07.23	angles	Linear			scale N/A		dwg no 91615	
B	F04-0347	DLE	04.11.10	±2'						sheet 2 of - A3	
C	F06-0137	DLE	06.02.27							type CUSTOMER Drawing	
D	F06-0204	DLE	06.06.23	dr	D.LE	01.07.23					
				enr	P.NZ	01.07.23					
				chr	P.NZ	01.07.23					
				appd	JF.N	01.07.23					
sheet index	revision sheet										

1

2 3

4

5

6

A

B

C

D

A

B

C

D

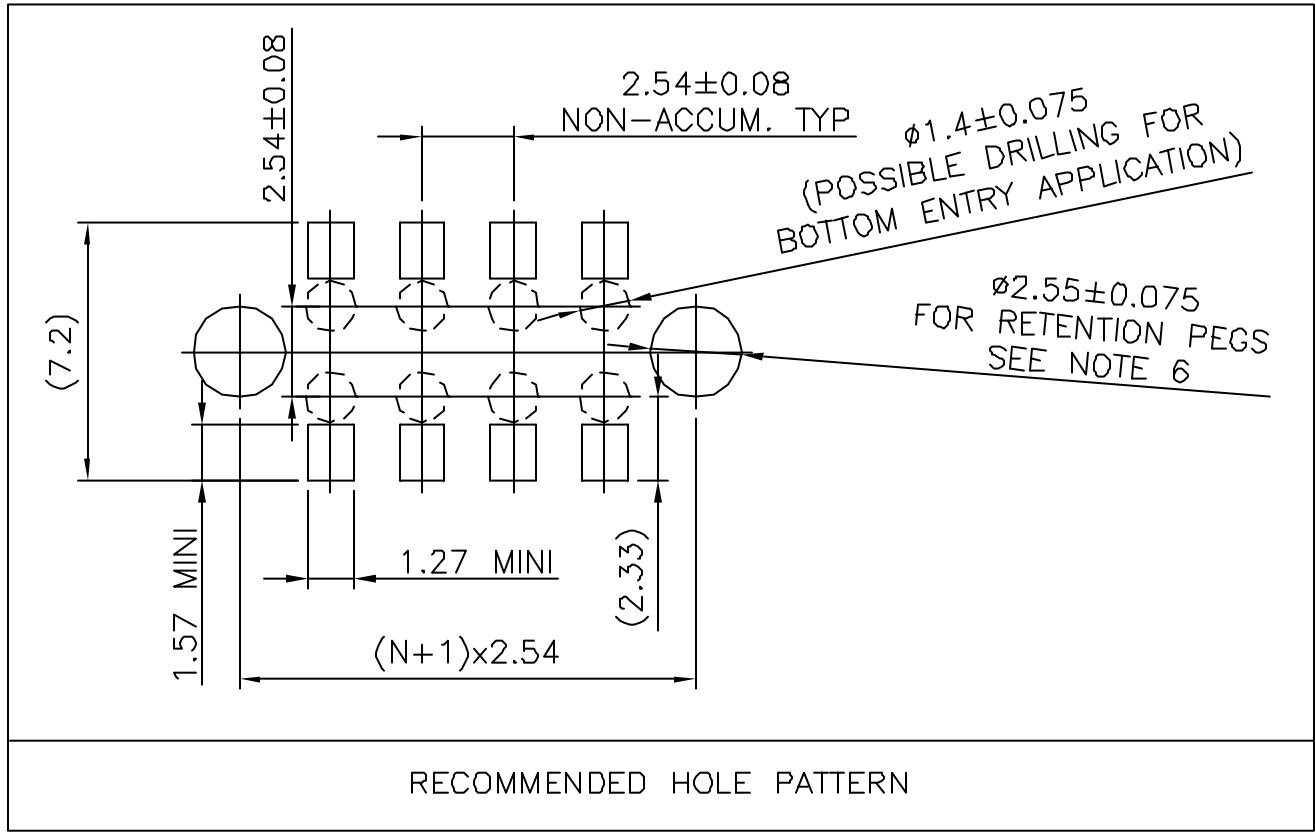

Copyright FCI

mat'l. code				surface ISO 1302 ✓		tolerance ISO 406 ISO 1101		projection 		product family DUBOX	
ltr	ecn no	dr	date	tolerances unless otherwise specified				mm		title BtB RECEPT. VERT DR SMT	
A	F04-0347	DLE	04.11.10	angles	Linear		±0.3		scale N/A		
B	F06-0204	DLE	06.06.23	±2°							
				dr	D.LE	04.11.10			dwg no		
				enr	P.NZ	04.11.10			sheet 3 of -		size
				chr	P.NZ	04.11.10			91615		A3
				appd	P.NZ	04.11.10			type		CUSTOMER Drawing
sheet index	revision sheet										