

REVISIONS					
REV	ECO	DESCRIPTION	DATE	BY	APPR
A1	-	RELEASE NUMBER	30/NOV/18	ROOKIE	TOMMY

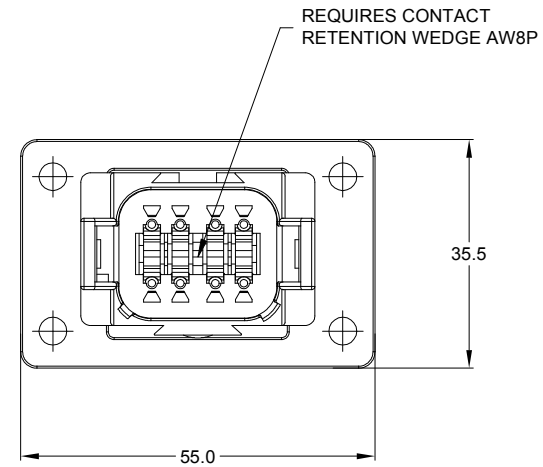

NOTES: UNLESS OTHERWISE SPECIFIED

1. SEE SHEET 2 FOR KEY ARRANGEMENTS AND COLORS.

2. MATERIAL:
HOUSING: THERMOPLASTIC
SEAL: SILICONE RUBBER

3. MODIFICATIONS: FLANGE

4. SPECIFICATIONS:
4.1 CURRENT RATING: 13 AMPS
4.2 OPERATING TEMPERATURE: -55°C TO +125°C.
4.3 DIELECTRIC WITHSTANDING VOLTAGE: LESS THAN 2 MILLIAMPS CURRENT LEAKAGE @ 1500 VOLTS AC.
4.4 INSULATION RESISTANCE: 1000 MEGOHMS MIN @ 25°C.
4.5 MOISTURE RESISTANCE: IP67 (MATED CONDITION)
4.6 MATING CYCLE DURABILITY: 100 CYCLES
4.7 RoHS COMPLIANT

5. MATING PART: AT06-08SX* PLUG.
(X=A,B,C,D KEYS, * = MODIFICATIONS AND COLORS)

6. ALL DIMENSIONS ARE FOR REFERENCE USE ONLY.

7. CONTACT SIZE AND REAR SEAL WIRE RANGE:

CONTACT SIZE	MIN. INSUL O.D.	MAX. INSUL O.D.	TYPICAL WIRE RANGE
16	2.24 mm (.088 in)	3.68 mm (.145 in)	14 - 20 AWG

SEE SHEET 2		DESCRIPTION		ITEM
QUANTITY	PART NUMBER	MATERIALS LIST		
<p>UNLESS OTHERWISE SPECIFIED</p> <p>1) All dimensions are in metric(mm). 2) Tolerances are as follows: 1 PL DEC ±0.30 Fractions ±1/64 2 PL DEC ±0.15 Angles ±1° 3 PL DEC ±0.08</p> <p>3) Note reference = </p>				
SIGNATURES		DATE		
DRAWN: ROOKIE		30/NOV/18		
CHECKED: ORION		30/NOV/18		
ENGINEER:				
APPROVAL: TOMMY		30/NOV/18		
MATERIAL SPECIFICATIONS:		CUSTOMER:		
PROCESS SPECIFICATIONS:		THIS DRAWING IS SUPPLIED FOR INFORMATION ONLY. DESIGN FEATURES, SPECIFICATIONS AND PERFORMANCE DATA SHOWN HEREON ARE THE PROPERTY OF THE AMPHENOL CORPORATION. NO RIGHTS OF REPRODUCTION ARE IMPLIED. ALL DIMENSIONS ARE SUBJECT TO NORMAL MANUFACTURING VARIATIONS.		
NEXT ASSY:		SCALE: NONE		
		<p>Amphenol</p> <p>Sine Systems - www.amphenol-sine.com 44724 Morley Drive Clinton Township, MI 48036</p>		<p>8P RECEPTACLE, FLANGE MOUNT</p>
SIZE	TYPE	DWG NO.	REVISION	
B	C-	AT04-08PX-L012	A1	
SHEET 1		OF 3		

TITLE: 8P RECEPTACLE FLANGE MOUNT DWG NO: AT04-08PX-L012 REV: A1 SH: 1 OF: 3

REVISIONS					
REV	ECO	DESCRIPTION	DATE	BY	APPR
A1	-	RELEASE NUMBER	30/NOV/18	ROOKIE	TOMMY

KEY A CONFLGURATION
STANDARD COLOR:GREY

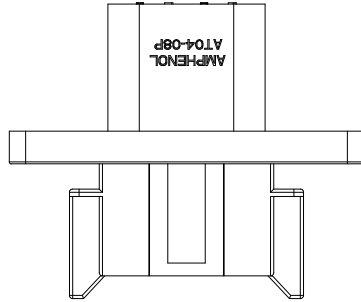

KEY B CONFLGURATION
STANDARD COLOR:BLACK

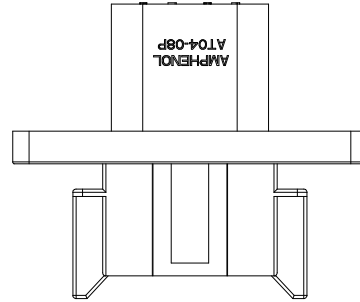

KEY C CONFLGURATION
STANDARD COLOR:GREEN

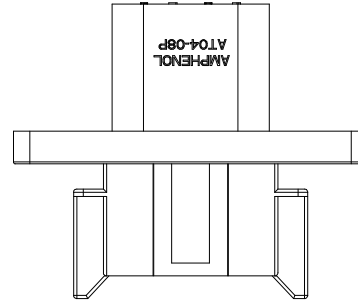

KEY D CONFLGURATION
STANDARD COLOR:BROWN

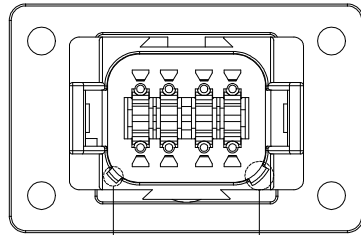
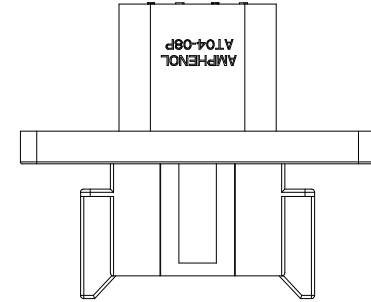

KEYWAY
(2)PLACES

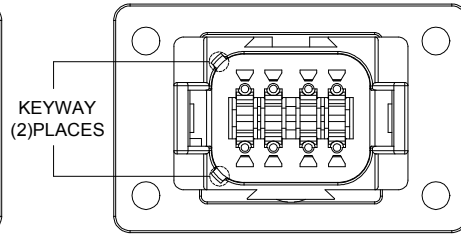

KEYWAY
(2)PLACES

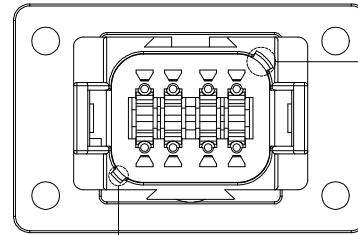

KEYWAY
(2)PLACES

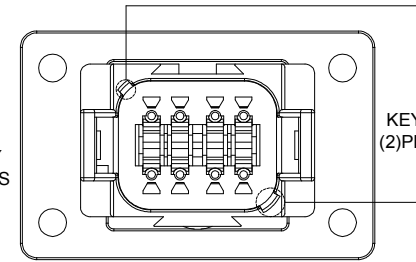

KEYWAY
(2)PLACES

KEY-A CONFIGURATION	
COLOR	PART NUMBER
GREY	AT04-08PA-L012

KEY-B CONFIGURATION	
COLOR	PART NUMBER
BLACK	AT04-08PB-L012

KEY-C CONFIGURATION	
COLOR	PART NUMBER
GREEN	AT04-08PC-L012

KEY-D CONFIGURATION	
COLOR	PART NUMBER
BROWN	AT04-08PD-L012

SEE SHEET 2		DESCRIPTION		ITEM
QUANTITY	PART NUMBER	MATERIALS LIST		
UNLESS OTHERWISE SPECIFIED: 1) All dimensions are in metric (mm). 2) Tolerances are as follows: 1 PL DEC ±0.30 Fractions ±1/64 2 PL DEC ±0.15 Angles ±1° 3 PL DEC ±0.08 3) Note reference =				
MATERIAL SPECIFICATIONS:		SIGNATURES DATE DRAWN: ROOKIE 30/NOV/18 CHECKED: ORION 30/NOV/18 ENGINEER: APPROVAL: TOMMY 30/NOV/18		
PROCESS SPECIFICATIONS:		Amphenol Sine Systems - www.amphenol-sine.com 44724 Morley Drive Clinton Township, MI 48036		
NEXT ASSY:		8 RECEPTACLE, FLANGE MOUNT THIS DRAWING IS SUPPLIED FOR INFORMATION ONLY. DESIGN FEATURES, SPECIFICATIONS AND PERFORMANCE DATA SHOWN HEREON ARE THE PROPERTY OF THE AMPHENOL CORPORATION. NO RIGHTS OF REPRODUCTION ARE IMPLIED. ALL DIMENSIONS ARE SUBJECT TO NORMAL MANUFACTURING VARIATIONS.		
		SIZE: B C- SCALE: NONE	DWG NO: AT04-08PX-L012	REVISION: A1
		SHEET 2 OF 3		

TITLE: 8P RECEPTACLE, FLANGE MOUNT DWG NO: AT04-08PX-L012 REV: A1 SH: 2 OF: 3

REVISIONS					
REV	ECO	DESCRIPTION	DATE	BY	APPR
A1	-	RELEASE NUMBER	30/NOV/18	ROOKIE	TOMMY

FOR REFERENCE ONLY

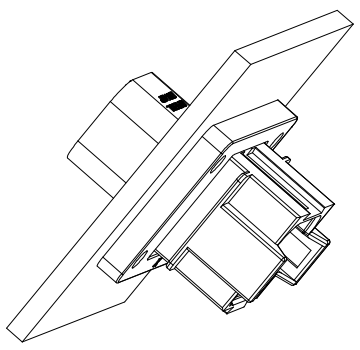

FRONT MOUNT

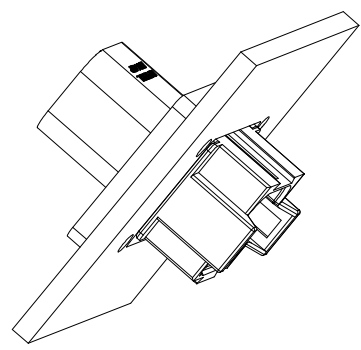

REAR MOUNT

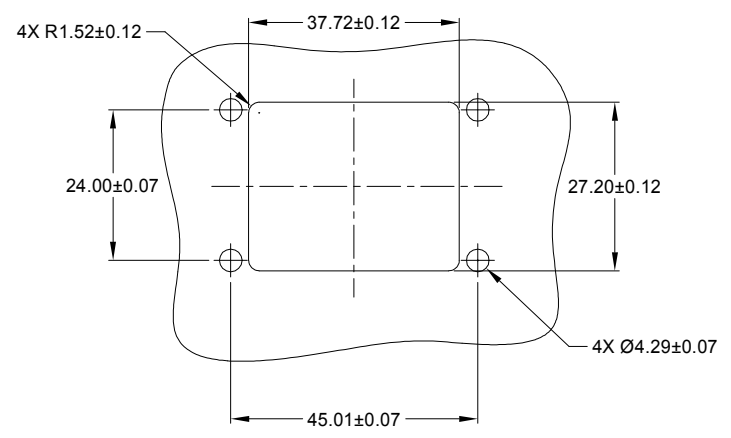

RECOMMENDED CUTOUT
FRONT AND REAR MOUNT

SEE SHEET 2				
PART NUMBER		DESCRIPTION		ITEM
QUANTITY				
MATERIALS LIST				
UNLESS OTHERWISE SPECIFIED 1) All dimensions are in metric(mm). 2) Tolerances are as follows: 1 PL DEC ±0.30 2 PL DEC ±0.15 3 PL DEC ±0.05 Fractions ±1/64 Angles ±1° 3) Note reference =				
SIGNATURES		DATE		
DRAWN: ROOKIE		30/NOV/18		
CHECKED: ORION		30/NOV/18		
ENGINEER:				
APPROVAL: TOMMY		30/NOV/18		
CUSTOMER:				
MATERIAL SPECIFICATIONS:				
PROCESS SPECIFICATIONS:		THIS DRAWING IS SUPPLIED FOR INFORMATION ONLY. DESIGN FEATURES, SPECIFICATIONS AND PERFORMANCE DATA SHOWN HEREON ARE THE PROPERTY OF THE AMPHENOL CORPORATION. NO RIGHTS OF REPRODUCTION ARE IMPLIED. ALL DIMENSIONS ARE SUBJECT TO NORMAL MANUFACTURING VARIATIONS.		
NEXT ASSY:				
SIZE		TYPE		DWG NO:
B C-				AT04-08PX-L012
SCALE: NONE		SHEET 3 OF 3		REVISION A1

TITLE: 8P RECEPTACLE FLANGE MOUNT, RD
 DWG NO: AT04-08PX-L012
 REV: A1
 SH: 3
 OF: 3