

10 9 8 7 6 5 4 3 2 1

PART NUMBER (SEE NOTE 5)	CKT. SIZE	DIM A	DIM B	DIM C
87381-06**	6	6.00	4.00	0.55
87381-08**	8	8.00	6.00	1.55
87381-10**	10	10.00	8.00	2.55
87381-12**	12	12.00	10.00	3.55
87381-14**	14	14.00	12.00	4.55
87381-16**	16	16.00	14.00	5.55
87381-18**	18	18.00	16.00	6.55
87381-20**	20	20.00	18.00	7.55
87381-22**	22	22.00	20.00	8.55
87381-24**	24	24.00	22.00	9.55
87381-26**	26	26.00	24.00	10.55
87381-28**	28	28.00	26.00	11.55
87381-30**	30	30.00	28.00	12.55
87381-32**	32	32.00	30.00	13.55
87381-34**	34	34.00	32.00	14.55
87381-36**	36	36.00	34.00	15.55
87381-38**	38	38.00	36.00	16.55
87381-40**	40	40.00	38.00	17.55
87381-42**	42	42.00	40.00	18.55
87381-44**	44	44.00	42.00	19.55
87381-46**	46	46.00	44.00	20.55
87381-48**	48	48.00	46.00	21.55
87381-50**	50	50.00	48.00	22.55

PART NO. LEGEND
FOR TUBE PACKAGING ONLY

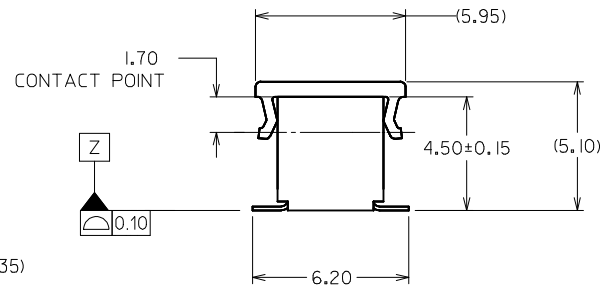
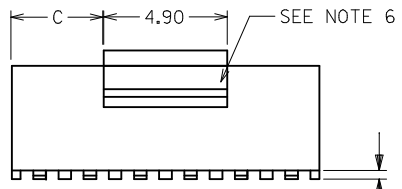
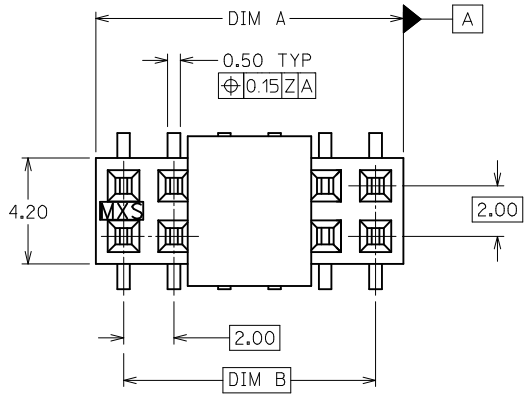
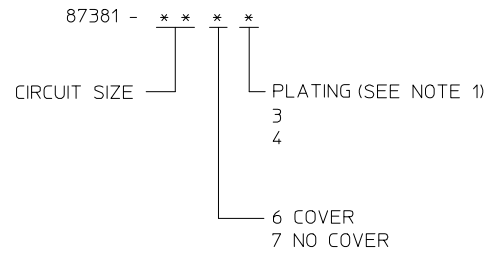

NOTES:

- PLATING FINISH:
3 - 0.76um MIN. GOLD IN CONTACT AREA 1.27um MIN. TIN
IN SOLDER TAIL AREA BOTH OVER 1.27um MIN. NICKEL OVERALL
4 - 0.38um MIN. GOLD IN CONTACT AREA 1.27um MIN. TIN
IN SOLDER TAIL AREA BOTH OVER 1.27um MIN. NICKEL OVERALL
- 12 CKT SIZE SHOWN FOR ASSY ILLUSTRATION ONLY. (SEE CHART FOR ALL PART SIZES), 6 CKT & 30 CKT ILLUSTRATED FOR TAPE/REEL VERSION ON SHT 2.
- PRODUCT SPECIFICATION PS-87380 APPLIES.
- COPLANARITY OF SOLDER TAILS ARE TO BE MEASURED BY RESTING THE PART ON A FLAT GAUGE SURFACE.
- TUBE PACKAGING STANDARD.
- COVER IS OPTIONAL, SEE LEGEND.
- PARTS SHALL BE PACKED IN MOISTURE BARRIER BAG.
- REFER SHT 3 FOR P/N: 87381-6000 T&R ILLUSTRATION.

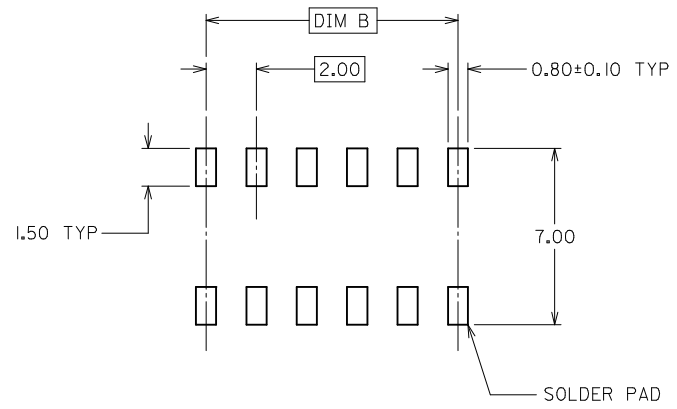

RECOMMENDED PCB LAYOUT

ADD P/N: 87381-3200	2009/04/07	QUALITY SYMBOLS
EC NO: S2009-0725	2009/04/07	▽=0
DRWN:SKANG	2009/04/06	∇=0
CHKD:ATSEE	2009/04/06	
APPR:MLONG	2009/04/07	
REV	DESCRIPTION	
8		

GENERAL TOLERANCES (UNLESS SPECIFIED)	mm	INCH
	4 PLACES ± ---	± ---
	3 PLACES ± ---	± ---
	2 PLACES ± 0.20	± ---
	1 PLACE ± ---	± ---
ANGULAR ± 3 °		
DRAFT WHERE APPLICABLE MUST REMAIN WITHIN DIMENSIONS		

DIMENSION STYLE MM ONLY	
DRAWN BY JAMES	DATE 1998/01/08
CHECKED BY LCHANG	DATE 1999/04/23
APPROVED BY SQUEK	DATE 1999/04/26
MATERIAL NO. SEE TABLE	
SIZE A3	

SCALE NTS	DESIGN UNITS METRIC	THIRD ANGLE PROJECTION
TITLE MGRID, TOP ENTRY RECEPT. 4.50MM HT., SMT		
MOLEX INCORPORATED		
DOCUMENT NO. SD-87381-**6*	SHEET NO. 1 OF 4	

9 8 7 6 5 4 3 2 1

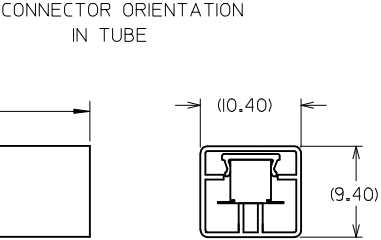
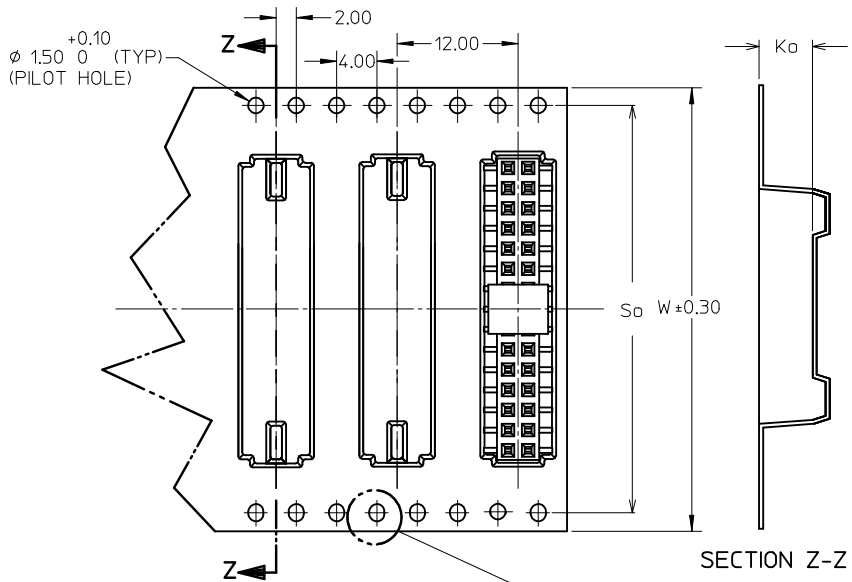

30 CKT FOR ILLUSTRATION ONLY
TAPE & REEL TYPE 'B'

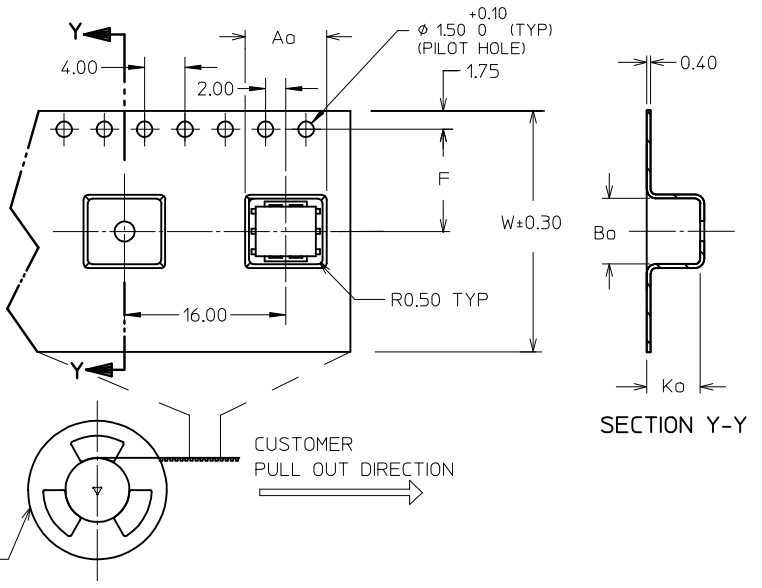
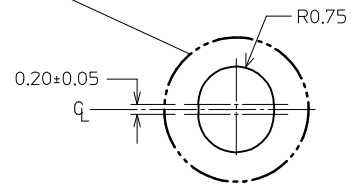

6 CKT FOR ILLUSTRATION ONLY
TAPE & REEL TYPE 'A'

NOTES:

- LEADER AND TRAILER TAPE
- PEELING OFF FORCE OF THE TOP TAPE: 20-80gf.
(PEELING DIRECTION AS SHOWN IN FOLLOWING FIGURE)
- PACKAGING STANDARD IS AS PER EIA-481.
- TAPE & REEL QUANTITY = SEE TABLE

ADD P/N: 87381-3200 EC NO: S2009-0725 DRWN:SKANG CHKD:ATSEE APPR:MLONG	2009/04/07	2009/04/06	2009/04/07
	2009/04/07	2009/04/06	2009/04/07
	2009/04/07	2009/04/06	2009/04/07
	2009/04/07	2009/04/06	2009/04/07

QUALITY SYMBOLS	▽=0
	∇=0
GENERAL TOLERANCES (UNLESS SPECIFIED)	mm
	INCH
	4 PLACES ± --- ± ---
	3 PLACES ± --- ± ---
	2 PLACES ± 0.20 ± ---
1 PLACE ± --- ± ---	
ANGULAR ± 3 °	
DRAFT WHERE APPLICABLE MUST REMAIN WITHIN DIMENSIONS	

DIMENSION STYLE		SCALE	DESIGN UNITS	THIRD ANGLE PROJECTION
MM ONLY		NTS	METRIC	
DRAWN BY	DATE	TITLE		
JAMES	1998/01/08	MGRID, TOP ENTRY RECEPT. 4.50MM HT., SMT		
CHECKED BY	DATE			
LCHANG	1999/04/23			
APPROVED BY	DATE			
SQUEK	1999/04/26			
MATERIAL NO.		DOCUMENT NO.		SHEET NO.
SEE TABLE		SD-87381-***6*		2 OF 4
SIZE	THIS DRAWING CONTAINS INFORMATION THAT IS PROPRIETARY TO MOLEX INCORPORATED AND SHOULD NOT BE USED WITHOUT WRITTEN PERMISSION			
A3				

DRAWN BY		DATE	TITLE	
JAMES		1998/01/08	MGRID, TOP ENTRY RECEPT. 4.50MM HT., SMT	
CHECKED BY		DATE		
LCHANG		1999/04/23		
APPROVED BY		DATE		
SQUEK		1999/04/26		
MATERIAL NO.		DOCUMENT NO.		SHEET NO.
SEE TABLE		SD-87381-***6*		2 OF 4
SIZE	THIS DRAWING CONTAINS INFORMATION THAT IS PROPRIETARY TO MOLEX INCORPORATED AND SHOULD NOT BE USED WITHOUT WRITTEN PERMISSION			
A3				

10 9 8 7 6 5 4 3 2 1

CKT SIZE	PART NO. WITH CAP IN TUBE	PART NO. WITH CAP IN TAPE / REEL	W	So	Ao	F	Bo	Ko	T&R TYPE (SHT 2)	T&R QTY PER REEL
6	87381-0664	87381-9002	24	-	7.00	11.50	6.50	5.30	A	500
8	87381-0864	87381-9003	24	-	7.00	11.50	8.50	5.30	A	600
10	87381-1064	87381-9005	24	-	7.00	11.50	10.50	5.30	A	680
14	87381-1464	87381-9006	32	28.40	7.20	14.20	14.50	5.30	B	750
16	87381-1664	87381-9004	32	28.40	7.20	14.20	16.50	5.30	B	800
18	87381-1864	87381-1800	32	28.40	7.20	14.20	18.50	5.30	B	750
20	87381-2063	87381-2000	32	28.40	7.20	14.20	20.50	5.30	B	800
22	87381-2264	87381-2200	44	40.40	7.20	20.20	22.50	5.30	B	500
30	87381-3064	87381-3000	44	40.40	7.20	20.20	30.50	5.30	B	500
32	87381-3264	87381-3200	44	40.40	7.20	20.20	32.50	5.30	B	500
44	87381-4464	87381-4400	56	52.40	7.20	26.20	44.50	5.30	B	500
46	87381-4664	87381-4600	72	68.40	7.20	34.20	46.50	5.30	B	750
50	87381-5063	87381-5030	72	68.40	7.20	34.20	50.50	5.30	B	500
50	87381-5064	87381-5000	72	68.40	7.20	34.20	50.50	5.30	B	500

ADD P/N: 87381-3200 EC NO: S2009-0725 DRWN:SKANG CHKD:ATSEE APPR:MLONG	2009/04/07 2009/04/06 2009/04/07	DESCRIPTION REV	QUALITY SYMBOLS	GENERAL TOLERANCES (UNLESS SPECIFIED)	DIMENSION STYLE	SCALE	DESIGN UNITS	THIRD ANGLE PROJECTION				
			$\nabla = 0$ $\sphericalcap = 0$	mm INCH 4 PLACES ± --- ± --- 3 PLACES ± --- ± --- 2 PLACES ± 0.20 ± --- 1 PLACE ± --- ± --- ANGULAR ± 3 °	MM ONLY	NTS	METRIC	DRAWN BY DATE JAMES 1998/01/08 CHECKED BY DATE LCHANG 1999/04/23 APPROVED BY DATE SQUEK 1999/04/26	TITLE	MATERIAL NO.	DOCUMENT NO.	SHEET NO.
				DRAFT WHERE APPLICABLE MUST REMAIN WITHIN DIMENSIONS	SEE TABLE	MOLEX INCORPORATED	SD-87381-***6*	3 OF 4				
				THIS DRAWING CONTAINS INFORMATION THAT IS PROPRIETARY TO MOLEX INCORPORATED AND SHOULD NOT BE USED WITHOUT WRITTEN PERMISSION								

9 8 7 6 5 4 3 2 1

CKT SIZE	PART NO. WITHOUT CAP IN TUBE	PART NO. WITHOUT CAP IN TAPE / REEL	W	So	Ao	F	Bo	Ko	T&R TYPE (SHT 2)	T&R QTY PER REEL
50	87381-5074	87381-6000 $\triangle/8$	72	68.40	6.80	34.20	50.50	8.00	B	500

$\triangle/8$ ILLUSTRATION FOR P/N: 87381-6000
50 CKT IN T&R W/O CAP

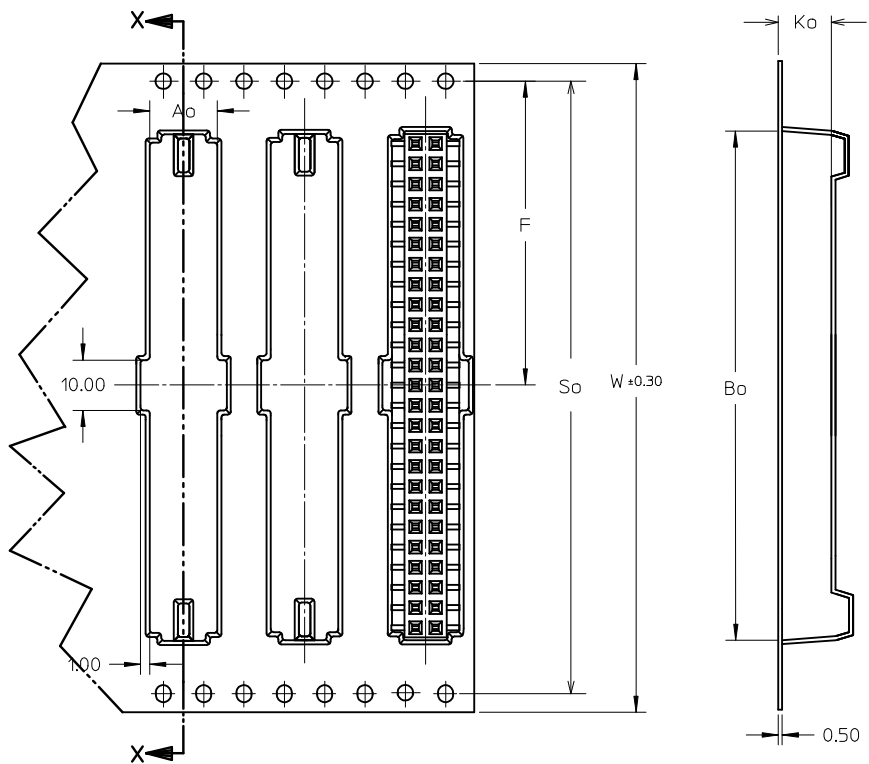

SECTION X-X

ADD P/N: 87381-3200 EC NO: S2009-0725 DRWN:SKANG 2009/04/07 CHKD:ATSEE 2009/04/06 APPR:MLONG 2009/04/07	QUALITY SYMBOLS $\blacktriangledown=0$ $\triangle=0$	GENERAL TOLERANCES (UNLESS SPECIFIED)		DIMENSION STYLE MM ONLY		SCALE NTS	DESIGN UNITS METRIC	THIRD ANGLE PROJECTION		
			mm	INCH	DRAWN BY JAMES	DATE 1998/01/08	TITLE MGRID, TOP ENTRY RECEPT. 4.50MM HT., SMT			
		4 PLACES	± ---	± ---	CHECKED BY LCHANG	DATE 1999/04/23	MOLEX INCORPORATED DOCUMENT NO. SD-87381-***6* SHEET NO. 4 OF 4			
		3 PLACES	± ---	± ---	APPROVED BY SQUEK	DATE 1999/04/26				
2 PLACES	± 0.20	± ---	ANGULAR ± 3 °		MATERIAL NO.		SEE TABLE			
1 PLACE	± ---	± ---	DRAFT WHERE APPLICABLE MUST REMAIN WITHIN DIMENSIONS		SIZE A3		THIS DRAWING CONTAINS INFORMATION THAT IS PROPRIETARY TO MOLEX INCORPORATED AND SHOULD NOT BE USED WITHOUT WRITTEN PERMISSION			