

LOC		DIST		REVISIONS			
P	LTR	DESCRIPTION	DATE	DWN	APPD		
A		REVISED PER 0G3B-1107-04	7/11/05	SS	DC		

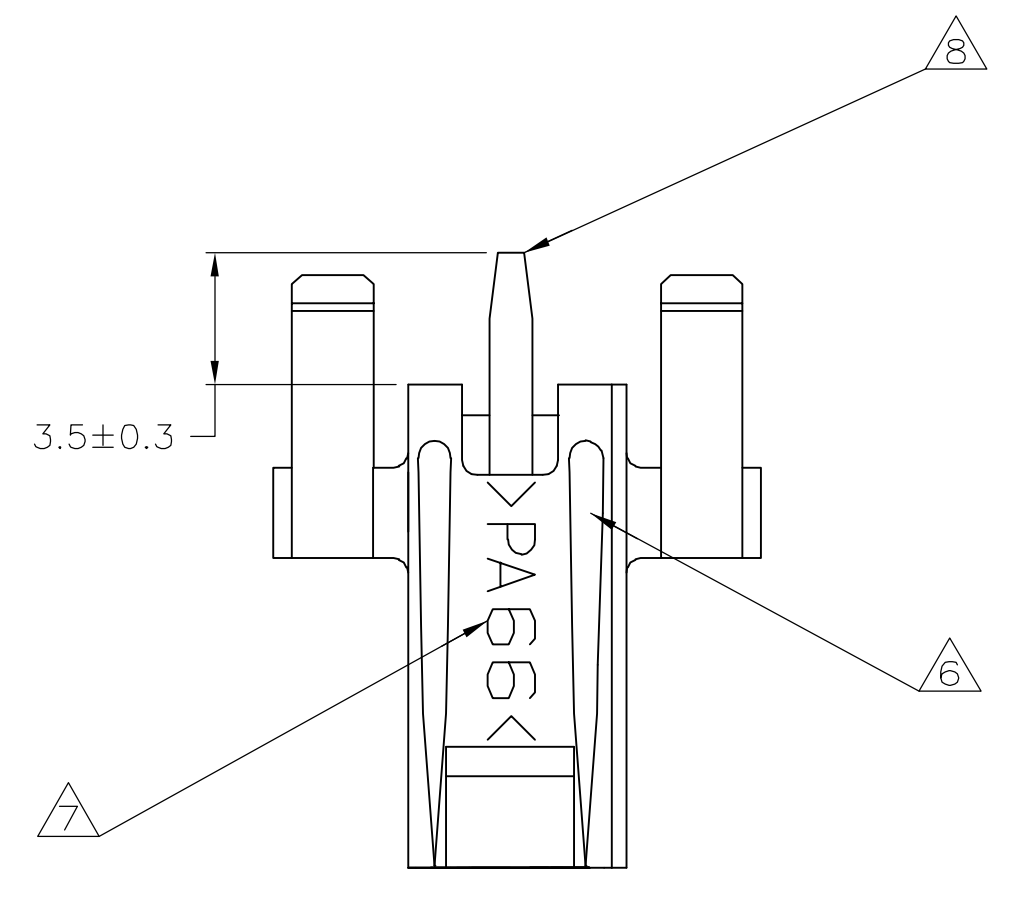

- 1 MATERIAL:
HOUSING: NYLON, UL94V-2 (COLOR - NATURAL, COLOR OF PARTS MAY VARY).
CONTACTS: 0.25 THK COPPER ALLOY.
- 2 CONTACT FINISH: 0.003 MIN THK TIN-LEAD OVER 0.00127 MIN THK NICKEL OVER ENTIRE CONTACT.
- 3 CONTACT FINISH: 0.00076 MIN THK GOLD PLATE ON PIN MATING SURFACE, 0.003 MIN THK TIN-LEAD PLATE ON SOLDER TAIL, ALL OVER 0.00127 MIN THK NICKEL BASE PLATE.
- 4 SOLDER TAIL MEETS AMP SOLDERABILITY SPECIFICATION 109-11-2.
- 5 MATES WITH SIMILARLY PLATED AMP-DUAC POWER CONNECTOR RECEPTACLE HOUSINGS/SOCKET CONTACTS.
- 6 RIBS ON FOUR CORNERS OPTIONAL.
- 7 AMP LOGO AND MATERIAL ID MAY BE LOCATED ON EITHER LONG SIDE OF PART.
- 8 SIZE, SHAPE OR STYLE OF THIS FEATURE MAY VARY.
- 9 CONTACT FINISH: 0.003 MIN THK TIN OVER 0.00127 MIN THK NICKEL OVER ENTIRE CONTACT.
- 10 CONTACT FINISH: 0.00076 MIN THK GOLD PLATE ON PIN MATING SURFACE, 0.003 MIN THK TIN PLATE ON SOLDER TAIL, ALL OVER 0.00127 MIN THK NICKEL BASE PLATE.

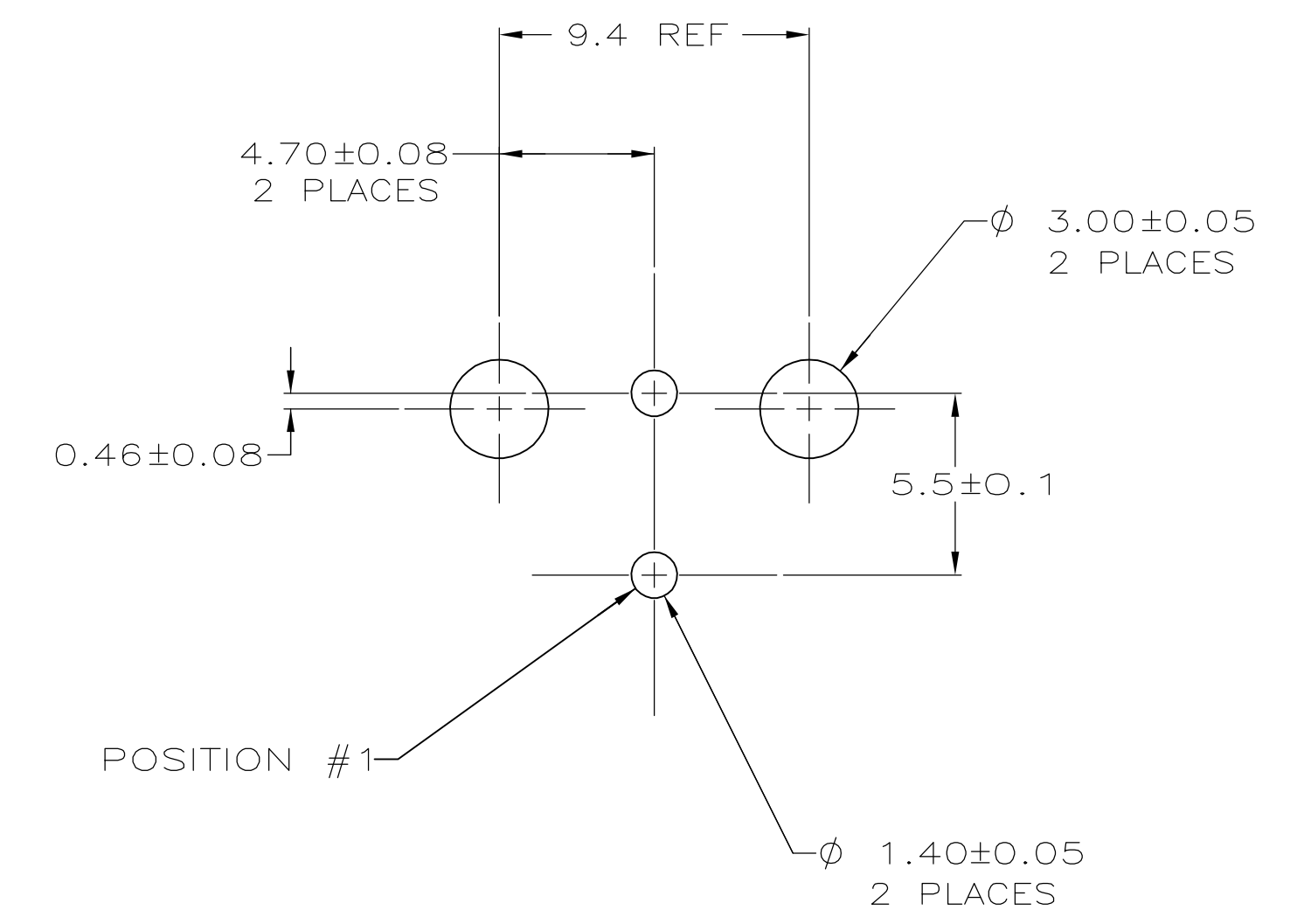
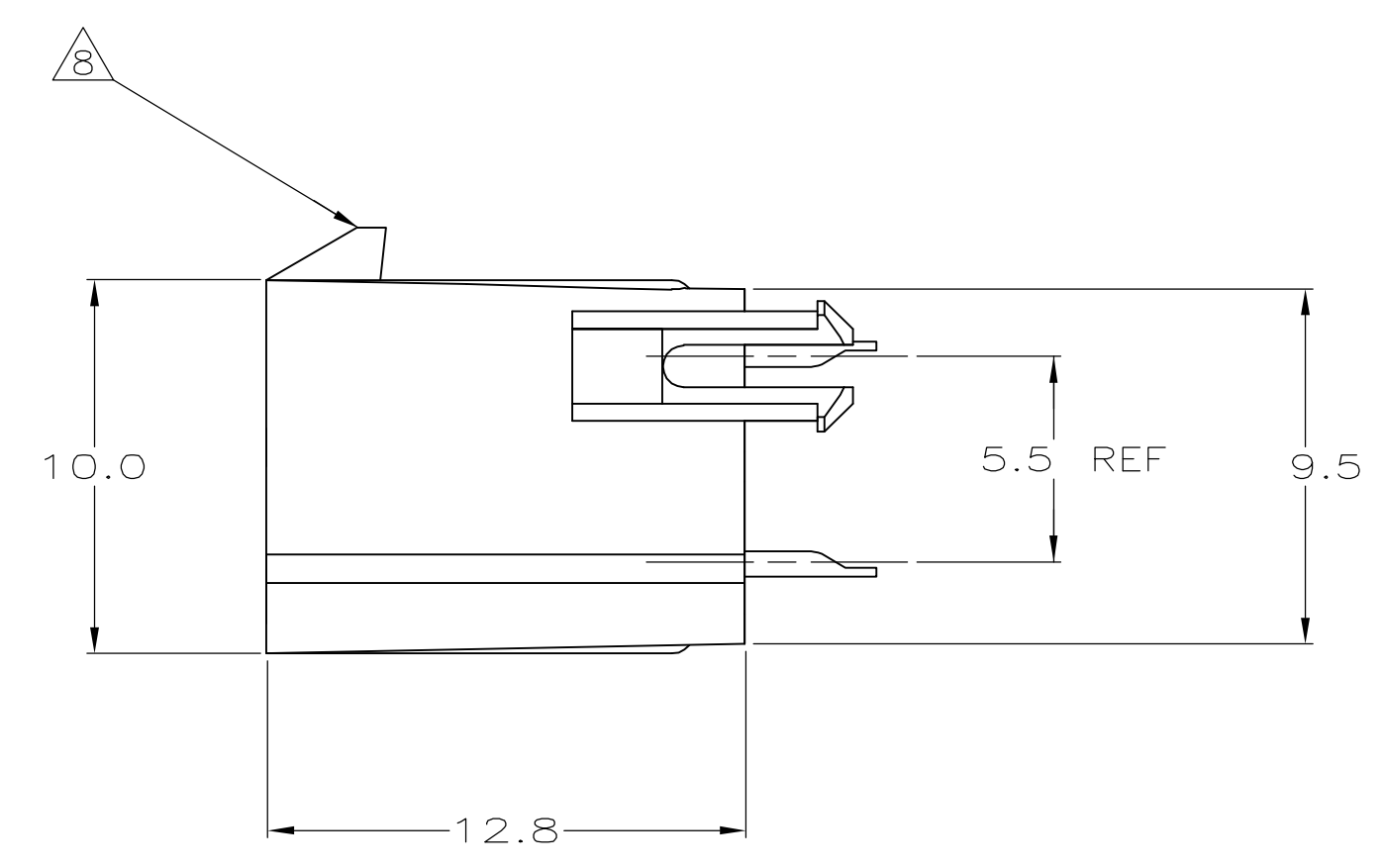
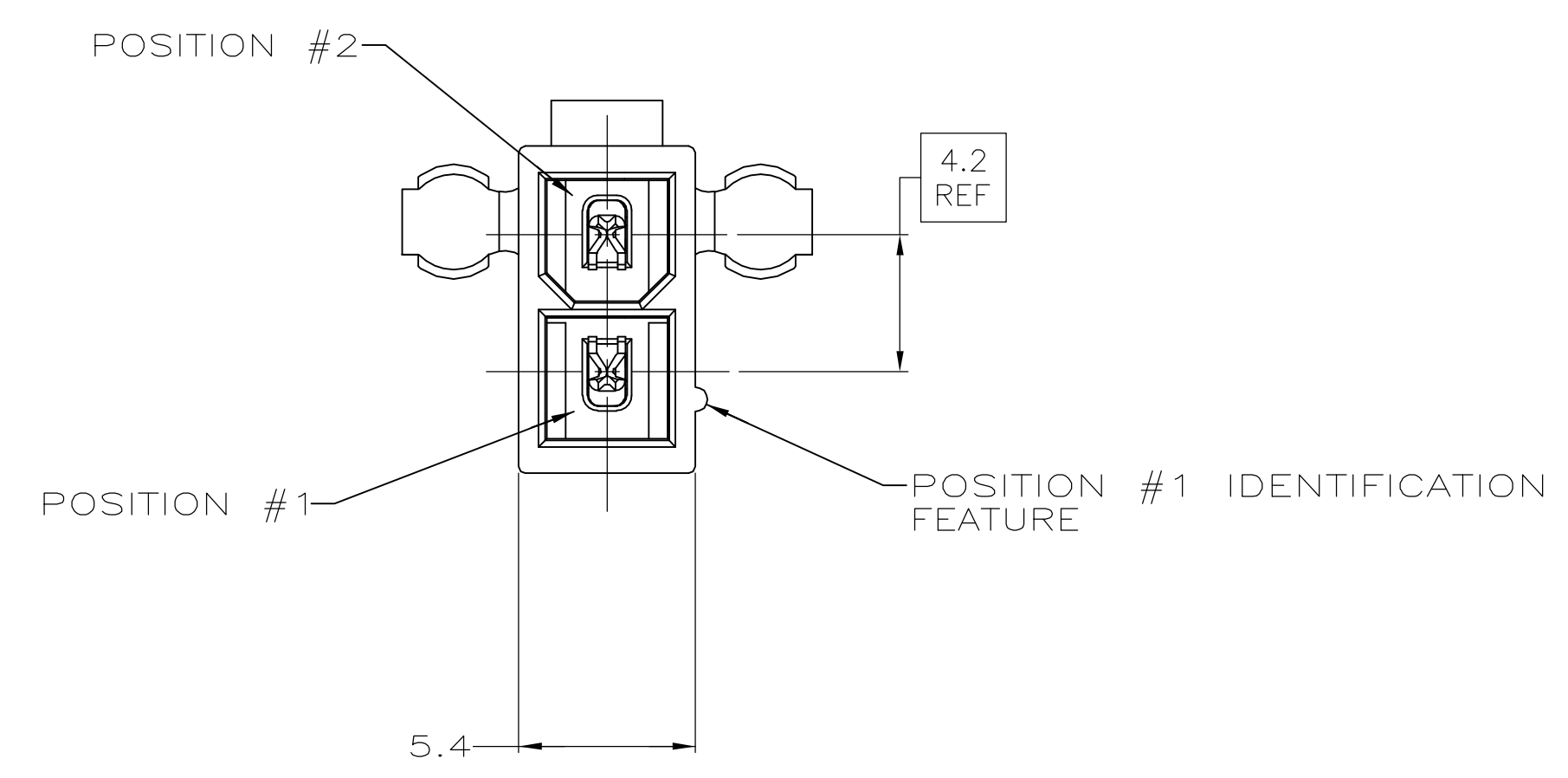

RECOMMENDED MOUNTING HOLE PATTERN
 FOR 1.78 MAX THICK P.C. BOARD
 COMPONENT SIDE SHOWN

1	10	1	1	1-794302-2
1	9	1	1	1-794302-1
1	3	1	1	794302-2
1	2	1	1	794302-1
CONTACT		HOUSING		PART NO
MATERIAL	FINISH	MATERIAL	COLOR	

THIS DRAWING IS A CONTROLLED DOCUMENT.		DWN A.HOLT 11 OCT 99	Tyco Electronics Corporation Harrisburg, Pa 17105-3608	
DIMENSIONS: mm		CHK C.CASH 11 OCT 99	NAME ASSEMBLY, HEADER, VERTICAL, 2 POSITION, W/PEGS, W/DRAIN HOLES, 94V-2,AMP-DUAC	
TOLERANCES UNLESS OTHERWISE SPECIFIED:		APPD C.CASH 11 OCT 99	PRODUCT SPEC 108-1699	
0 PLC ± -		APPLICATION SPEC		
1 PLC ± 0.2		SIZE A1		
2 PLC ± 0.13		CAGE CODE 00779		
3 PLC ± -		DRAWING NO 794302		
4 PLC ± -		RESTRICTED TO		
ANGLES ± 0°30'		WEIGHT -		
FINISH SEE TABLE		CUSTOMER DRAWING		
		SCALE 5:1 SHEET 1 OF 1 REV A		