

ACCEPTS #4 SELF TAPPING SCREW (ELCO HI-LO THREAD CUTTING STYLE OR EQUIVALENT) TO BE DRIVEN AT 0.6±0.2 N-M.

HOUSING COLORS ARE MECHANICALLY KEyed TO MATE ONLY WITH IDENTICALLY COLORED PLUG ASSEMBLIES.

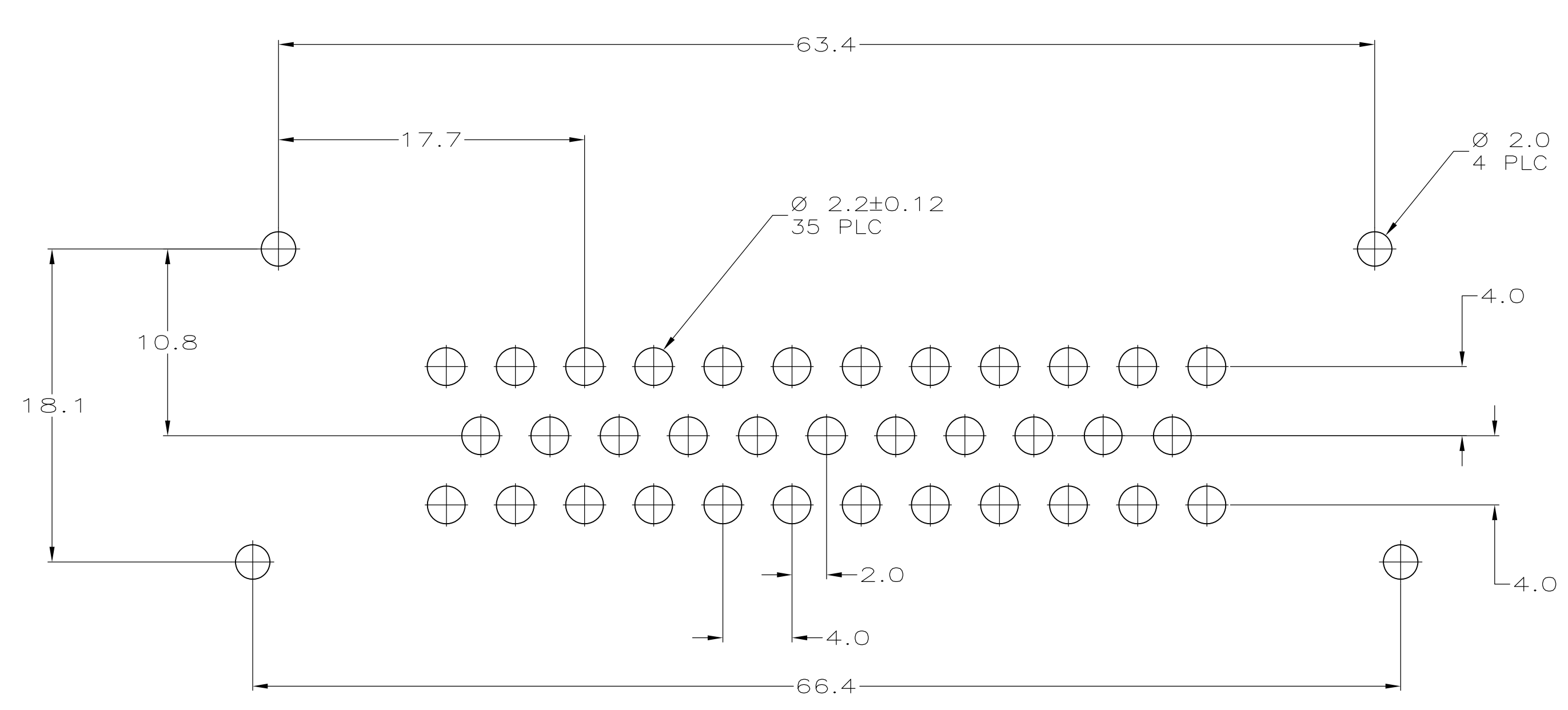

RECOMMENDED P.C. BOARD LAYOUT FOR 1.57 THICK P.C. BOARD

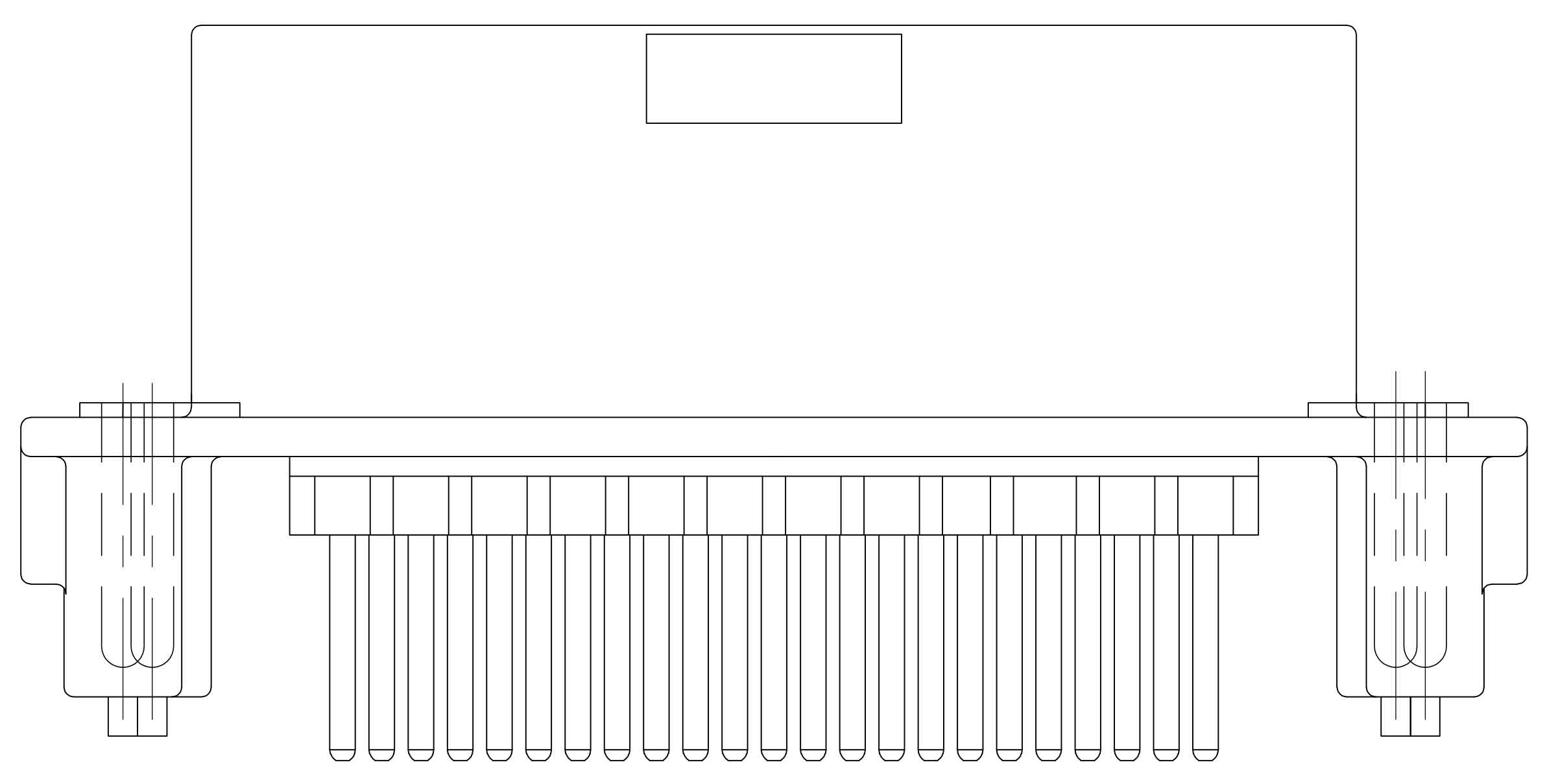
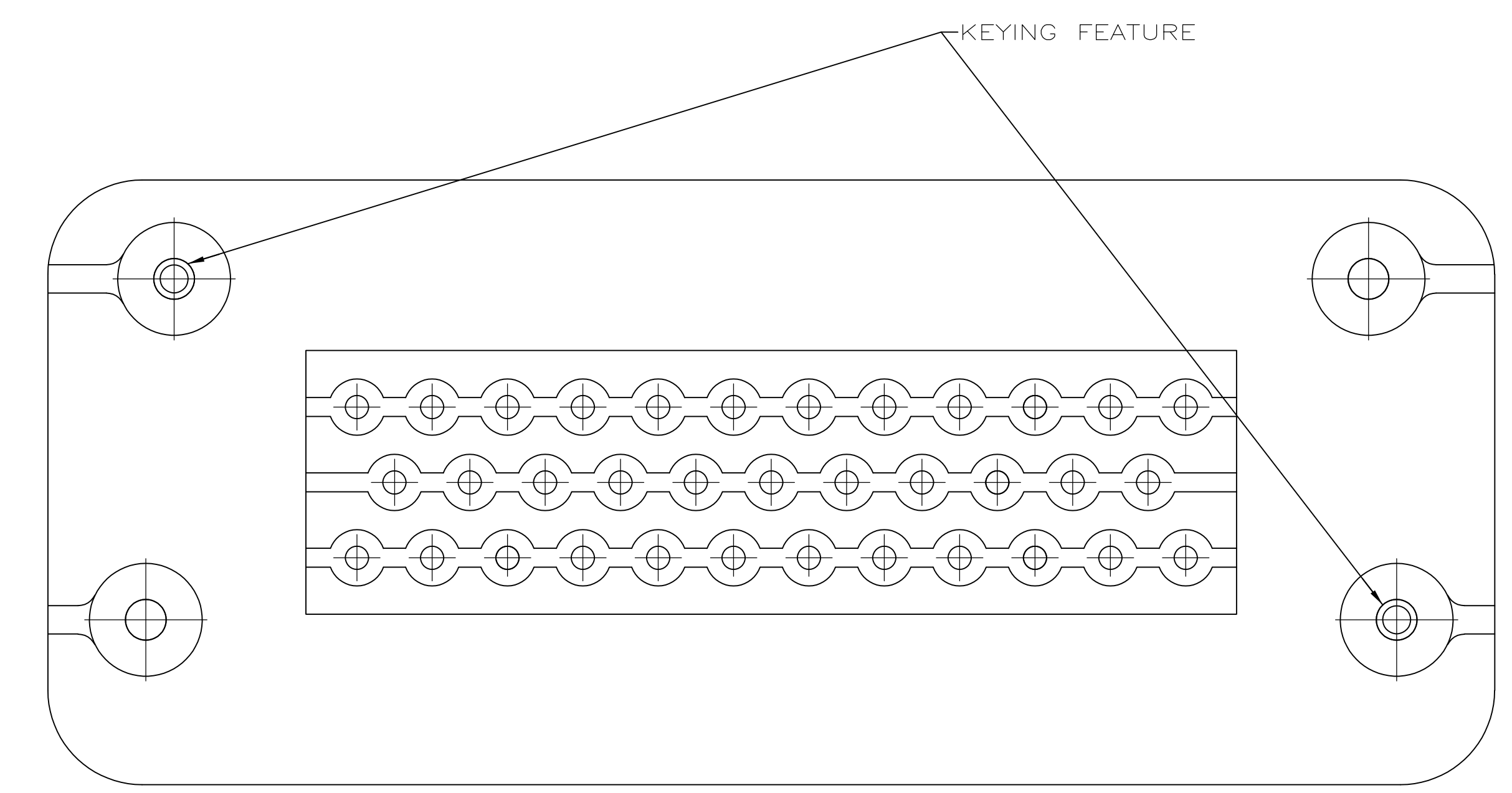

KEYING FOR 776230-1 AND 776230-4

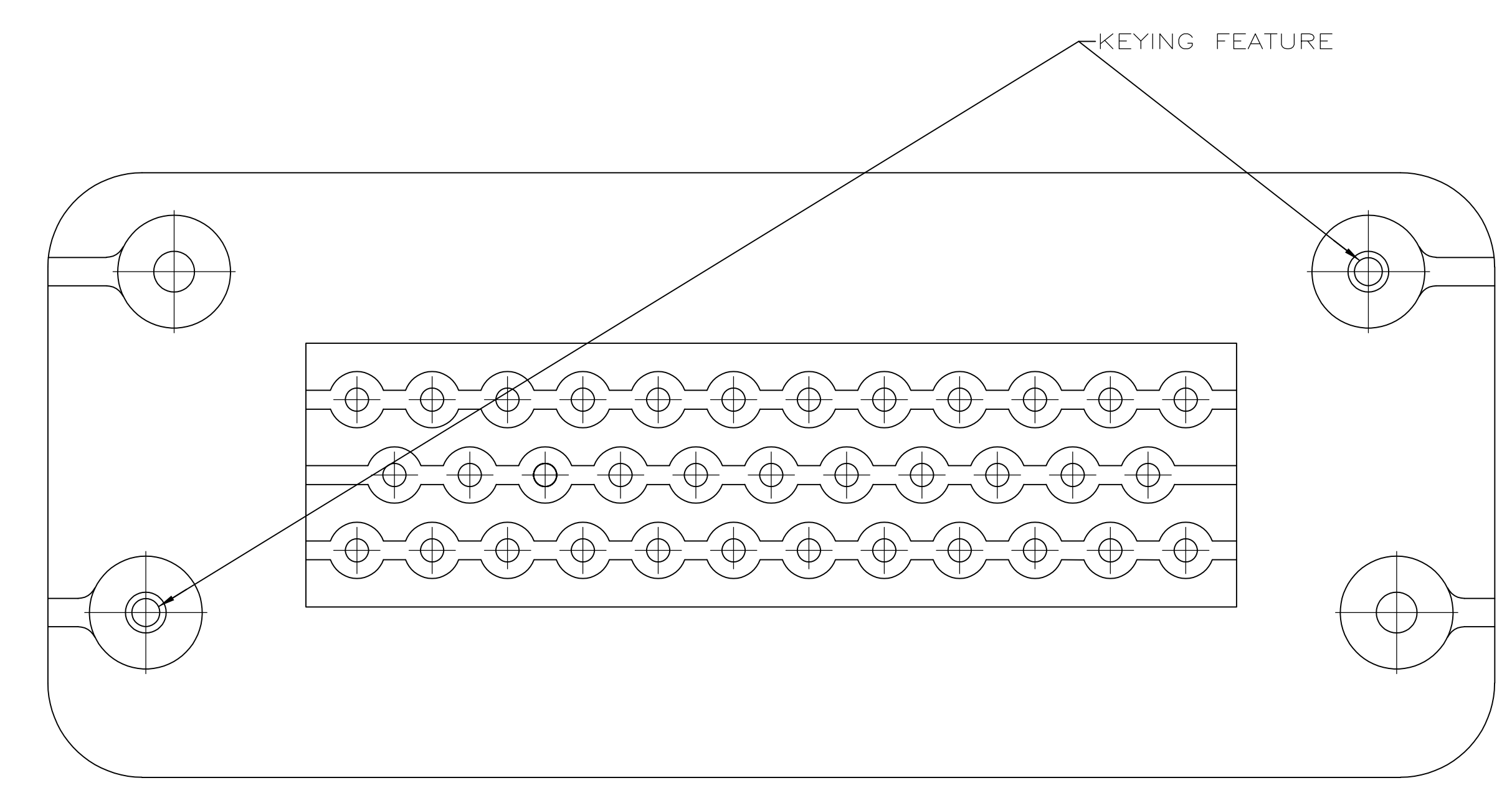

KEYING FOR 776230-2 AND 776230-5

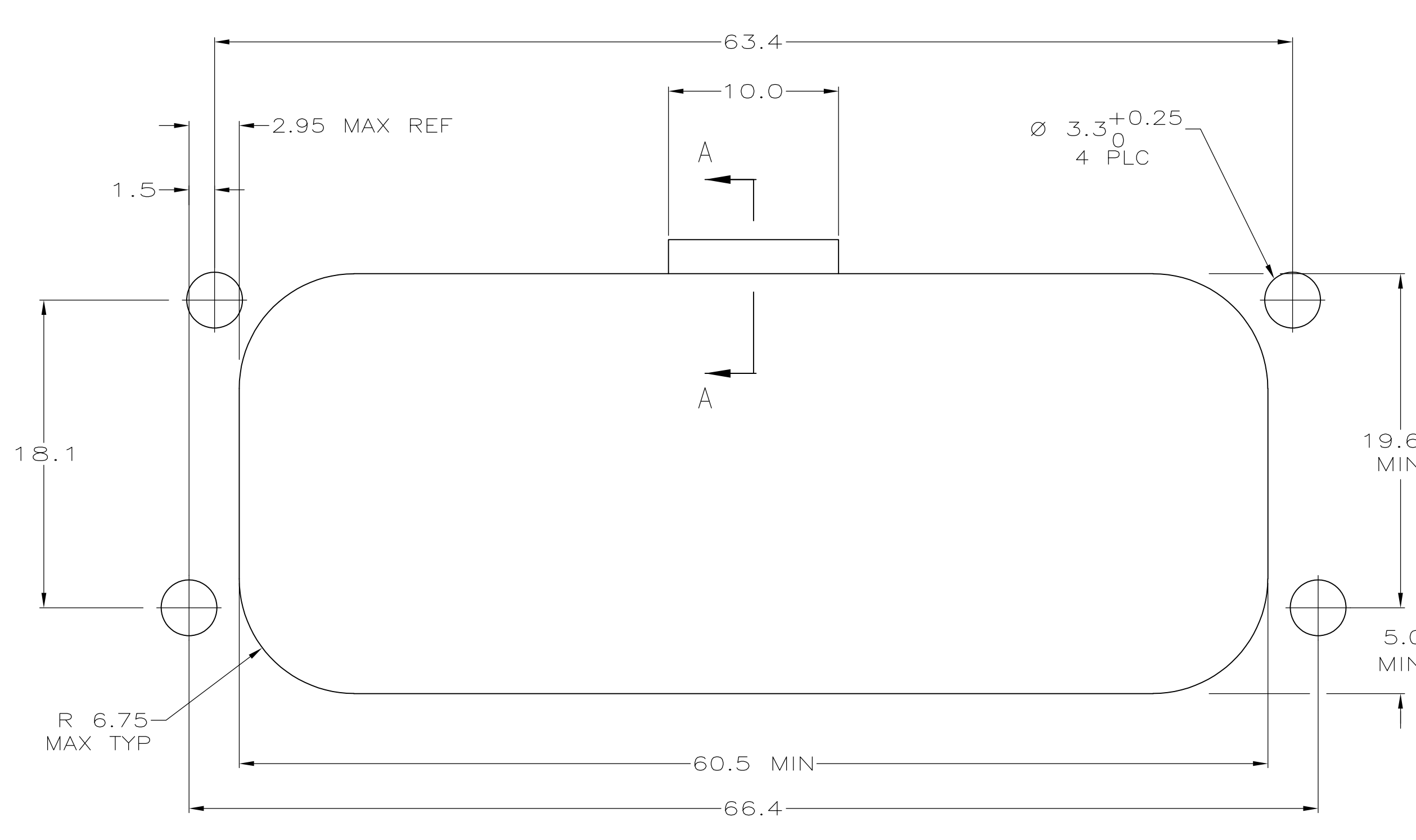

RECOMMENDED MOUNTING HOLE LAYOUT FOR 5.0 MAX THICK PANEL

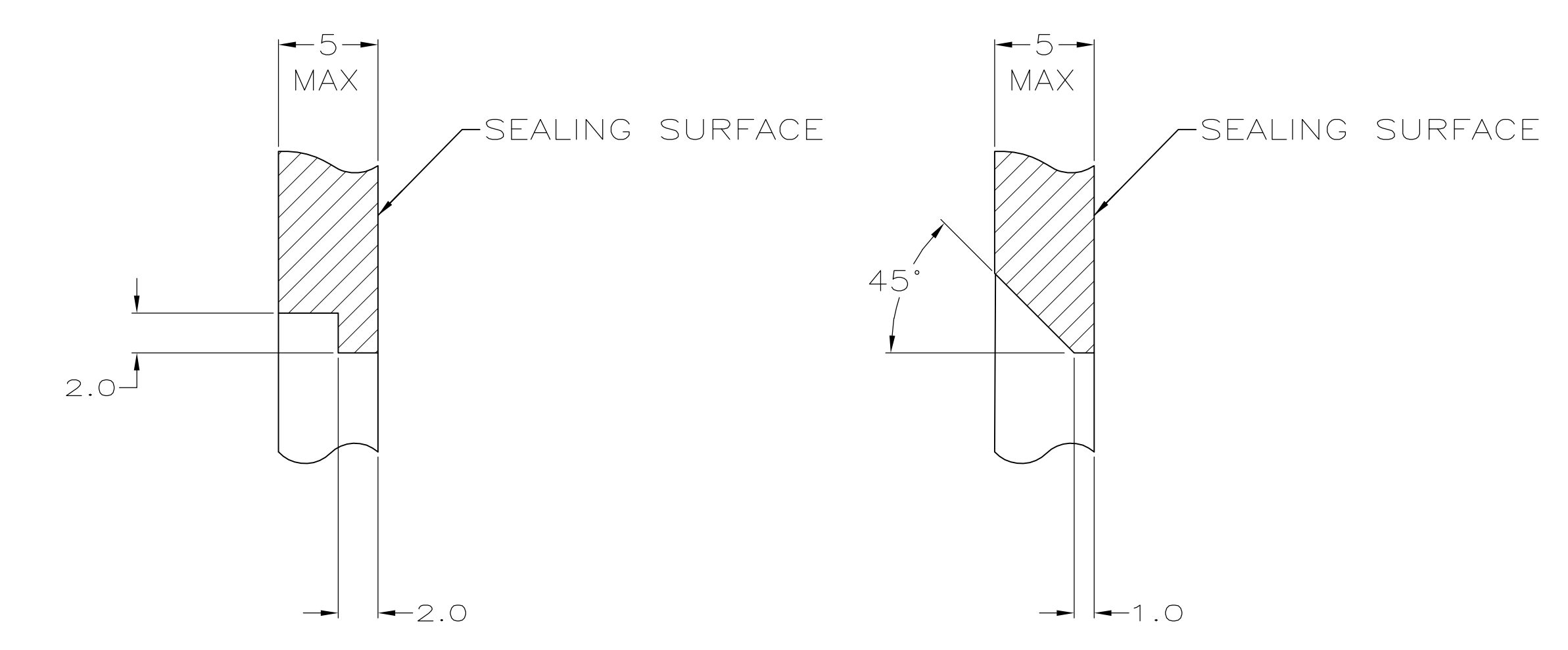

SECTION A-A  
OPTIONAL CONSTRUCTION IF THICKNESS IS GREATER THAN 2.0

SECTION A-A  
OPTIONAL CONSTRUCTION IF THICKNESS IS GREATER THAN 2.0

BRASS, DURA-GOLD PLATED	G.F. PBT, BLUE	1-776230-5
BRASS, DURA-GOLD PLATED	G.F. PBT, GRAY	1-776230-4
BRASS, DURA-GOLD PLATED	G.F. PBT, NATURAL	1-776230-2
BRASS, DURA-GOLD PLATED	G.F. PBT, BLACK	1-776230-1
BRASS, TIN PLATED	G.F. PBT, BLUE	776230-5
BRASS, TIN PLATED	G.F. PBT, GRAY	776230-4
BRASS, TIN PLATED	G.F. PBT, GRAY	776230-3
BRASS, TIN PLATED	G.F. PBT, NATURAL	776230-2
BRASS, TIN PLATED	G.F. PBT, BLACK	776230-1
PIN MATERIAL, FINISH	HOUSING MATERIAL, COLOR	PART NUMBER

THIS DRAWING IS A CONTROLLED DOCUMENT. DATE: 7-21-97. BY: J.C. COLLINS. CHECKED BY: D. STILLIE. APPROVED BY: J. BROWNE. TYPED BY: J. BROWNE. DRAWING NO: 114-16016. SCALE: 4:1. SHEET: 1 OF 1. REV: A2.

TYCO ELECTRONICS CORPORATION  
HARRISBURG, PA 17105-3608

PRODUCT SPEC: 109-1329  
APPLICATION SPEC: 114-16016

HEADER ASSEMBLY, 35 POSITION, VERTICAL AMPSEAL, TM.