

MTA-156 Friction Lock Headers — Right Angle

Material and Finish

Housing — UL94V-0 rated, polyester, white

Posts — Copper alloy, tin plated, .000030 [0.00076] or .000015 [0.00038] gold over nickel

Notes:

1. Post(s) can be omitted for keying purposes. Specify the desired post(s) to be omitted using the figure to identify Post No. 1.
2. Gold headers are duplex plated, gold on mating end of post and tin on the soldertail.
3. .125 [3.18] soldertail lengths are for .062 [1.57] thick printed circuit board and .175 [4.45] soldertail lengths are for .093-.125 [2.36-3.18] thick printed circuit boards.

For mateability options, see matrix on pages 18, 19, 34 and 38.

When using Front Bend Headers—for mating half visuals use connectors with a locking ramp for polarization/retention purposes. When using Rear Bend Headers—for mating half visuals use connectors without a locking ramp for polarization purposes only. See pages 20 thru 23, 35 and 40.

Header Ordering Information

The "Base Part Numbers" Chart at right shows the base part number and number of posts available for the described headers.

Prefixes and suffixes are determined by the number of post positions in the header. For example, the complete part number for a 10-position header with square posts and a .125 [3.18] soldertail length would be:

Base number **640389** plus prefix-and-suffix

1- -0

The correct ordering number is

1-640389-0

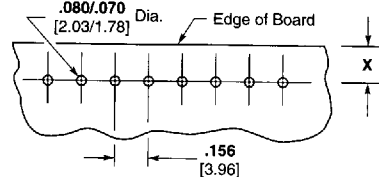
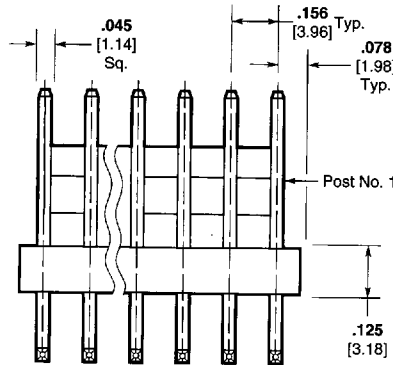
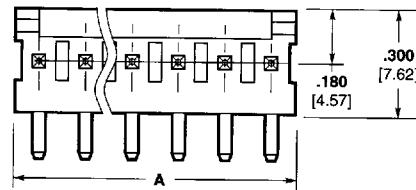

Recommended Mounting Hole Size for a .062 [1.57] Thk. PC Board

Y = .068 [1.73] 2-8 position tin plated and 2-24 position gold plated headers.

Y = .073 [1.85] 9-24 position tin plated headers.

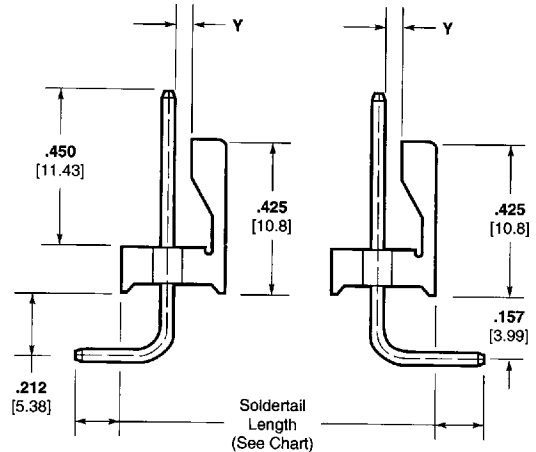

Front Bend

X = .325 [8.26] Min., .400 [10.16] Max., when mated with MTA Connector.
X = .325 [8.26] Min., .345 [8.76] Max., when mated with SL-156 Connector.

Rear Bend

X = .500 [12.7] Min., .650 [16.51] Max., when mated with MTA Connector.
X = .500 [12.7] Min., when mated with SL-156 Connector.

Base Part Numbers

Front Bend				Rear Bend			
.125 [3.18] Soldertail		.175 [4.45] Soldertail		.125 [3.18] Soldertail		.175 [4.45] Soldertail	
Header Part Nos.	No. of Posts	Header Part Nos.	No. of Posts	Header Part Nos.	No. of Posts	Header Part Nos.	No. of Posts
Standard UL94V-0, Tin Plated							
640389	2-24	644754	2-24	640387	2-24	644755	2-24
Standard UL94V-0, .000030 [0.00076] Gold Plated							
641210	2-24	644761	2-24	641207	2-24	644762	2-24
Standard UL94V-0, .000015 [0.00038] Gold Plated							
641121	2-24	644768	2-24	641118	2-24	644769	2-24



Header Length

No. of Posts	Dim. A	Prefix/Suffix	No. of Posts	Dim. A	Prefix/Suffix	No. of Posts	Dim. A	Prefix/Suffix
2	.312 7.92	-2	10	1.560 39.62	1--0	18	2.808 71.32	1--8
3	.468 11.89	-3	11	1.716 43.59	1--1	19	2.964 75.29	1--9
4	.624 15.85	-4	12	1.872 47.55	1--2	20	3.120 79.25	2--0
5	.780 19.81	-5	13	2.028 51.51	1--3	21	3.276 83.21	2--1
6	.936 23.77	-6	14	2.184 55.47	1--4	22	3.432 87.17	2--2
7	1.092 27.74	-7	15	2.340 59.44	1--5	23	3.588 91.14	2--3
8	1.248 31.7	-8	16	2.496 63.4	1--6	24	3.744 95.1	2--4
9	1.404 35.66	-9	17	2.652 67.36	1--7			

For drawings, technical data or samples, contact your AMP sales engineer or call the AMP Product Information Center 1-800-522-6752. Dimensions are in inches and millimeters unless otherwise specified. Values in brackets are metric equivalents. Specifications subject to change. Consult AMP for latest specifications.

.156 [3.96] Centerline MTA-156 IDC Connectors and Headers

Product Facts

- Connectors and headers for 2 through 24 positions; wire sizes of 18, 20, 22, 24 and 26 AWG [0.9–0.12 mm²]
- Wire-to-post connectors preloaded with dual beam contacts
- Connectors and headers are end-to-end stackable
- QUAD Connectors for higher current rating
- Posted connectors for 2, 3, 4, 6, 9, 12, 15 and 24 positions
- Card edge connectors for 3, 6, 9, 12, 15, 18 and 20 through 24 positions
- Connectors preloaded with IDC contacts
- All contacts are slotted for insulation displacement (IDC) termination technique
- Connector styles include both closed end and feed-thru, with and without locking ramps and polarizing tabs
- Contacts are lubricated to prevent fretting corrosion
- Benefits derived from the MTA-156 system include increases quality and ease of handling such as —
 - One step assembly
 - No wire stripping
 - No contact damage
 - Reduced wiring errors
 - Simpler tooling
 - Simple maintenance and repair
- Meets the material requirements of Table 23.1 of UL 1410 Standards for Television Receiver and Video Products (wire-to-post connectors only)
- Recognized under the Component Program of Underwriters Laboratories Inc.,  File No. E28476
- Certified by Canadian Standards Association  File No. LR7189

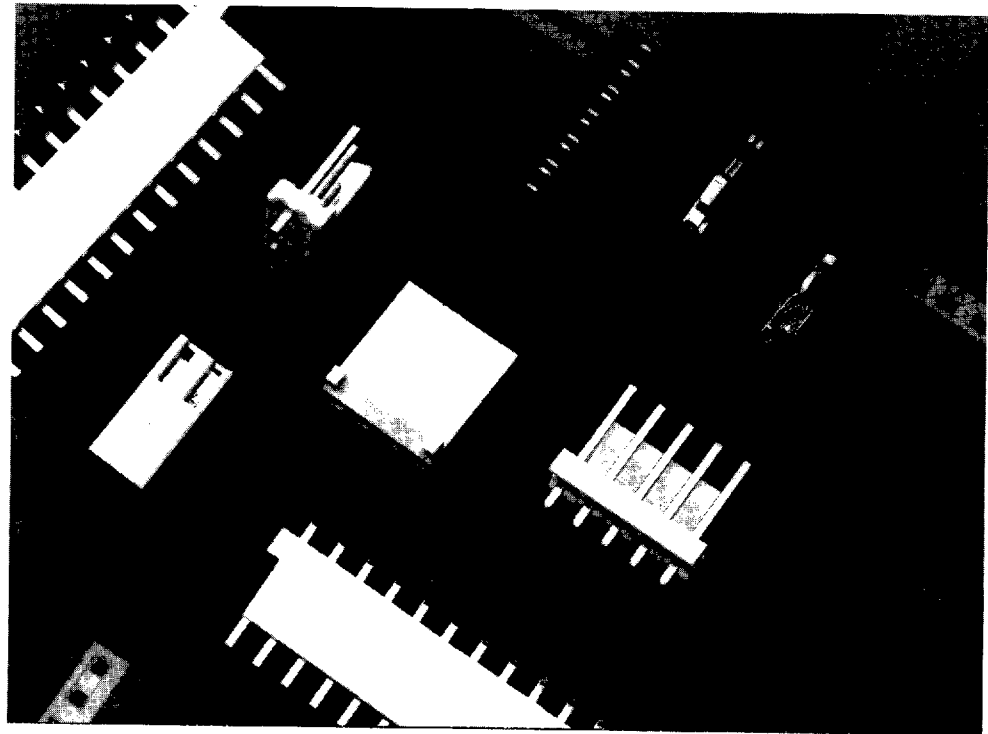

MTA-156 connectors accept discrete and ribbon cable wire sizes ranging from 18–26 AWG [0.9–0.12 mm²] with maximum insulation outside diameter .095 [2.41] for single wire and .070 [1.78] for mass termination of wires. Tin plated solid, fused stranded or stranded (7, 16, and 19 strands) wire with PVC insulation can be used on 18 AWG [0.8–0.9 mm²] MTA-156 connectors; 7, 10, and 19 stranded wire on 20 AWG [0.5–0.6 mm²] MTA-156 connectors; and 7 and 19 stranded wire on 22–26 AWG [0.4–0.12 mm²] MTA-156 connectors.

Only one wire to be terminated into an IDC contact slot.

Mass termination of wire provides the lowest applied cost because it drastically reduces the labor content of virtually any cable or harness assembly required.

The wire-to-post connector housing material is flame retardant thermoplastic, either UL94V-2 or UL94V-0 rated.

A full line of .156 [3.96] centerline headers completes the system. Headers are available with straight or right angle posts, in flat or friction lock styles. Headers are available in 2 through 24 positions.

Performance Data*

Voltage Rating — 250 vac

Current Rating — 5 amp max. for MTA-156 Connector

Low-Level Resistance — 3.0 mΩ max. initial

Dielectric Withstanding Voltage — 1250 vac/1 min.

Insulation Resistance — 5000 MΩ min. initial

Operating Temperature — –55° C to +105° C

*Refer to the Product Specification for additional electrical, mechanical and environmental performance tests and requirements.

Technical Documents

Product Specification

108-1051 MTA-156 Connectors

Application Specifications

114-1020 MTA-156 Connectors, Posted Connectors and Card Edge Connectors

114-1032 MTA-156 Ribbon Cable Assembly

Note: Refer to pages 42 thru 46 for approved wire listings.

MTA-156
.156 [3.96]