

61048-1 ✓ ACTIVE

FASTON | FASTON 110

TE Internal #: 61048-1

Quick Disconnects, Receptacle, 22 – 18 AWG Wire Size, .26 – .96 mm<sup>2</sup> Wire Size, 509 – 1900 CMA Wire Size, Mating Tab Width .11 in [2.79 mm], FASTON 110

[View on TE.com >](#)



Terminals & Splices > Quick Disconnects

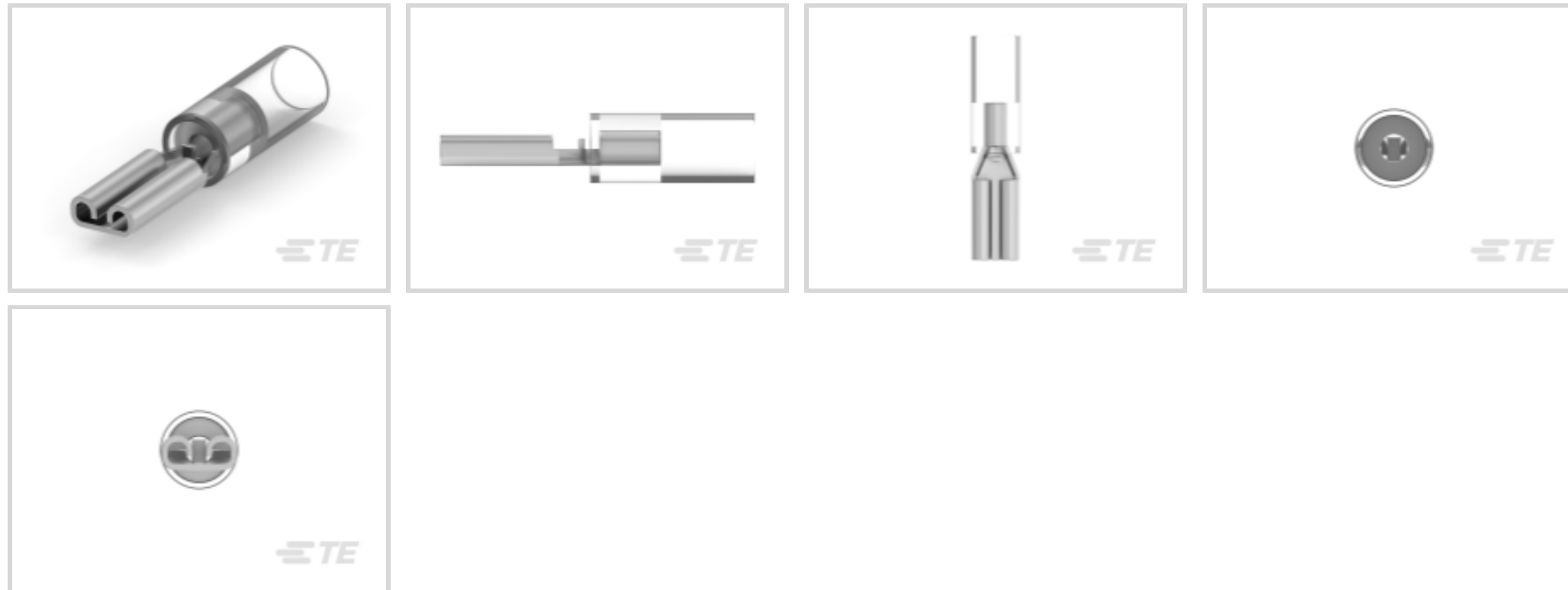

Quick Disconnect Terminal Type: **Receptacle**

Wire Size: **509 – 1900 CMA**

Mating Tab Width: **2.79 mm [ .11 in ]**

## Features

### Product Type Features

Terminates To	Wire & Cable
Wire Stop	Yes
Insertion Force	Normal
Sealable	No

### Electrical Characteristics

Voltage (Max)	300 V
---------------	-------

### Body Features

Insulation Material	Nylon
---------------------	-------

### Contact Features

Quick Disconnect Terminal Type	Receptacle
Mating Tab Width	2.79 mm [.11 in]
Mating Tab Thickness	.41 mm [.016 in]
Terminal Orientation	Straight
Contact Base Material	Brass
Terminal Plating Material	Tin



Crimp Type	Compression
------------	-------------

Barrel Type	Closed
-------------	--------

### Mechanical Attachment

Mating Retention Type	Dimple
-----------------------	--------

Wire Insulation Support	With
-------------------------	------

### Dimensions

Accepts Wire Insulation Diameter Range	2.54 mm[.1 in]
--	----------------

Receptacle Terminal Stock Thickness	.3 mm[.012 in]
-------------------------------------	----------------

Overall Length	18.64 mm[.734 in]
----------------	-------------------

Wire Size	509 – 1900 CMA
-----------	----------------

### Usage Conditions

Insulation Option	Partially Insulated
-------------------	---------------------

Operating Temperature Range	105 °C[221 °F]
-----------------------------	----------------

### Industry Standards

RU (UL Component Program)	No
---------------------------	----

CSA Certified	No
---------------	----

### Packaging Features

Packaging Quantity	1000
--------------------	------

Packaging Method	Loose Piece
------------------	-------------

### Other

Barrel Color	Clear
--------------	-------

### Product Compliance

[For compliance documentation, visit the product page on TE.com>](#)

EU RoHS Directive 2011/65/EU	Compliant
------------------------------	-----------

EU ELV Directive 2000/53/EC	Compliant
-----------------------------	-----------

China RoHS 2 Directive MIIT Order No 32, 2016	No Restricted Materials Above Threshold
---	---

EU REACH Regulation (EC) No. 1907/2006	Current ECHA Candidate List: JUNE 2022 (224) Candidate List Declared Against: JAN 2022 (223) SVHC > Threshold: Not Yet Reviewed
--	--

Halogen Content	Low Halogen - Br, Cl, F, I < 900 ppm per
-----------------	--



homogenous material. Also BFR/CFR/PVC Free

Solder Process Capability

Not applicable for solder process capability

Product Compliance Disclaimer

This information is provided based on reasonable inquiry of our suppliers and represents our current actual knowledge based on the information they provided. This information is subject to change. The part numbers that TE has identified as EU RoHS compliant have a maximum concentration of 0.1% by weight in homogenous materials for lead, hexavalent chromium, mercury, PBB, PBDE, DBP, BBP, DEHP, DIBP, and 0.01% for cadmium, or qualify for an exemption to these limits as defined in the Annexes of Directive 2011/65/EU (RoHS2). Finished electrical and electronic equipment products will be CE marked as required by Directive 2011/65/EU. Components may not be CE marked. Additionally, the part numbers that TE has identified as EU ELV compliant have a maximum concentration of 0.1% by weight in homogenous materials for lead, hexavalent chromium, and mercury, and 0.01% for cadmium, or qualify for an exemption to these limits as defined in the Annexes of Directive 2000/53/EC (ELV). Regarding the REACH Regulation, the information TE provides on SVHC in articles for this part number is based on the latest European Chemicals Agency (ECHA) 'Guidance on requirements for substances in articles' posted at this URL: <https://echa.europa.eu/guidance-documents/guidance-on-reach>

### Compatible Parts



### Also in the Series | FASTON 110

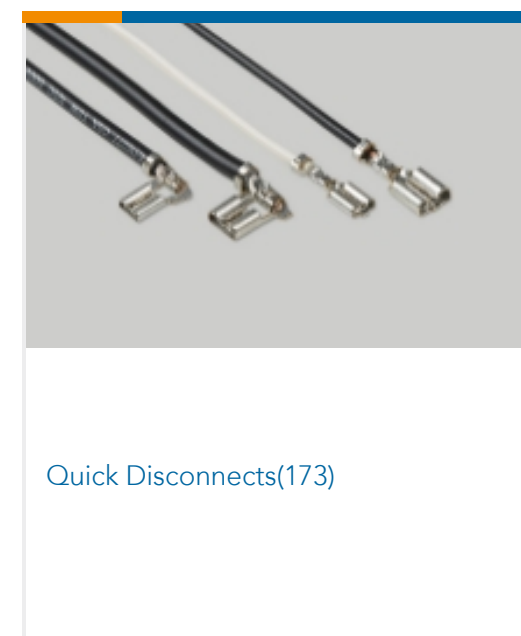
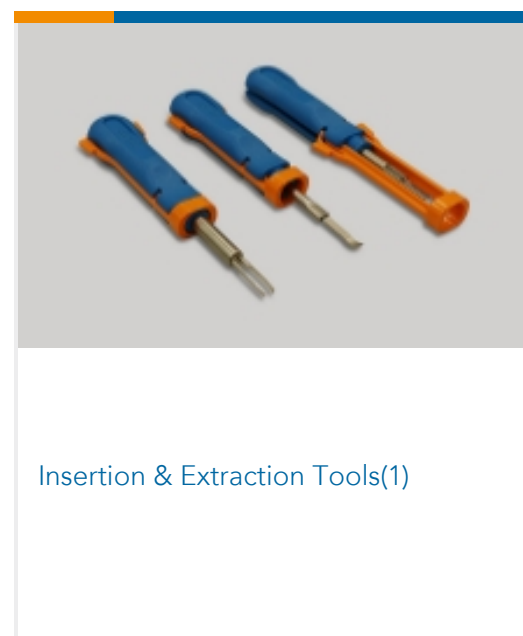
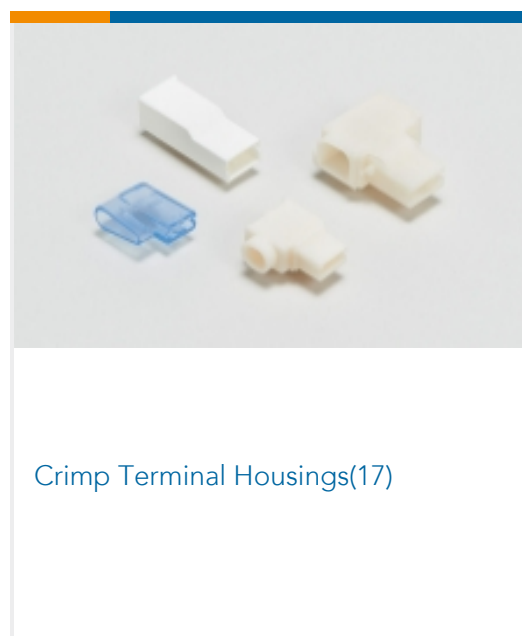

### Customers Also Bought

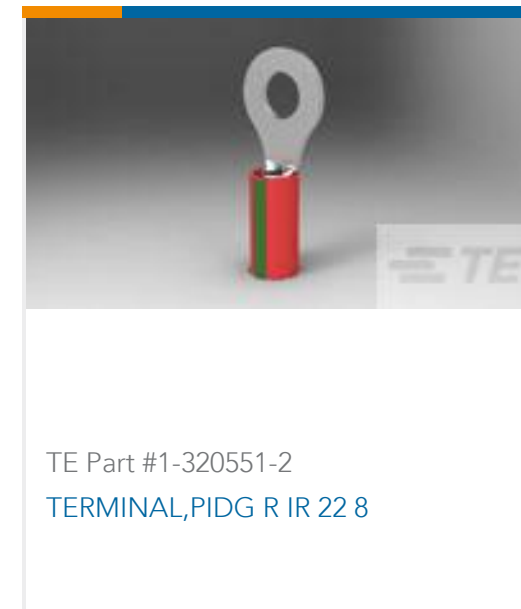

## Documents

### Product Drawings

[RECEPT, PIDG FASTON 22-18 110](#)

English

### CAD Files

[3D PDF](#)

3D

Customer View Model

[ENG\\_CVM\\_CVM\\_61048-1\\_N.2d\\_dxf.zip](#)

English

Customer View Model

[ENG\\_CVM\\_CVM\\_61048-1\\_N.3d\\_igs.zip](#)

English

Customer View Model

[ENG\\_CVM\\_CVM\\_61048-1\\_N.3d\\_stp.zip](#)

English

By downloading the CAD file I accept and agree to the [Terms and Conditions](#) of use.

### Datasheets & Catalog Pages



## PIDG\_FASTON

English

### Ultra-Fast and Ultra Fast Plus

English

---

### Product Specifications

#### Application Specification

English

---

### Product Environmental Compliance

#### TE Material Declaration

English

---

### Agency Approvals

#### CSA Certificate

English