

60422-3 ✓ ACTIVE

TE Internal #: 60422-3

Ring Terminals & Spade Terminals, Ring Tongue, 22 – 20 AWG

Wire Size, .3 – .6 mm² Wire Size, 642 – 1021 CMA Wire Size, Stud Size M2 / #2

[View on TE.com >](#)



Terminals & Splices > Ring Terminals & Spade Terminals



Ring & Spade Terminal Type: **Ring Tongue**

Wire Size: **642 – 1021 CMA**

Stud Size: **#2, M2**

Features

Product Type Features

Shape Description	Circular/Oval
Stud Size	#2, M2
Sealable	No
Compatible With Discrete Wire Type	Stranded
Wire Insulation Support Retention Type	Insulation Piercing

Configuration Features

Number of Holes	1
Terminal Angle	180 °

Contact Features

Contact Base Material	Brass
Ring & Spade Terminal Type	Ring Tongue
Barrel Type	Open
Terminal Orientation	Straight
Terminal Plating Material	Nickel
Contact Underplating Material	None

Mechanical Attachment



Wire Insulation Support	With
-------------------------	------

Dimensions

	.049 in
Wire Size	642 – 1021 CMA
Stud Diameter	2.44 mm[.096 in]
Tongue Thickness	.33 mm[.013 in]
Overall Product Length	10.67 mm[.42 in]
Barrel Inside Diameter	1.49 mm[.059 in]
Accepts Wire Insulation Diameter (Max)	1.65 mm[.065 in]
Accepts Wire Insulation Diameter Range	1.27 – 1.65 mm[.05 – .065 in]

Usage Conditions

Insulation Option	Uninsulated
Operating Temperature Range	-40 – 250 °C[-40 – 482 °F]

Operation/Application

Compatible With Wire Base Material	Copper
Heavy Duty	No

Industry Standards

Government Qualified	No
----------------------	----

Packaging Features

Packaging Quantity	25000
Packaging Method	Strip/Reel

Product Compliance

[For compliance documentation, visit the product page on TE.com>](#)

EU RoHS Directive 2011/65/EU	Compliant
EU ELV Directive 2000/53/EC	Compliant
China RoHS 2 Directive MIIT Order No 32, 2016	No Restricted Materials Above Threshold
EU REACH Regulation (EC) No. 1907/2006	Current ECHA Candidate List: JUNE 2022 (224) Candidate List Declared Against: JAN 2022 (223) SVHC > Threshold: Not Yet Reviewed
Halogen Content	Low Halogen - Br, Cl, F, I < 900 ppm per

homogenous material. Also BFR/CFR/PVC Free

Solder Process Capability

Not applicable for solder process capability

Product Compliance Disclaimer

This information is provided based on reasonable inquiry of our suppliers and represents our current actual knowledge based on the information they provided. This information is subject to change. The part numbers that TE has identified as EU RoHS compliant have a maximum concentration of 0.1% by weight in homogenous materials for lead, hexavalent chromium, mercury, PBB, PBDE, DBP, BBP, DEHP, DIBP, and 0.01% for cadmium, or qualify for an exemption to these limits as defined in the Annexes of Directive 2011/65/EU (RoHS2). Finished electrical and electronic equipment products will be CE marked as required by Directive 2011/65/EU. Components may not be CE marked. Additionally, the part numbers that TE has identified as EU ELV compliant have a maximum concentration of 0.1% by weight in homogenous materials for lead, hexavalent chromium, and mercury, and 0.01% for cadmium, or qualify for an exemption to these limits as defined in the Annexes of Directive 2000/53/EC (ELV). Regarding the REACH Regulation, the information TE provides on SVHC in articles for this part number is based on the latest European Chemicals Agency (ECHA) 'Guidance on requirements for substances in articles' posted at this URL: <https://echa.europa.eu/guidance-documents/guidance-on-reach>

Compatible Parts



TE Part # 2-2150729-1
OCEAN_2.0_Applicator-E-0900



TE Part # 2-2150729-2
OCEAN_2.0_Applicator-E-0900



TE Part # 2150729-1
OCEAN_2.0_Applicator-E-0900



TE Part # 2150729-2
OCEAN_2.0_Applicator-E-0900



TE Part # 7-2150729-1
OCEAN_2.0_Applicator-E-0900



TE Part # 7-2150729-2
OCEAN_2.0_Applicator-E-0900



TE Part # 7-2150729-7
OCEAN_2.0_SPARE_PART_KIT-0900

Customers Also Bought



TE Part #330648
PIDG RING TONGUE TERMINALS



TE Part #499252-6
034 STRAIN RELIEF A-L RCPT



TE Part #32859
TERMINAL,BUDG R 26-22 8



TE Part #1375819-2
CST-100 II CONTACT 15 GOLD PLT

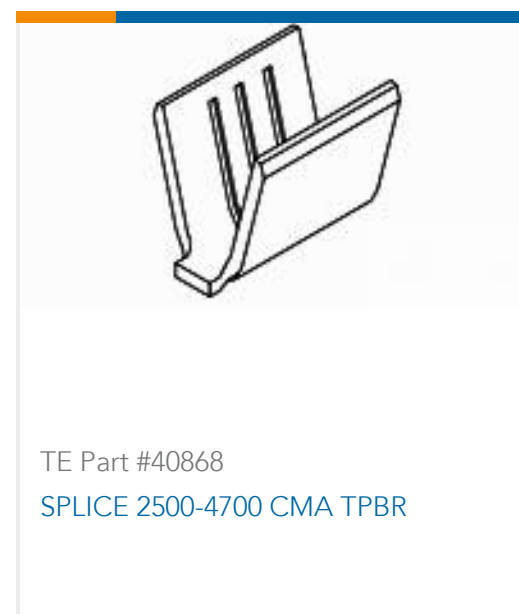
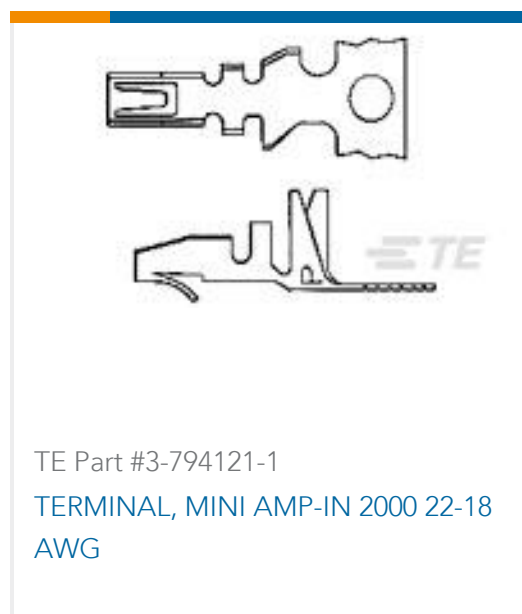

Documents

Product Drawings

RING 22-20 AWG NPBR

English

CAD Files

3D PDF

3D

Customer View Model

[ENG_CVM_CVM_60422-3_AH_c-60422-3-ah.2d_dxf.zip](#)

English

Customer View Model

[ENG_CVM_CVM_60422-3_AH_c-60422-3-ah.3d_igs.zip](#)

English

Customer View Model

[ENG_CVM_CVM_60422-3_AH_c-60422-3-ah.3d_stp.zip](#)

English

By downloading the CAD file I accept and agree to the [Terms and Conditions](#) of use.

Product Specifications

Application Specification

English

Agency Approvals

UL Report

English