

THIS DRAWING IS UNPUBLISHED. RELEASED FOR PUBLICATION 20  
 © COPYRIGHT 20 BY TYCO ELECTRONICS CORPORATION. ALL INTERNATIONAL RIGHTS RESERVED.

LOC	DIST	REVISIONS					
J	-	P	LTR	DESCRIPTION	DATE	DWN	APVD
		F		REVISED	26JAN2011	T.S	N.Y
		FI		ADD P/N 6376610-3	18OCT2018	A.W	R.B

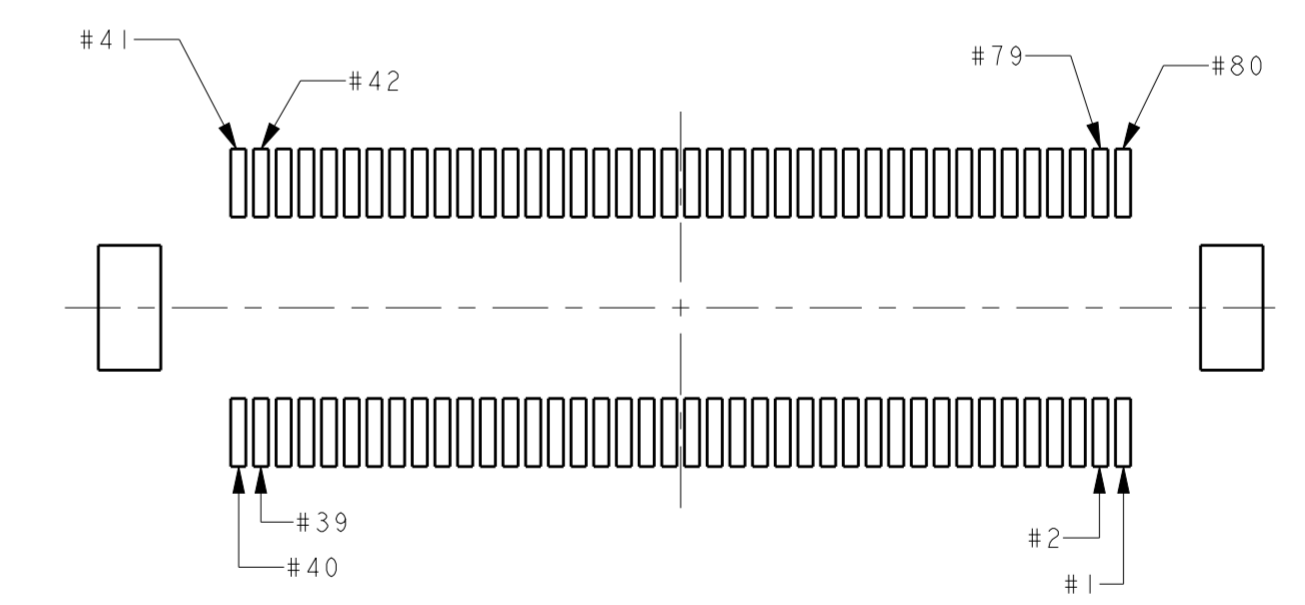
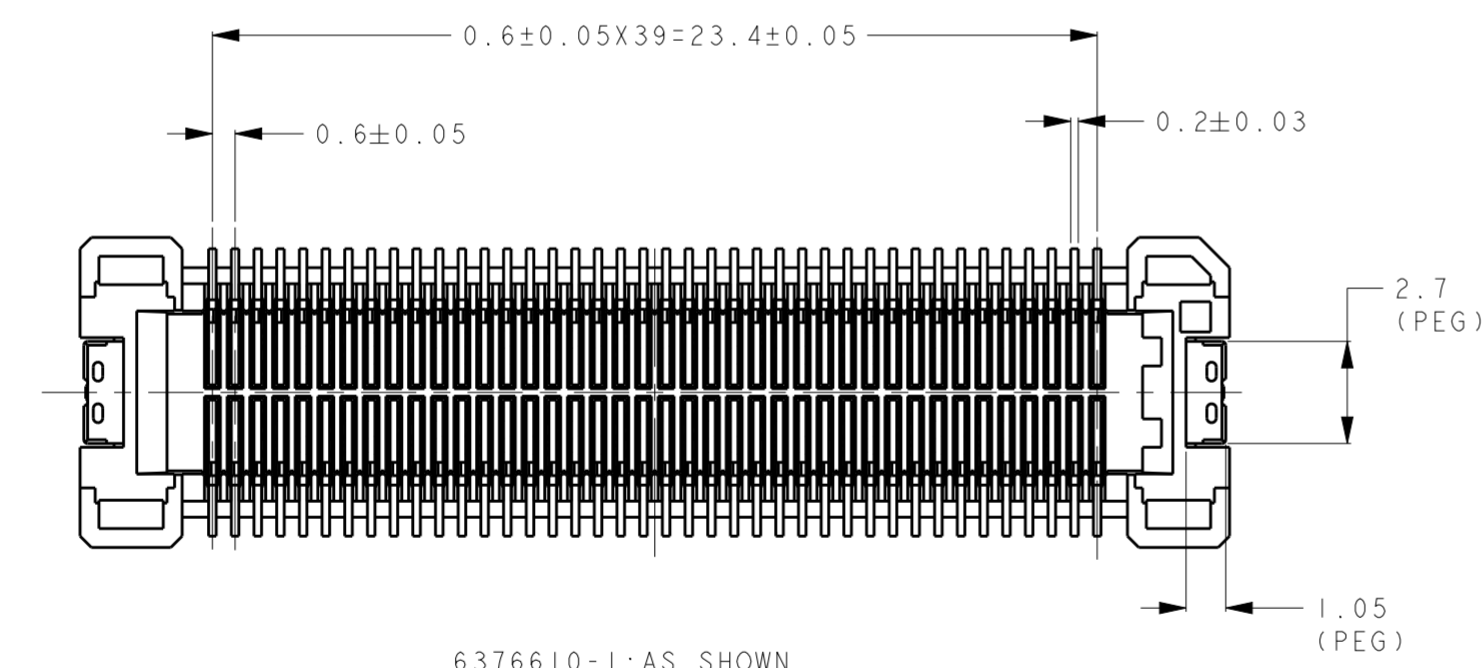
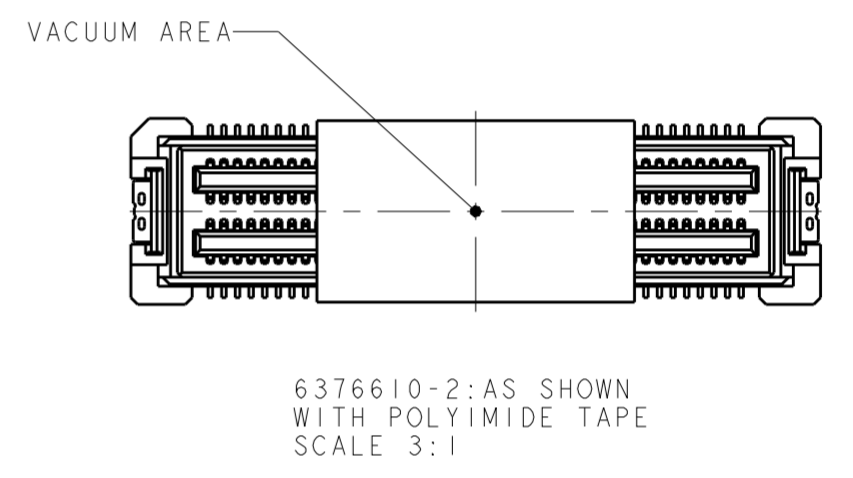
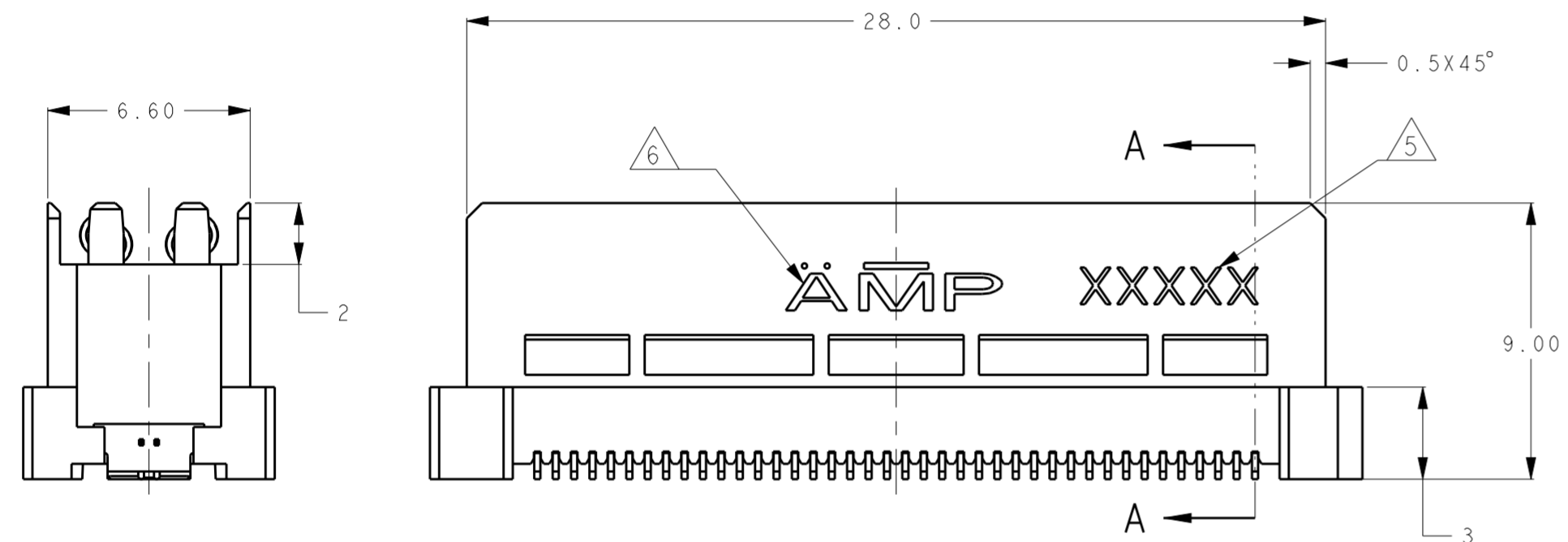
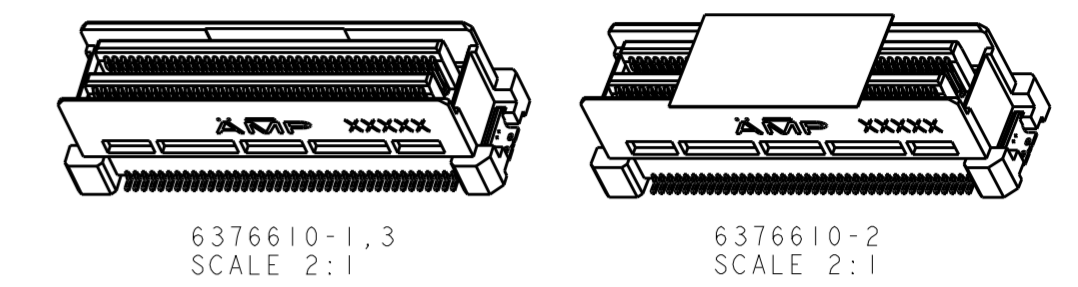
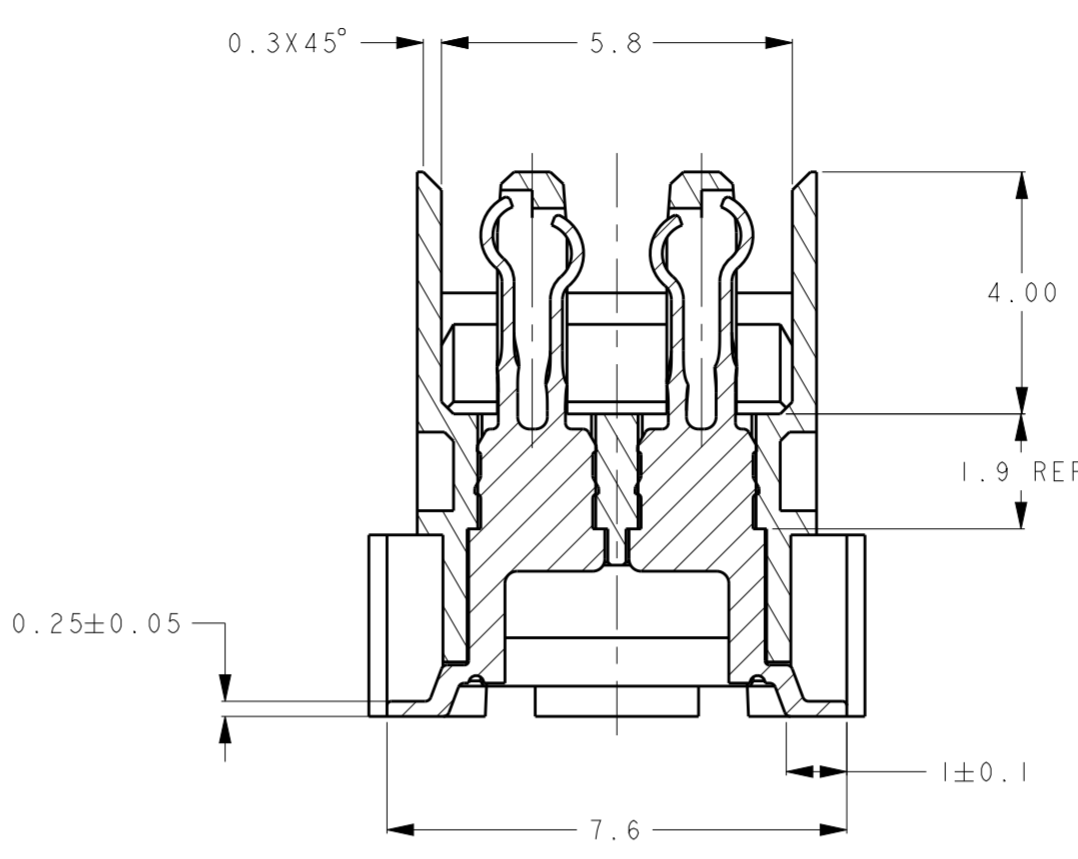
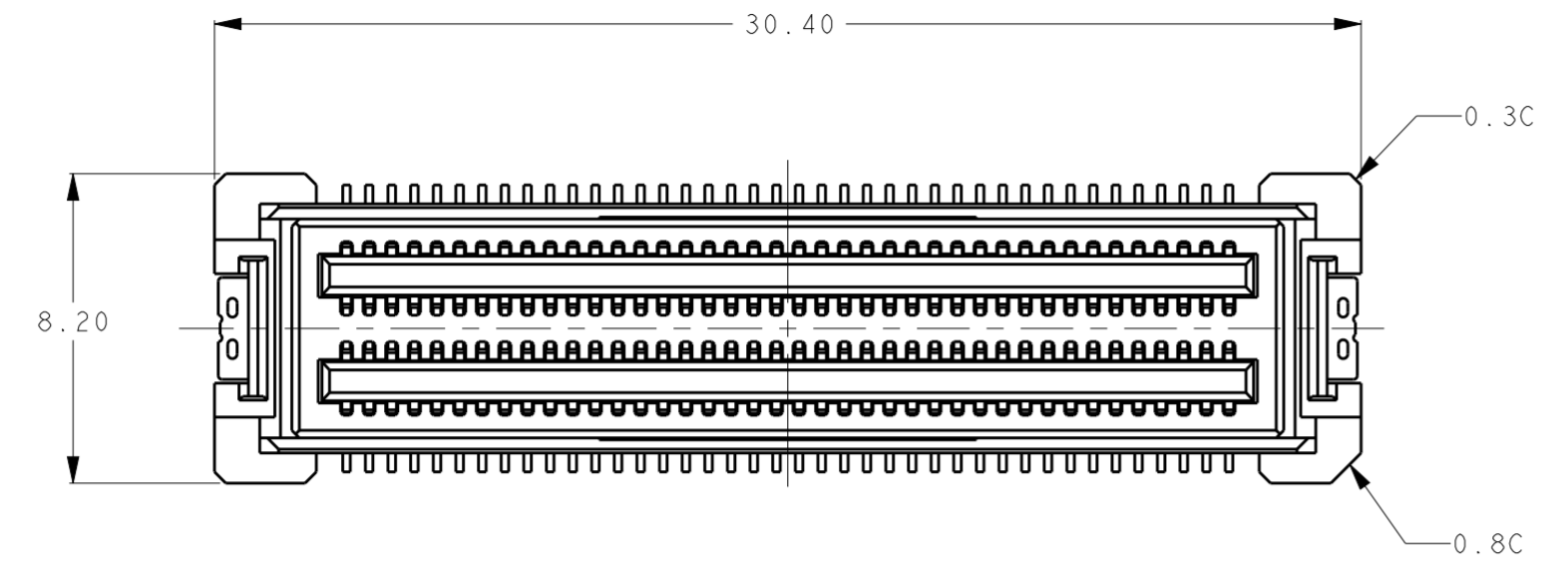

6376610-1:AS SHOWN

RECOMMENDED PCB LAYOUT

- 1 MATERIAL : HOUSING; LCP  
; CONTACT; COPPER ALLOY
- 2 FINISH : UNDER Ni PL. 0.8μmMIN  
CONTACT AREA: Au PL. 0.3μmMIN  
SOLDERING AREA: Au FLASH
- 3. COPLANARITY 0.1MAX.
- 4. SHOULD BE PUT 45 CONNECTORS IN HARD TRAY. (SEE SHEET 2)
- 5 DATE CODE IS MARKED TO CHINA PRODUCTION PRODUCT.  
THE FACE SIDE AND BACK SIDE IS NOT ASKED.
- 6 AMP : MADE IN JAPAN  
AMP : MADE IN CHINA
- 7 CONNECTORS AND TRAY SHALL BE COVERED BY PLASTIC BAG  
WITH ENCLOSED DESICCANT.

DESCRIPTION	PACKAGE	PART NO
WITH POLYIMIDE TAPE	HARD TRAY	6376610-2
W/O POLYIMIDE TAPE	HARD TRAY	6376610-3
W/O POLYIMIDE TAPE	HARD TRAY	6376610-1

THIS DRAWING IS A CONTROLLED DOCUMENT FOR TYCO ELECTRONICS CORPORATION IT IS SUBJECT TO CHANGE AND THE CONTROLLING ENGINEERING ORGANIZATION SHOULD BE CONTACTED FOR THE LATEST REVISION.		DWN K.Sakai 23JAN2006 CHK E.Takemasa 23JAN2006 APVD M.Kimura 23JAN2006	Tyco Electronics Corporation Kawasaki, Japan
DIMENSIONS: mm 	TOLERANCES UNLESS OTHERWISE SPECIFIED: 0 PLC ±0.3 1 PLC ±0.25 2 PLC ±0.2 3 PLC ± 4 PLC ± ANGLES ±3° FINISH	PRODUCT SPEC 108-5724 APPLICATION SPEC -	NAME HDR ASSEMBLY 9mm HEIGHT 0.6mm PITCH 80P MICRO STACK CONNECTOR
MATERIAL 1 SEE NOTE 2 SEE NOTE	WEIGHT 2.1g	SIZE A20779	DRAWING NO C-6376610
CUSTOMER DRAWING		SCALE 1:1	SHEET 1 OF 2 REV FI

THIS DRAWING IS UNPUBLISHED. RELEASED FOR PUBLICATION 20  
 © COPYRIGHT 20 BY TYCO ELECTRONICS CORPORATION. ALL INTERNATIONAL RIGHTS RESERVED.

LOC	DIST	REVISIONS					
J	-	P	LTR	DESCRIPTION	DATE	DWN	APVD
		-		SEE SHEET 1	-	-	-

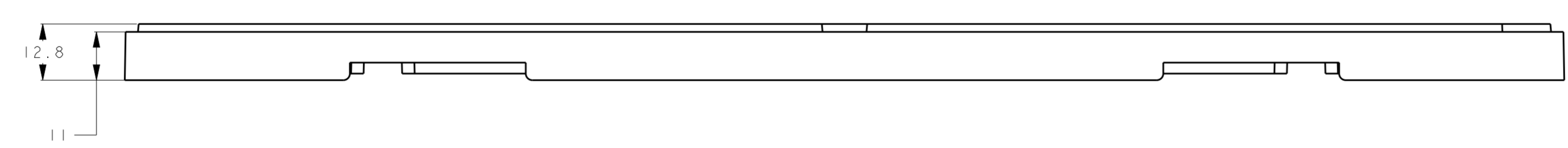
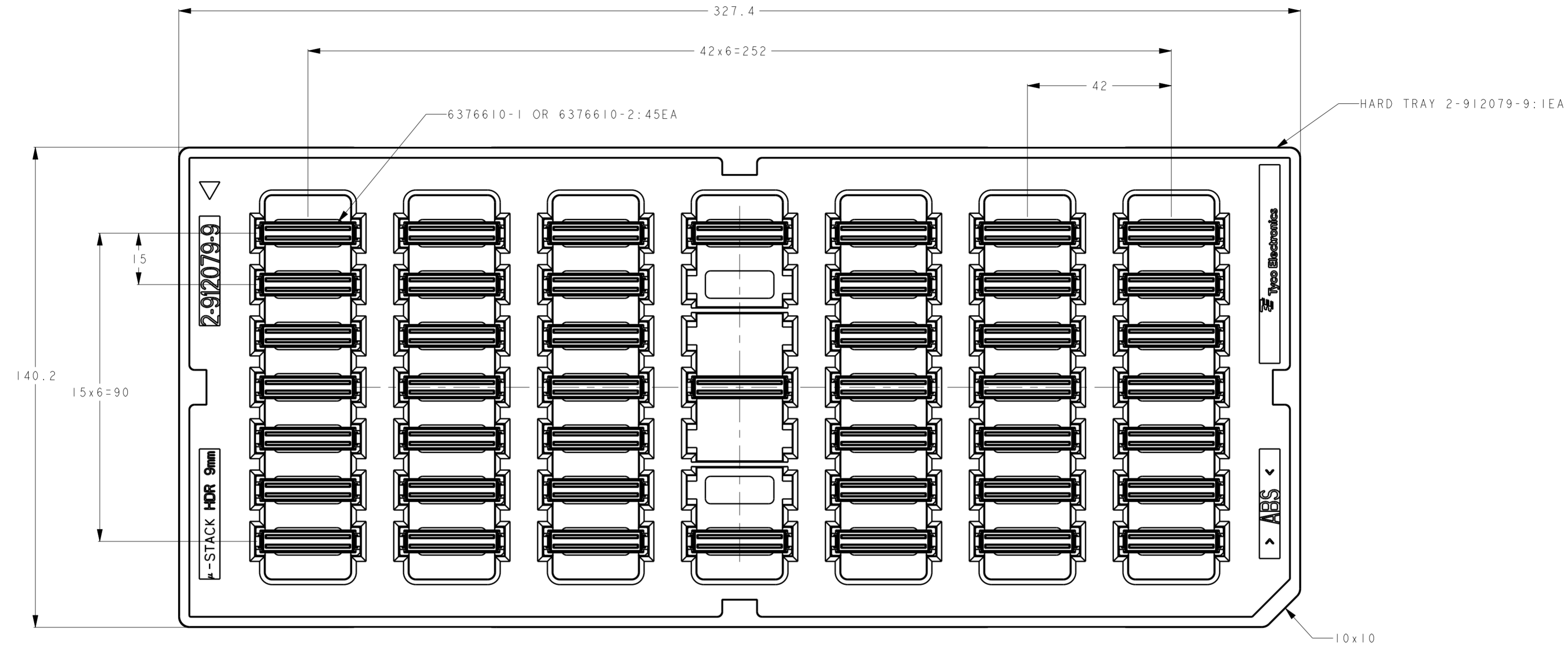

HARD TRAY ASSEMBLY SPEC

THIS DRAWING IS A CONTROLLED DOCUMENT FOR TYCO ELECTRONICS CORPORATION IT IS SUBJECT TO CHANGE AND THE CONTROLLING ENGINEERING ORGANIZATION SHOULD BE CONTACTED FOR THE LATEST REVISION.		DWN K. Sakai 23JAN2006 CHK E. Takemasa 23JAN2006 APVD M. Kimura 23JAN2006	Tyco Electronics Corporation Kawasaki, Japan
DIMENSIONS: □□: □ (mm)	TOLERANCES UNLESS OTHERWISE SPECIFIED: □□□□ ± 1 0-PLC ± 0.3 1-PLC ± 0.25 2-PLC ± 0.2 3-PLC ± 4-PLC ± ANGLES ± 3° FINISH □□	PRODUCT SPEC 108-5724 APPLICATION SPEC - WEIGHT 2.1g	NAME HDR ASSEMBLY 9mm HEIGHT 0.6mm PITCH 80P MICRO STACK CONNECTOR
MATERIAL		SIZE A20779 CAGE CODE C-6376610 DRAWING NO.	RESTRICTED TO
CUSTOMER DRAWING		SHEET 2 OF 2	REV F1