

66597-1 ✓ ACTIVE

AMP | AMP Type III+

TE Internal #: 66597-1

Power Contacts, Contact, Precious Metal, 18 – 14 AWG Wire Size, .8 – 2 mm² Wire Size, Wire & Cable, Crimp, Power & Signal, Pin, AMP Type III+

[View on TE.com >](#)



Connectors > Power Connectors > Power Contacts



Power Contact Type: **Contact**

Contact Mating Area Plating Material: **Precious Metal**

Wire Size: **.8 – 2 mm²**

Connector & Contact Terminates To: **Wire & Cable**

Features

Product Type Features

Power Contact Type	Contact
Connector & Contact Terminates To	Wire & Cable

Electrical Characteristics

Test Current	13 A
--------------	------

Contact Features

Contact Mating Area Plating Material	Precious Metal
Contact Current Rating (Max)	13 A
Contact Type	Pin
Contact Retention Within Housing	With
Mating Pin Diameter	1.57 mm[.062 in]
Contact Base Material	Brass
Contact Mating Area Plating Material Thickness	2.54 µm[100 µin]
Wire Contact Termination Area Plating Thickness	2.54 µm[100 µin]
Wire Contact Termination Area Plating Material	Tin-Lead
Wire Contact Termination Area Plating Material Finish	Bright
Contact Orientation	Straight
Contact Underplating Material	Nickel
Contact Underplating Material Thickness	1.27 µm[50 µin]
Contact Size	16



Termination Features

Termination Method to Wire & Cable	Crimp
------------------------------------	-------

Mechanical Attachment

Wire Insulation Support	With
-------------------------	------

Dimensions

Wire Size	.8 – 2 mm ²
Accepts Wire Insulation Diameter Range	2.79 – 3.81 mm [.11 – .15 in]

Usage Conditions

Operating Temperature Range	-55 – 150 °C [-67 – 302 °F]
-----------------------------	-----------------------------

Operation/Application

Circuit Application	Power & Signal
---------------------	----------------

Packaging Features

Packaging Method	Reel
Packaging Quantity	4000

Other

Wire/Cable Type	Discrete Wire
For Use With	CPC Connectors, M Series Connectors
Comment	Contacts can only be used in Metrimate, Series 1 (Arr. 23-24), Series 4 (Arr. 23-13M, 23-16M, 23-22M), and VDE connectors.

Product Compliance

[For compliance documentation, visit the product page on TE.com>](#)

EU RoHS Directive 2011/65/EU	Not Compliant
EU ELV Directive 2000/53/EC	Not Compliant
China RoHS 2 Directive MIIT Order No 32, 2016	Restricted Materials Above Threshold
EU REACH Regulation (EC) No. 1907/2006	Current ECHA Candidate List: JUNE 2022 (224) Candidate List Declared Against: JAN 2022 (223) SVHC > Threshold: Pb (13% in Component Part) Article Safe Usage Statements: Do not eat, drink or smoke when using this product. Wash thoroughly after handling. Recycle if possible and dispose of the article by following all applicable governmental regulations relevant to your geographic location.
Halogen Content	Low Halogen - Br, Cl, F, I < 900 ppm per homogenous material. Also BFR/CFR/PVC

Free

Solder Process Capability

Not applicable for solder process capability

Product Compliance Disclaimer

This information is provided based on reasonable inquiry of our suppliers and represents our current actual knowledge based on the information they provided. This information is subject to change. The part numbers that TE has identified as EU RoHS compliant have a maximum concentration of 0.1% by weight in homogenous materials for lead, hexavalent chromium, mercury, PBB, PBDE, DBP, BBP, DEHP, DIBP, and 0.01% for cadmium, or qualify for an exemption to these limits as defined in the Annexes of Directive 2011/65/EU (RoHS2). Finished electrical and electronic equipment products will be CE marked as required by Directive 2011/65/EU. Components may not be CE marked. Additionally, the part numbers that TE has identified as EU ELV compliant have a maximum concentration of 0.1% by weight in homogenous materials for lead, hexavalent chromium, and mercury, and 0.01% for cadmium, or qualify for an exemption to these limits as defined in the Annexes of Directive 2000/53/EC (ELV). Regarding the REACH Regulation, the information TE provides on SVHC in articles for this part number is based on the latest European Chemicals Agency (ECHA) 'Guidance on requirements for substances in articles' posted at this URL: <https://echa.europa.eu/guidance-documents/guidance-on-reach>

Compatible Parts

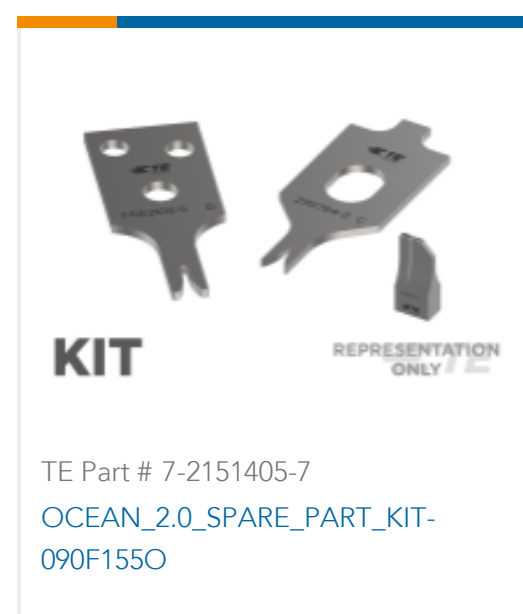
Also in the Series | **AMP Type III+**



Insertion & Extraction Tools(4)

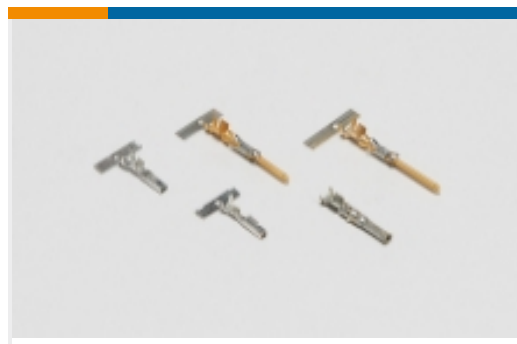

Power Contacts(414)

Customers Also Bought

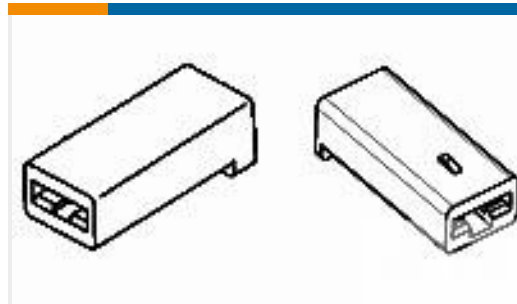
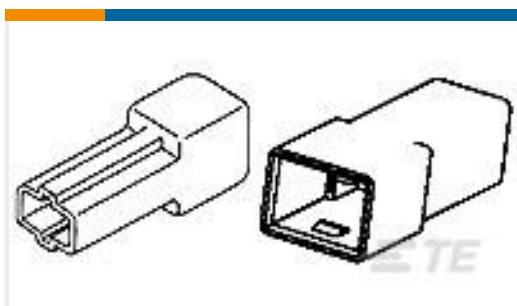
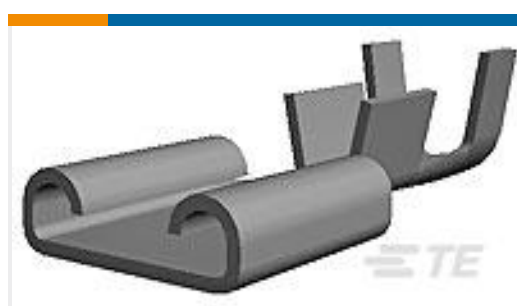
TE Part #207153-1
6 POS SQ GRID METRIMATE-RCPTTE Part #480054-3
FF 250 REC HSG 1P NYLON NATTE Part #60249-2
FF 250 REC 16-12AWG TPBRTE Part #1587828-3
INNER FERRULE, SIZE C, HVA280-2PITE Part #480053-3
FF 250 TAB HSG 1P NYLON NATTE Part #61624-1
RING CRIMP 16-12 AWG BRTE Part #2103181-3
CABLE SEAL RTNR, SIZE C, HVA280-2PI XETE Part #1587829-3
OUTER FERRULE, SIZE C, HVA280-2PITE Part #350078-1
CMNL SOK 30-22 PTPBRTE Part #62428-2
250 FASTON REC 12-10 AWG TPBR

Documents

Product Drawings

III+ PIN,18-14,TIN-LEAD,STRIP

English

CAD Files

Customer View Model

ENG_CVM_CVM_66597-1_AA.2d_dxf.zip

English

3D PDF



3D

Customer View Model

[ENG_CVM_CVM_66597-1_AA.3d_igs.zip](#)

English

Customer View Model

[ENG_CVM_CVM_66597-1_AA.3d_stp.zip](#)

English

By downloading the CAD file I accept and agree to the [Terms and Conditions](#) of use.

Product Specifications

[Application Specification](#)

English

Product Environmental Compliance

[MD_66597-1_090820112249](#)

English

[MD_66597-1_090820112249](#)

English

Instruction Sheets

[Instruction Sheet \(U.S.\)](#)

Japanese

[Instruction Sheet \(U.S.\)](#)

English

Agency Approvals

[Agency Approval Document](#)

English