

## AMPLIVAR

TE Internal #: 62002-2

Splices, 12 – 9 AWG Wire Size, 3.46 – 6.38 mm<sup>2</sup> Wire Size, Splice

Capacity 3, 7000 – 13000 CMA Wire Size, Brass, Pigtail Splice

Splice, AMPLIVAR

[View on TE.com >](#)

Terminals &amp; Splices &gt; Splices

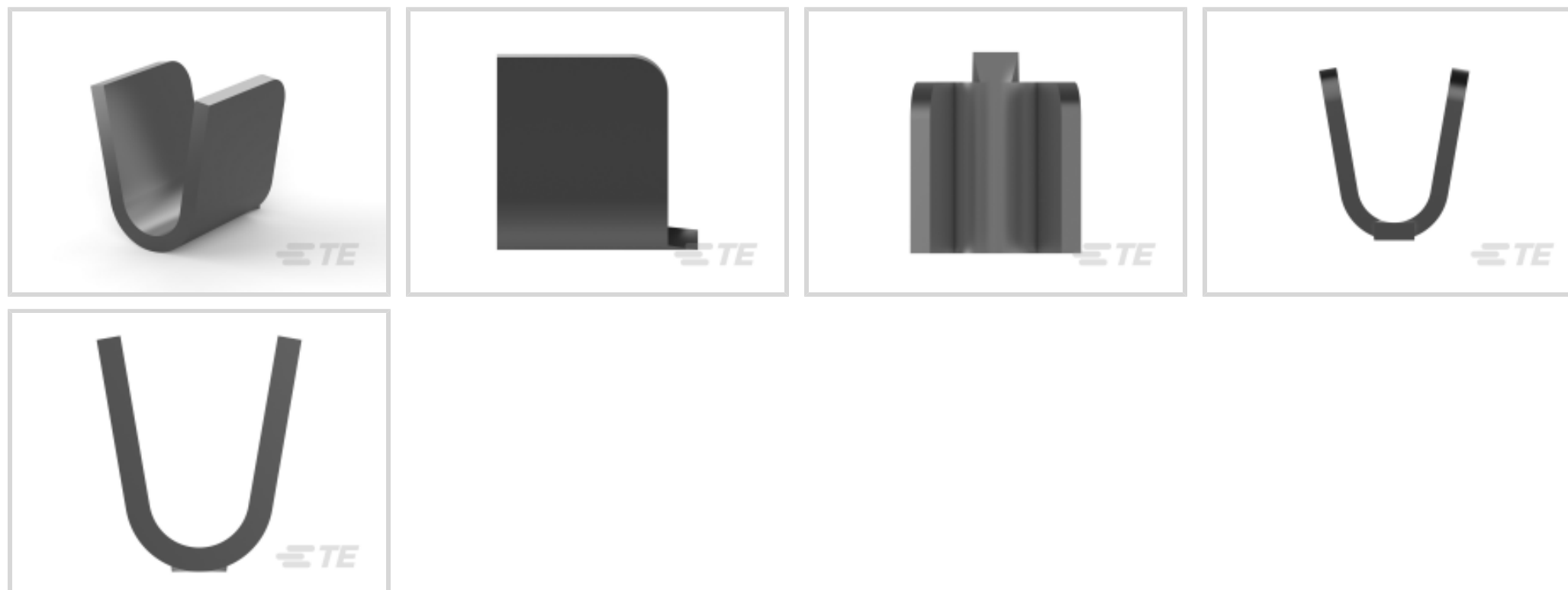

Wire Size: 7000 – 13000 CMA

Sealable: No

Splice Capacity: 3

## Features

## Product Type Features

Sealable	No
Splice Type	Pigtail Splice
Serrated	Yes
Compatible With Discrete Wire Type	Magnet Wire, Solid

## Configuration Features

Strip Orientation	End Feed
Splice Capacity	3
Number of Serrations	7

## Electrical Characteristics

Operating Voltage	250 V
-------------------	-------

## Body Features

Weight per Piece	.453 g
Plating Material	Tin
Primary Product Material	Brass

## Contact Features



Contact Plating Material	Tin
--------------------------	-----

Barrel Type	Open
-------------	------

### Termination Features

Crimp Width	4.57 mm [.18 in]
-------------	------------------

### Mechanical Attachment

Wire Insulation Support	Without
-------------------------	---------

### Dimensions

Wire Size	7000 – 13000 CMA
-----------	------------------

Terminal Material Thickness	.64 mm [.025 in]
-----------------------------	------------------

Overall Product Length	5.72 mm [.225 in]
------------------------	-------------------

### Usage Conditions

Insulation Option	Uninsulated
-------------------	-------------

Operating Temperature Range	-65 – 150 °C [-85 – 302 °F]
-----------------------------	-----------------------------

### Operation/Application

Heavy Duty	No
------------	----

Compatible With Wire Base Material	Aluminum, Copper
------------------------------------	------------------

### Industry Standards

Government Qualified Splice	No
-----------------------------	----

### Packaging Features

Packaging Quantity	12500
--------------------	-------

Packaging Method	Strip
------------------	-------

### Product Compliance

[For compliance documentation, visit the product page on TE.com>](#)

EU RoHS Directive 2011/65/EU	Compliant
------------------------------	-----------

EU ELV Directive 2000/53/EC	Compliant
-----------------------------	-----------

China RoHS 2 Directive MIIT Order No 32, 2016	No Restricted Materials Above Threshold
---	---

EU REACH Regulation (EC) No. 1907/2006	Current ECHA Candidate List: JUNE 2022 (224) Candidate List Declared Against: JAN 2022 (223) SVHC > Threshold: Not Yet Reviewed
--	--

Halogen Content	Low Halogen - Br, Cl, F, I < 900 ppm per
-----------------	--

homogenous material. Also BFR/CFR/PVC Free

Solder Process Capability

Not applicable for solder process capability

#### Product Compliance Disclaimer

This information is provided based on reasonable inquiry of our suppliers and represents our current actual knowledge based on the information they provided. This information is subject to change. The part numbers that TE has identified as EU RoHS compliant have a maximum concentration of 0.1% by weight in homogenous materials for lead, hexavalent chromium, mercury, PBB, PBDE, DBP, BBP, DEHP, DIBP, and 0.01% for cadmium, or qualify for an exemption to these limits as defined in the Annexes of Directive 2011/65/EU (RoHS2). Finished electrical and electronic equipment products will be CE marked as required by Directive 2011/65/EU. Components may not be CE marked. Additionally, the part numbers that TE has identified as EU ELV compliant have a maximum concentration of 0.1% by weight in homogenous materials for lead, hexavalent chromium, and mercury, and 0.01% for cadmium, or qualify for an exemption to these limits as defined in the Annexes of Directive 2000/53/EC (ELV). Regarding the REACH Regulation, the information TE provides on SVHC in articles for this part number is based on the latest European Chemicals Agency (ECHA) 'Guidance on requirements for substances in articles' posted at this URL: <https://echa.europa.eu/guidance-documents/guidance-on-reach>

## Compatible Parts



Also in the Series | **AMPLIVAR**



Crimp Wire Pins, Tabs & Ferrules(5)



Magnet Wire Terminals(5)



PCB Terminals(1)



Quick Disconnects(42)



Ring Terminals & Spade Terminals(28)



Splices(78)

### Customers Also Bought



TE Part #41559  
RING 18-14 AWG BR

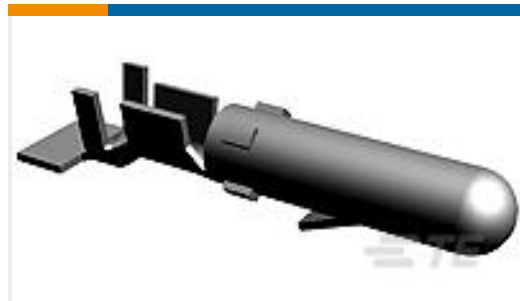

TE Part #61086-1  
.156 MNL PIN 20-14 PTPBR



TE Part #794096-1  
06P UMNL PLUG

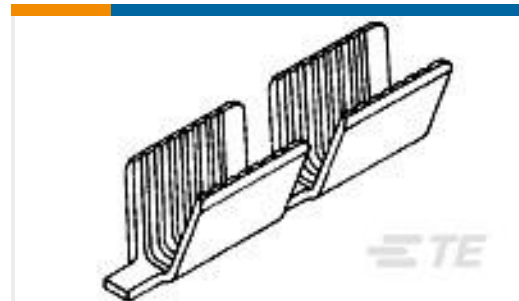

TE Part #62040-1  
SPLC AMVAR 1500-5000 020TPBR

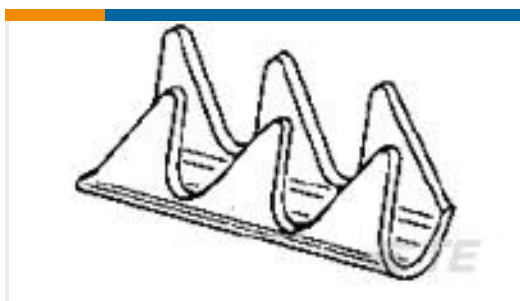

TE Part #926933-2  
WIRE PIN 18-17 AWG .01 BR

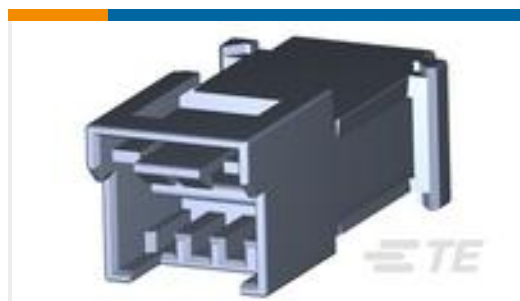

TE Part #1718044-4  
RAST2.5 W2W Crimp-IDC 2pos Motor Mnt

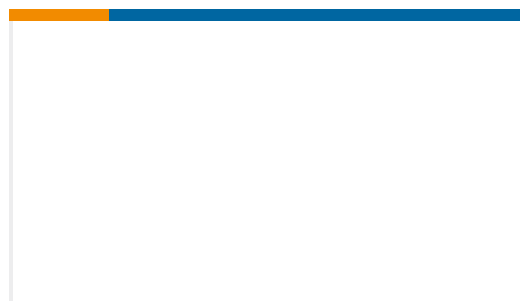

TE Part #659822-1  
INSERTER,SINGLE

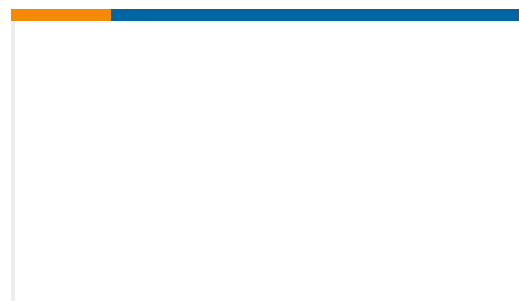

TE Part #659304-1  
SHEAR BLADE, UPPER



TE Part #2844970-1  
DETENT PIN

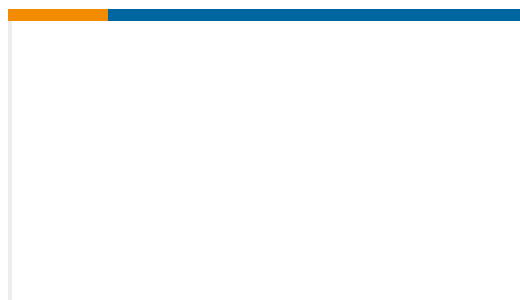

TE Part #659307-1  
SHEAR BLADE, LOWER

### Documents



### Product Drawings

[SPLC AMVAR 7000-13000 025TPBR](#)

English

---

### CAD Files

[3D PDF](#)

3D

Customer View Model

[ENG\\_CVM\\_CVM\\_62002-2\\_W\\_c-62002-2-w.2d\\_dxf.zip](#)

English

Customer View Model

[ENG\\_CVM\\_CVM\\_62002-2\\_W\\_c-62002-2-w.3d\\_igs.zip](#)

English

Customer View Model

[ENG\\_CVM\\_CVM\\_62002-2\\_W\\_c-62002-2-w.3d\\_stp.zip](#)

English

By downloading the CAD file I accept and agree to the [Terms and Conditions](#) of use.

---

### Datasheets & Catalog Pages

[1654742\\_HOUSEHOLD\\_APPLIANCES\\_RAST5](#)

English

[Magnet Wire Terminals & Splices](#)

English

---

### Product Specifications

[Application Specification](#)

English

[AMPLIVAR 7 Serration Pigtail Splice](#)

English

---

### Product Environmental Compliance

[MD\\_62002-2\\_11192014944\\_dmtec](#)

English

[MD\\_62002-2\\_11192014944\\_dmtec](#)

English