

| LOC | DIST | P | F | ZONE | LTR | DESCRIPTION | DATE | APPD |
|-----|------|---|---|------|-----|----------------------|--------|-------|
| AF | 50 | | | | | REV PER 0L10-0149-96 | 2NOV96 | RG/KR |

- 1 CONTINUOUS STRIP ON REELS WITH TERMINALS LOCATED ON 5.59±0.08 [.220±.003] CENTERS.
- 2 SLOT TERMINATES EITHER A SINGLE OR DOUBLE MAGNET WIRES OF THE SAME TYPE AND SIZE, COPPER RANGE: 0.23-0.32mm [#31-#28] AWG.
- 3 0.002032 [.000080] MIN TIN PER MIL-T-10727 OVER 0.00127 [.000050] MIN NICKEL QQ-N-290

IDENTIFICATION NUMBER 5 FOR MAGNET WIRE RANGE

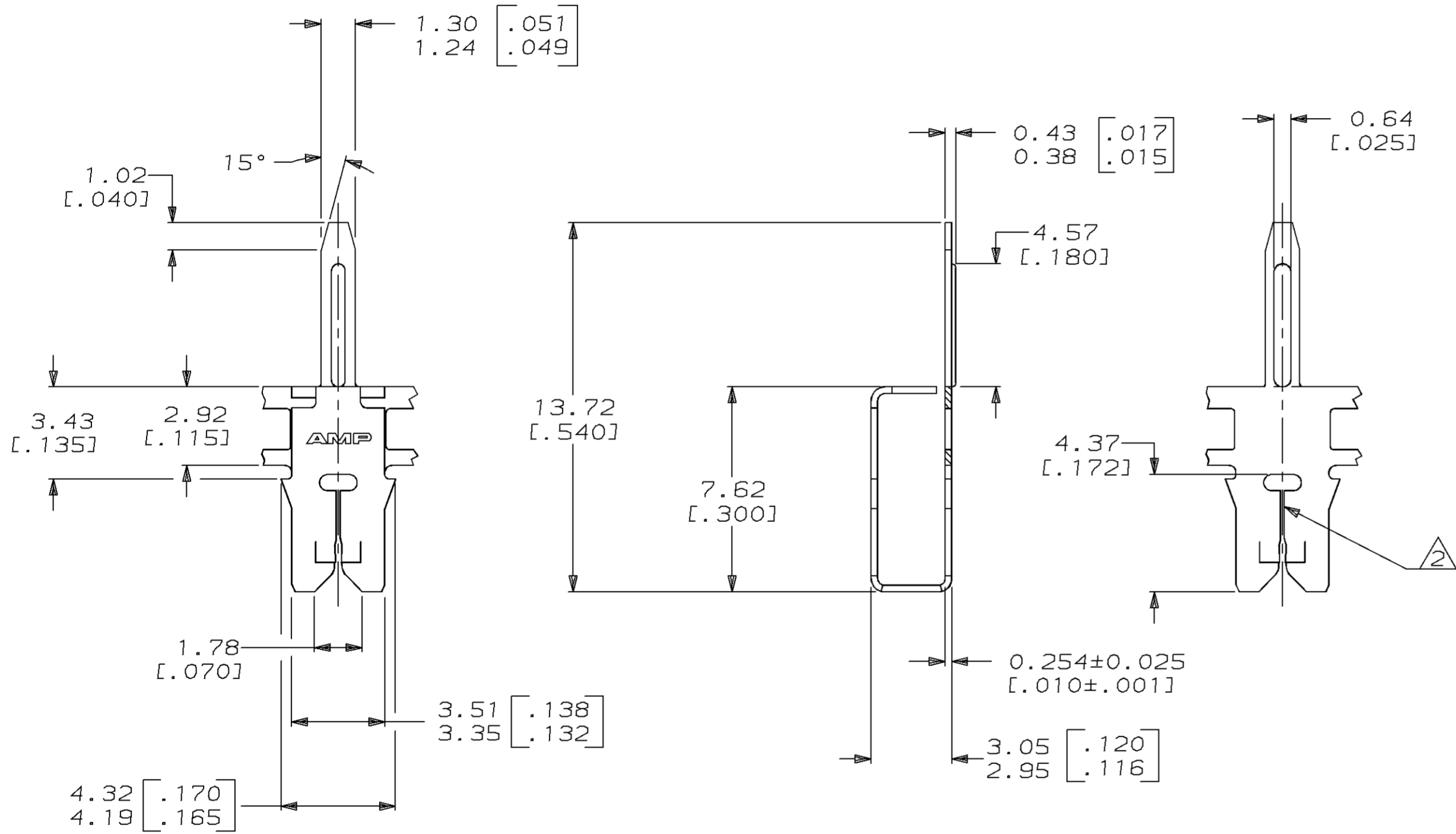
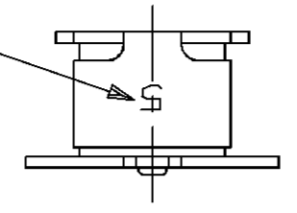

62928-1

PART NO

| | | | | | |
|------------------------------------------------------------------------------------------------------------------------------------------|--|------------------------------------|--|-----------------------------------------------|--------------------|
| DO NOT SCALE PRINT. UNLESS SPECIFIED DIMENSIONS IN mm [INCHES] TOLERANCES ON : 2 PLC DEC ± 0.25 [.010] 3 PLC DEC ± - ANGLES ± - | | DR 11/JUL/94 MICHAEL S. FEHER | | AMP Incorporated Harrisburg, PA 17105-3608 | |
| MATERIAL 4M BRASS | | CHK 12/JUL/94 JEFF R. RUTH | | | |
| FINISH 3 | | APPD 12/JUL/94 NELSON E. NEFF | | NAME POST, TERMINAL, MAG-MATE | |
| | | APPD 12/JUL/94 TERRY L. SHUTTER | | PRODUCT SPEC 108-2012 | |
| | | APPLICATION SPEC 114-2046 | | SIZE C | CAGE CODE 00779 |
| | | WEIGHT - | | DRAWING NO G=62928 | SCALE 6:1 |
| | | | | SHEET 1 OF 1 | |

THIS DRAWING IS A CONTROLLED DOCUMENT FOR AMP INCORPORATED. IT IS SUBJECT TO CHANGE AND THE CONTROLLING ENGINEERING ORGANIZATION SHOULD BE CONTACTED FOR THE LATEST REVISION.