

FEATURES AND SPECIFICATIONS

Features and Benefits

- Long tab-style terminal provides low insertion force and secure contact
- Locking tang provides guide for retainer

Reference Information

Packaging: Reel or bag

Use With: [51139](#)

Designed In: Millimeters

Electrical

Voltage: 600V

Current: 9.0A

Physical

Contact: Copper Alloy

Plating: Tin

Wire Range:

50599—16 to 22 AWG

50600—20 to 26 AWG

Insulation Range:

50599—2.00 to 3.40mm dia.

Note: When using retainer—2.50mm dia. max.

50600—1.25 to 2.35mm dia.

Strip Length: 2.70 to 3.30mm

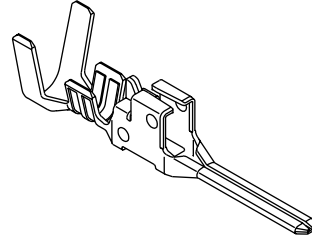
**3.96mm (.156") Pitch
Wire-to-Wire
Crimp Terminal**
50599/50600**Male**

CATALOG DRAWING (FOR REFERENCE ONLY)

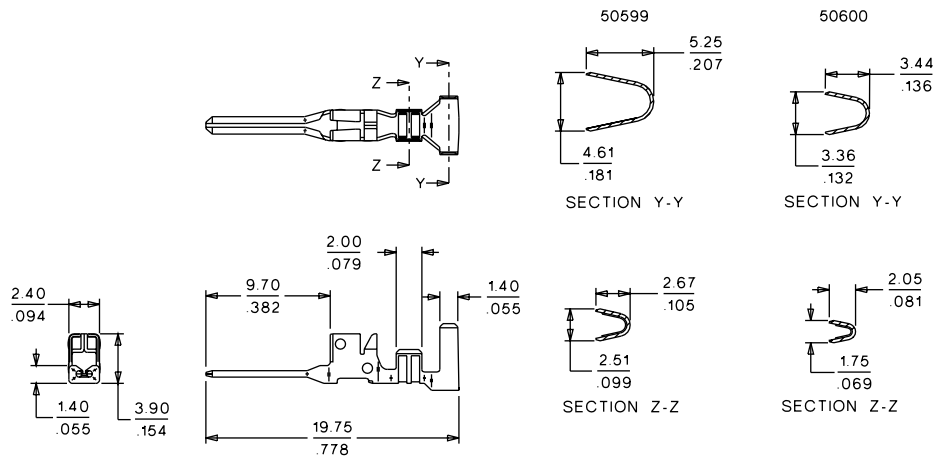

ORDERING INFORMATION

Order No.	Terminal
50599-8000	Reel
50600-8000	
50599-8100	Bag
50600-8100	