

Product-number	Plating Performance Level	Application
52057-102	TELCORDIA CO	Standard
52057-102LF	TELCORDIA CO	Lead Free
52057-302	Customer Special	Standard
52057-302LF	Customer Special	Lead Free

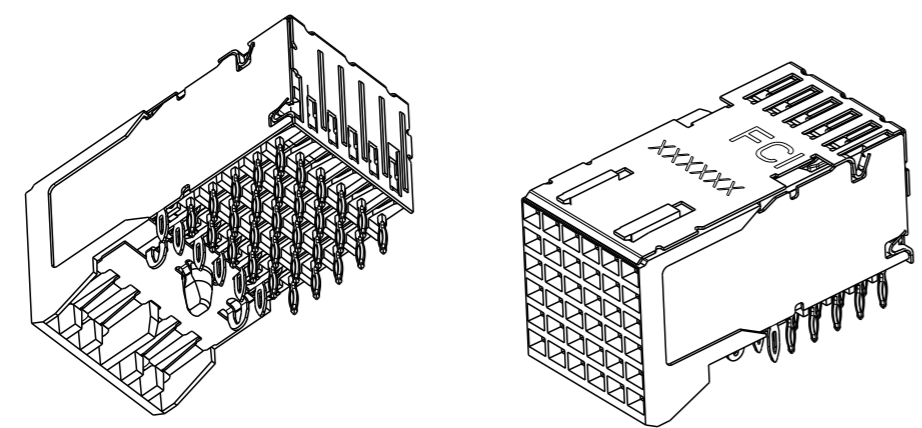

spec ref	-	dr	P-Mathew Nebu	2011/05/20	projection	mm	size	A3	scale	5:1		
tolerance std	ISO 406 ISO 1101	eng	Stalin Alosius	2014/06/24			ecn no	ELX-17993-1	rel level	Released		
TOLERANCES UNLESS OTHERWISE SPECIFIED		chr	-	2014/06/24							product family	Metral 4000
surface	ISO 1302	linear	0.X	±0.3		title 5x6 Receptacle Signal Assembly	dwg no 52057C	rev K	Product - Customer Drw			
		angular	0°	±2°					cat. no.	www.fci.com	sheet 1 of 3	

	Signal PTH Details				Vertical Shield PTH Details			
	SnPb Finish	Sn Finish	Cu Finish	Immersion Ag Finish	SnPb Finish	Sn Finish	Cu Finish	Immersion Ag Finish
Drilled Hole	0.58 - 0.62 mm	0.58 - 0.62 mm	0.58 - 0.62 mm	0.58 - 0.62 mm	0.81 - 0.86 mm	0.81 - 0.86 mm	0.81 - 0.86 mm	0.81 - 0.86 mm
Copper Plating	25 - 50 μ m	25 - 50 μ m	25 - 50 μ m	25 - 50 μ m	25 μ m MIN	25 μ m MIN	25 μ m MIN	25 μ m MIN
SnPb Plating	5 - 15 μ m	-----	-----	-----	5 - 15 μ m	-----	-----	-----
Sn Plating	-----	0.8 - 1.2 μ m	-----	-----	-----	0.8 - 1.2 μ m	-----	-----
Immersion Ag plating	-----	-----	-----	0.2 - 0.6 μ m	-----	-----	-----	0.2 - 0.6 μ m
Finished Hole Dia	0.45 - 0.55 mm	0.46 - 0.55 mm	0.48 - 0.57 mm	0.48 - 0.57 mm	0.65 - 0.80 mm	0.65 - 0.80 mm	0.71 - 0.81 mm	0.71 - 0.81 mm

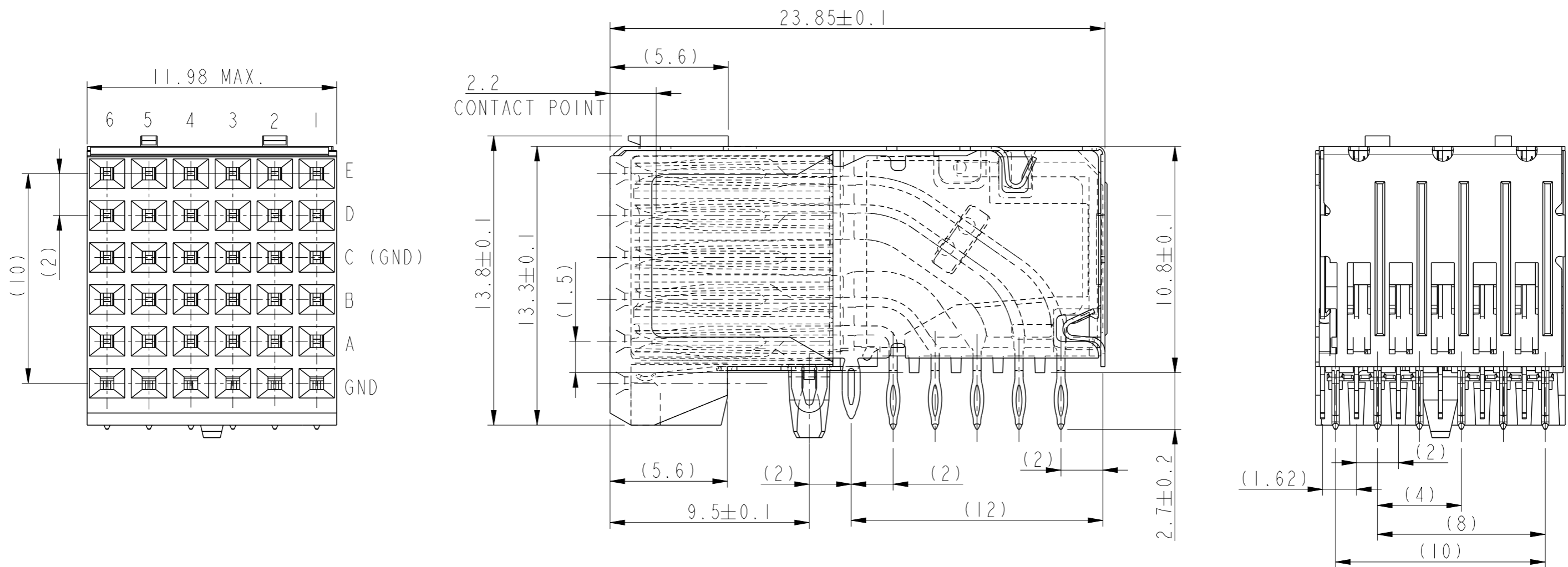
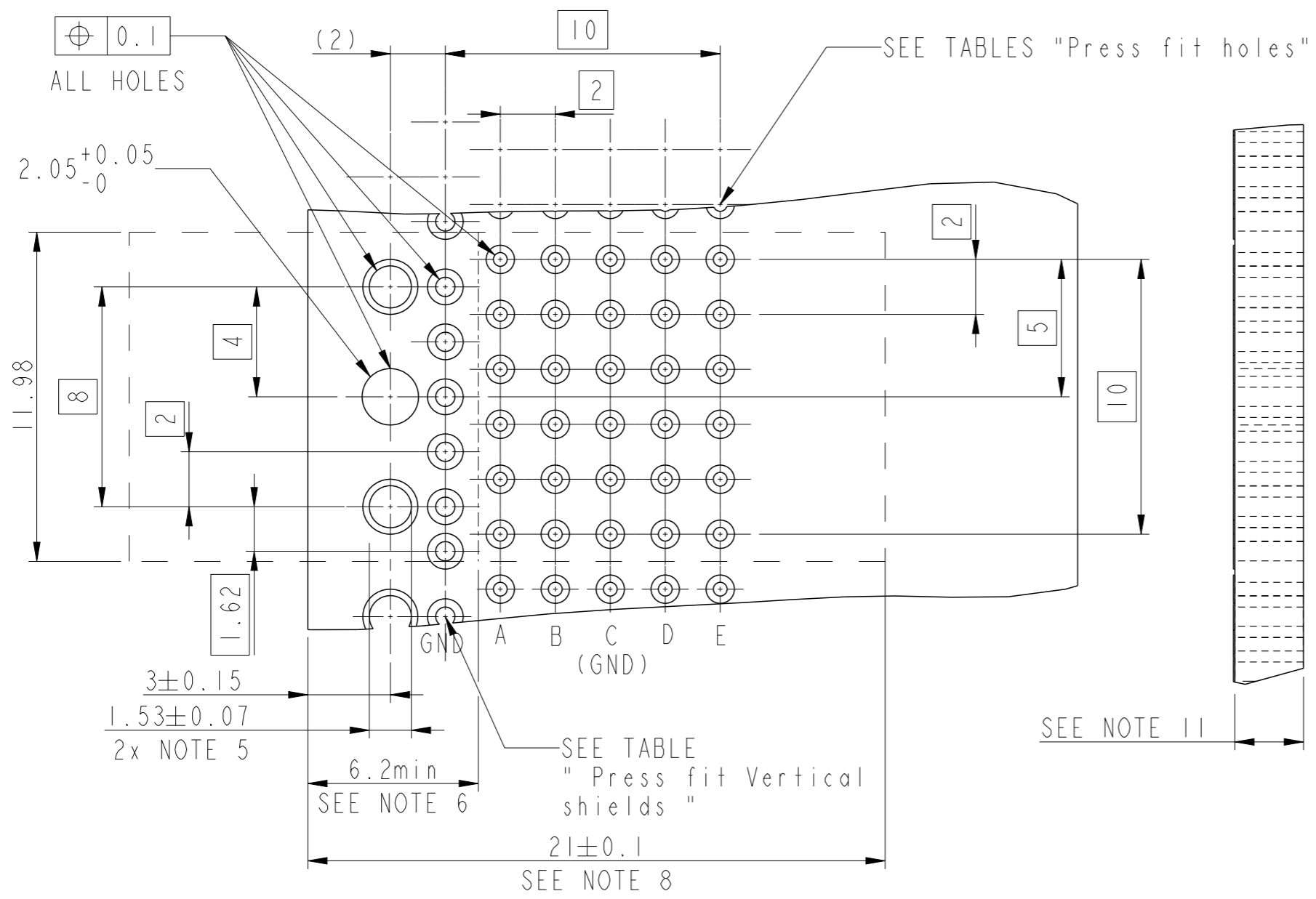

RECOMMENDED PCB HOLE PATTERN - COMPONENT SIDE

spec ref	-	dr	P-Mathew Nebu	2011/05/20	projection		size	A3	scale	5:1	
tolerance std	ISO 406 ISO 1101	eng	Stalin Alosius	2014/06/24	mm		ecn no	ELX-17993-1			
surface	✓	chr	-	-	product family	METRAL 4000	rel level	Released			
ISO 1302	linear	appr	K-Paul Biju	2014/06/24	5x6 Receptacle	Signal Assembly	dwg no	52057c		rev	K
	angular	www.fci.com	cat. no.	Product - Customer Drw	sheet 2 of 3						

Copyright FCI. FCI

NOTES:

1. BODY MATERIAL: LIQUID CRYSTAL POLYMER
30% GLASS FILLED
FLAME RETARDENT ACC. UL 94-V0
2. METAL PARTS: COPPER ALLOY
3. PLATING ON PRESS FIT AREA
52057-X02 IS SnPb
52057-X02LF IS Sn (LEAD FREE)
4. INDICATED HOLE IS UNPLATED.
5. 1.53 mm DIA HOLES (2) AT 8.00 CENTERS
ARE FOR GROUND
6. AVOID TRACES ON TOP OF BOARD DUE TO
EXPOSED GROUND SHIELD.
7. UNDERPLATING FOR SHIELDS AND SIGNAL
CONTACTS IS 1.3µm Ni MINIMUM.
8. COMPONENT KEEP OUT ZONE FOR PRESS BLOCK.
9. PRODUCT MARKING: DATE AND LOT CODE.
10. SEE GS-20-017 FOR APPLICATION TO PCB.
11. PCB THICKNESS 1.3 TO 2.5 mm
12. SEE PRODUCT SPECIFICATION GS-12-184 FOR
PRODUCT PERFORMANCE CHARACTERISTICS.
13. FOR LEAD FREE PART NUMBERS, ADD "LF" SUFFIX
14. THE PRODUCT (LF) MEETS EUROPEAN UNION DIRECTIVES
AND OTHER COUNTRY REGULATIONS AS DESCRIBED IN
GS-22-008

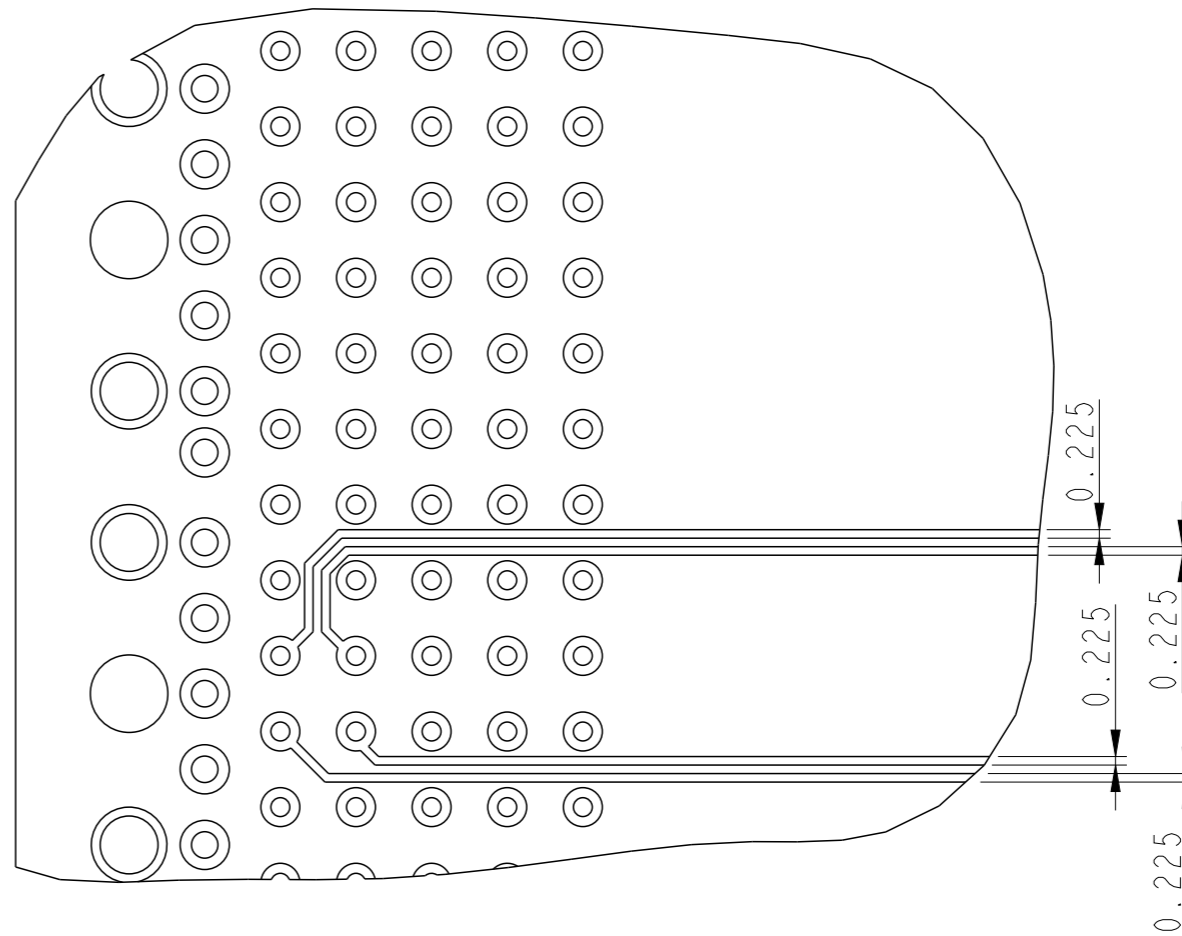

RECOMMENDED ROUTING AND TRACE DIMENSIONS
SCALE 5:1

spec ref -		dr P-Mathew Nebu	2011/05/20	projection	mm	size A3	scale 5:1
tolerance std ISO 406 ISO 1101		TOLERANCES UNLESS OTHERWISE SPECIFIED				ecn no ELX-17993-1	
		eng Stalin Alosius	2014/06/24			product family METRAL 4000	rel level Released
surface ✓	linear	0.X	±0.3		title 5x6 Receptacle Signal Assembly	dwg no 52057c	rev K
		0.XX	±0.1				
ISO 1302	angular	0°	±2°				



Copyright FCI.