

4
DRAWING MADE IN THIRD ANGLE PROJECTION

3

2

1

THIS DRAWING IS UNPUBLISHED. RELEASED FOR PUBLICATION .19
 © COPYRIGHT 19 BY AMP INCORPORATED. ALL INTERNATIONAL RIGHTS RESERVED.

LOC	DIST	P	F	ZONE	LTR	REVISIONS	DATE	APPD
AF	50				H	REACT PER 0G3A-0748-03	JR/PD	01DEC03

1 TO ENSURE PROPER MATING OF RECEPTACLE TO TAB, TAB LENGTH ON DOOR SWITCH SHOULD BE A MINIMUM OF 8.255 [.325].

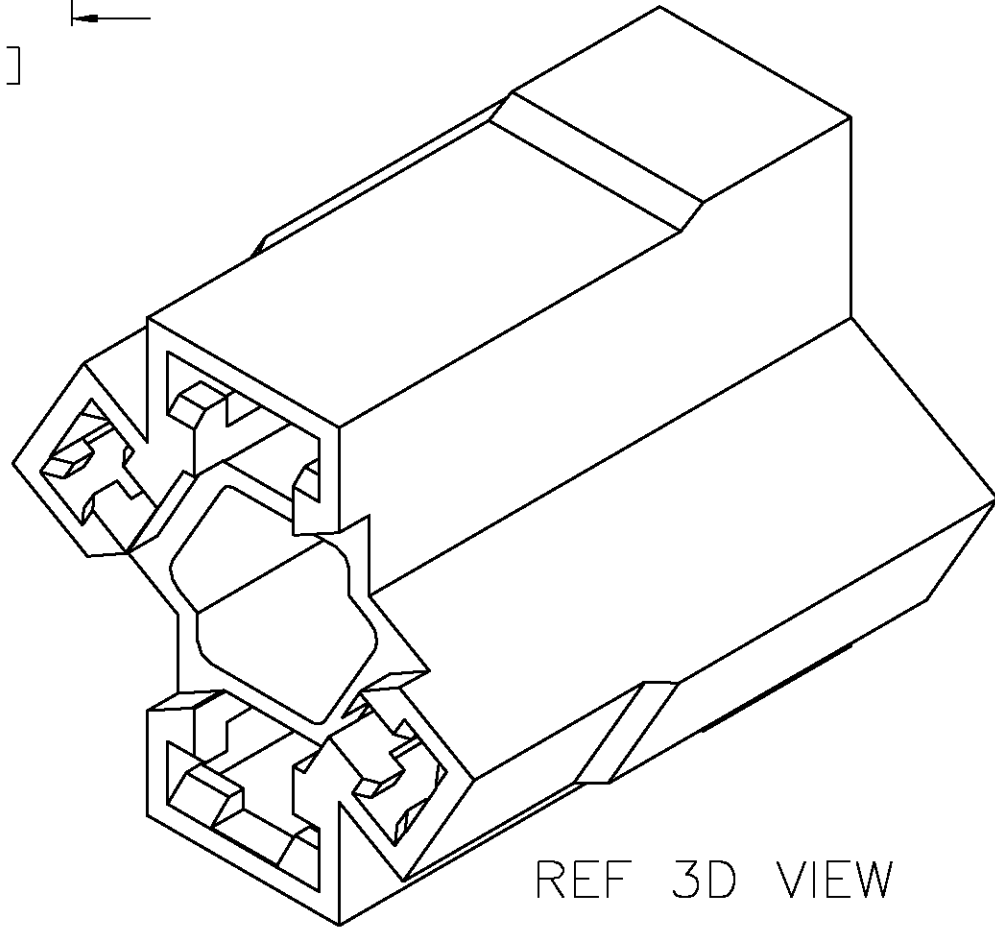
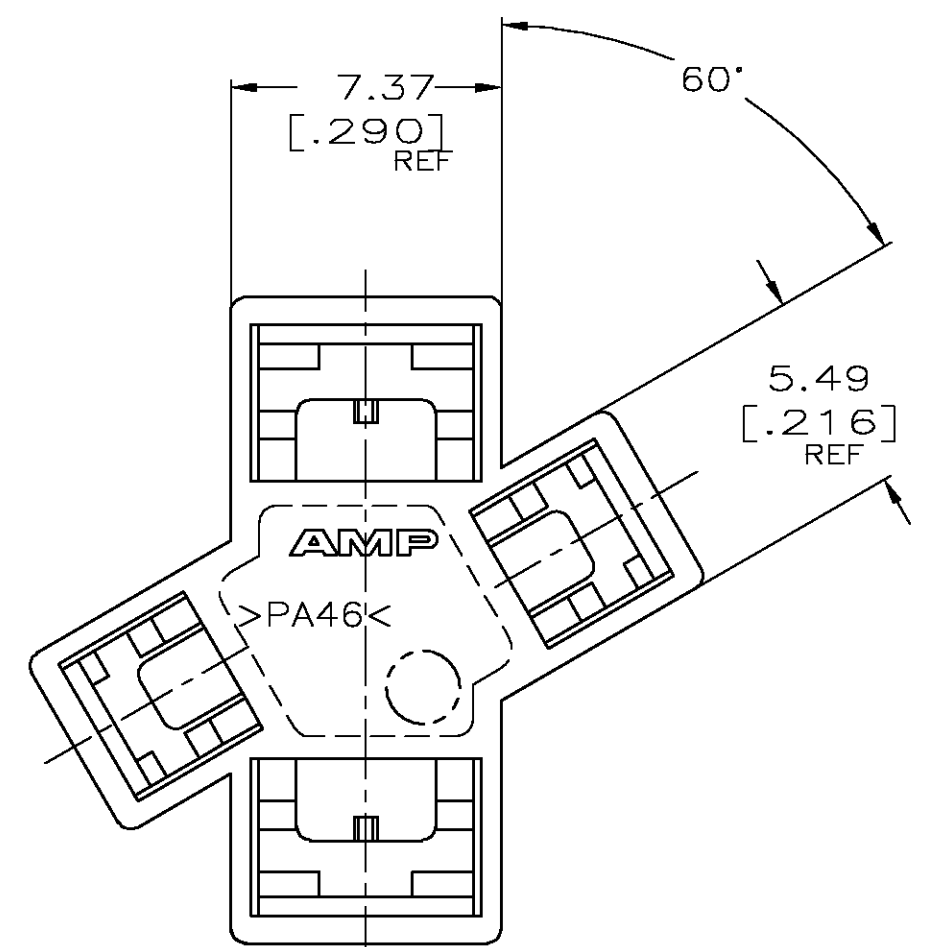
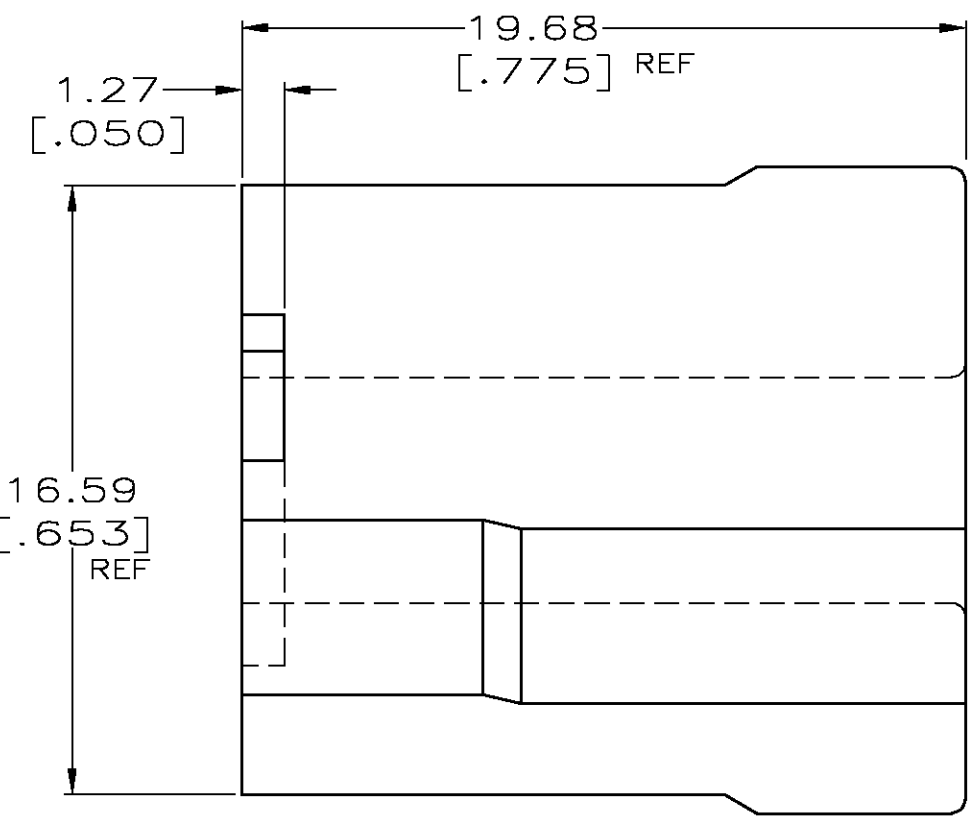
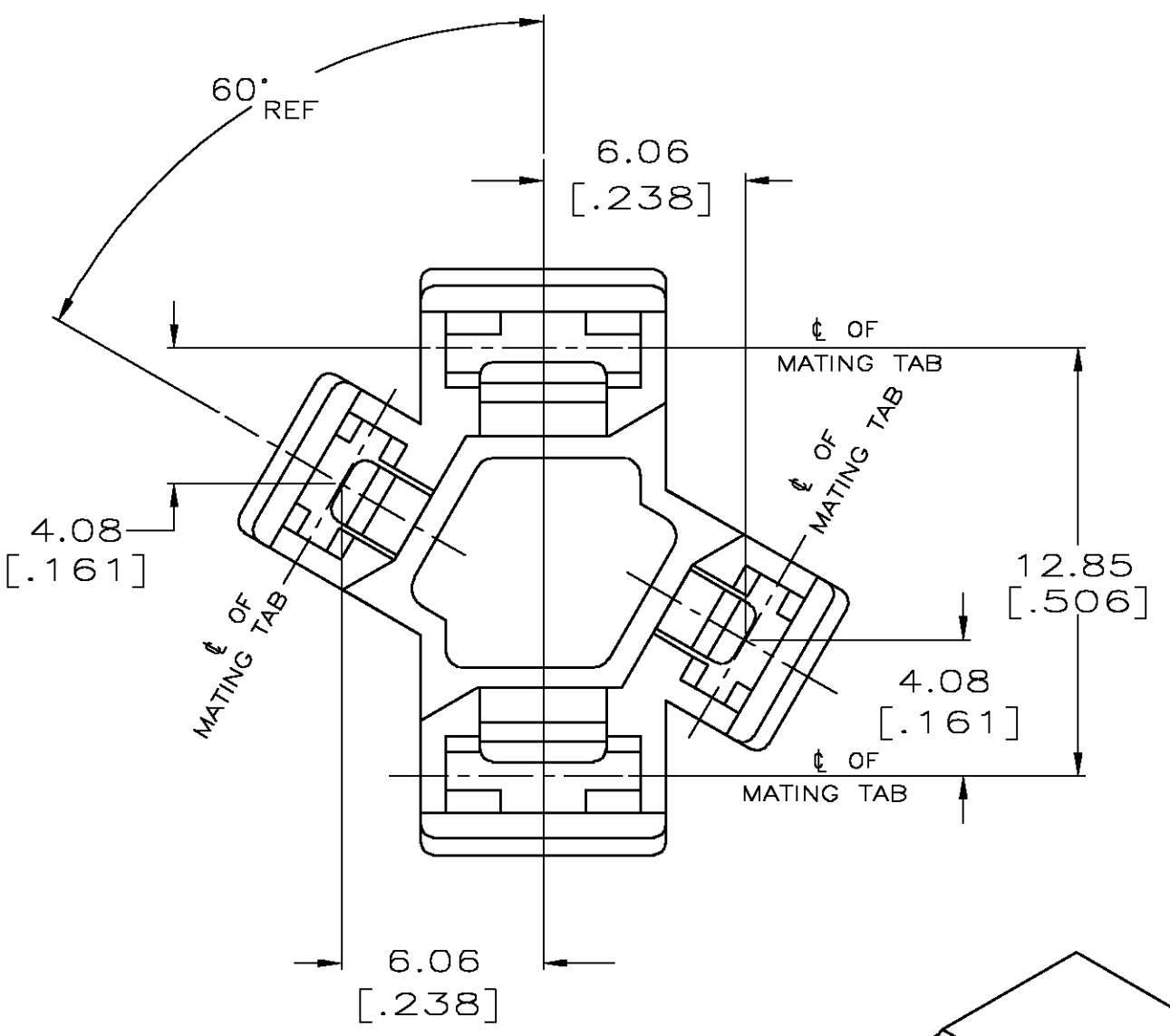

REF 3D VIEW

DO NOT SCALE PRINT. UNLESS SPECIFIED. DIMENSIONS IN mm [INCHES]. TOLERANCES ON : 2 PLC DEC ± - 3 PLC DEC ± 0.25 [.010] ANGLES ± -		DR 30NOV00 JR RUTH		521251-1 PART NO	
MATERIAL 4/6/ NYLON 150° C		CHK 30NOV00 MS FEHER		AMP AMP Incorporated Harrisburg, PA 17105-3608	
FINISH NATURAL		APPD 30NOV00 P DESANTIS		NAME HOUSING, RECEPTACLE, FASTON, 2.79 [.110] & 4.75 [.187] SERIES	
WEIGHT -		APPD 30NOV00 P DESANTIS		SIZE C 00779	
APPLICATION SPEC -		PRODUCT SPEC -		DRAWING NO 521251	
SCALE 5:1		SHEET 10F 1			

CUSTOMER DRAWING