

引き出し方向

PULL OUT  
DIRECTION

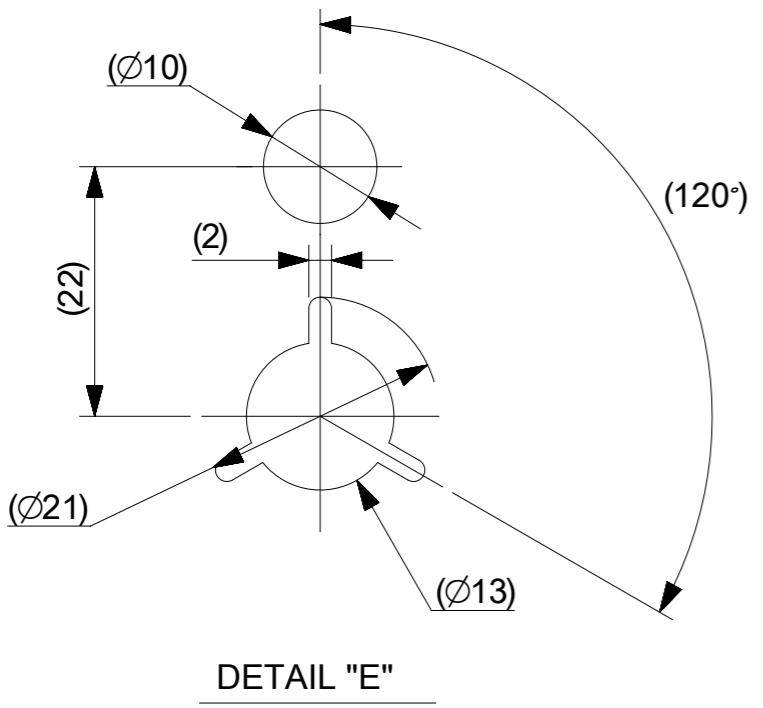
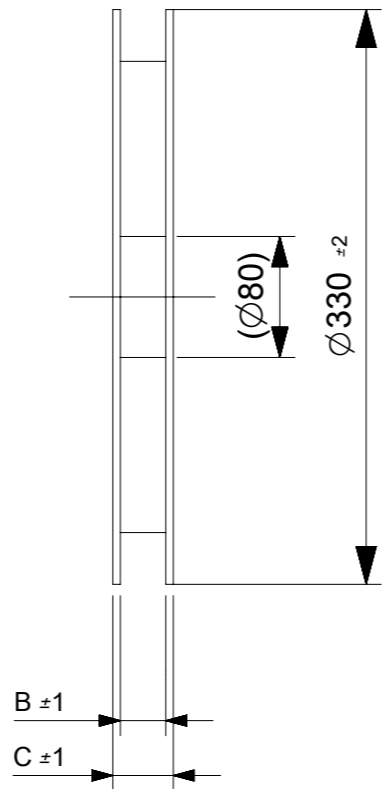
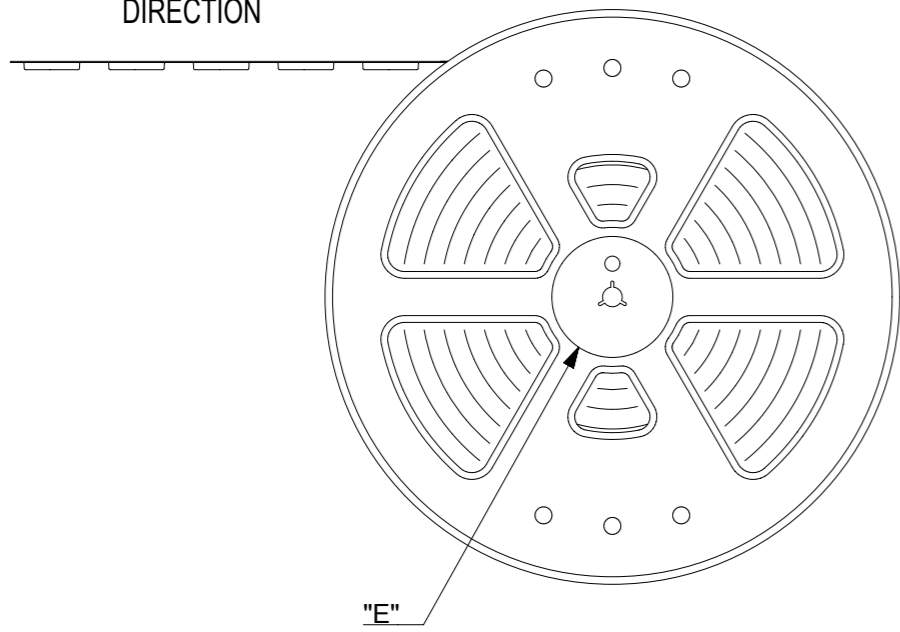

DETAIL "E"

NOTES

- 梱包数量 : 3000個 / リール  
NUMBER OF CONNECTORS : 3000PCS/REEL.
- リードテープ長さ  
LEAD TAPE LENGTH.
- トップテープの剥離強度については、IEC60286-3に準拠。  
TOP TAPE PEEL FORCE IS DEFINED BY IEC60286-3.
- 製品詳細寸法については製品単体図面を参照下さい。  
FOR DETAILED DIMENTIONS, SEE PRODUCT DRAWOING.
- 材料 MATERIAL  
キャリアテープ(CARRIER TAPE):ポリスチレン(POLYSTYRENE)  
トップテープ(TOP TAPE):PET, OTHER  
リール(REEL):ポリスチレン(PS)リサイクル材を含む  
POLYSTYRENE(PS) RECYCLE MATERIAL CONTAINED
- ELV及びRoHS適合品  
ELV AND RoHS COMPLIANT.

THIS DRAWING CONTAINS INFORMATION THAT IS PROPRIETARY TO MOLEX ELECTRONIC TECHNOLOGIES, LLC AND SHOULD NOT BE USED WITHOUT WRITTEN PERMISSION

EC NO: 106015 DRWN: YISHIDA CHK'D: KTANAKA03 APPR: KMORIKAWA	2016/02/24	GENERAL TOLERANCES (UNLESS SPECIFIED) ANGULAR TOL ± ° 4 PLACES ± 3 PLACES ± 2 PLACES ± 1 PLACE ± 0 PLACES ±	DIMENSION UNITS	SCALE				
	2016/06/28		MM	1:1				
	2016/06/28		DRWN BY	DATE		0.4BB H=0.8 ST8 PLUG ASSY. EMBSTP PKG		
			YISHIDA	2016/02/24				
			CHK'D BY	DATE	PRODUCT CUSTOMER DRAWING			
			KTANAKA03	2016/06/28				
			APPR BY	DATE	SERIES	MATERIAL NUMBER	CUSTOMER	
			KMORIKAWA	2016/06/28	504248	SEE SHEET 2,3 &4	GENERAL	
			DRAWING SIZE	THIRD ANGLE PROJECTION	DOCUMENT NUMBER	DOC TYPE	DOC PART	SHEET NUMBER
			A3		5042480000	PSD	000	1 OF 4

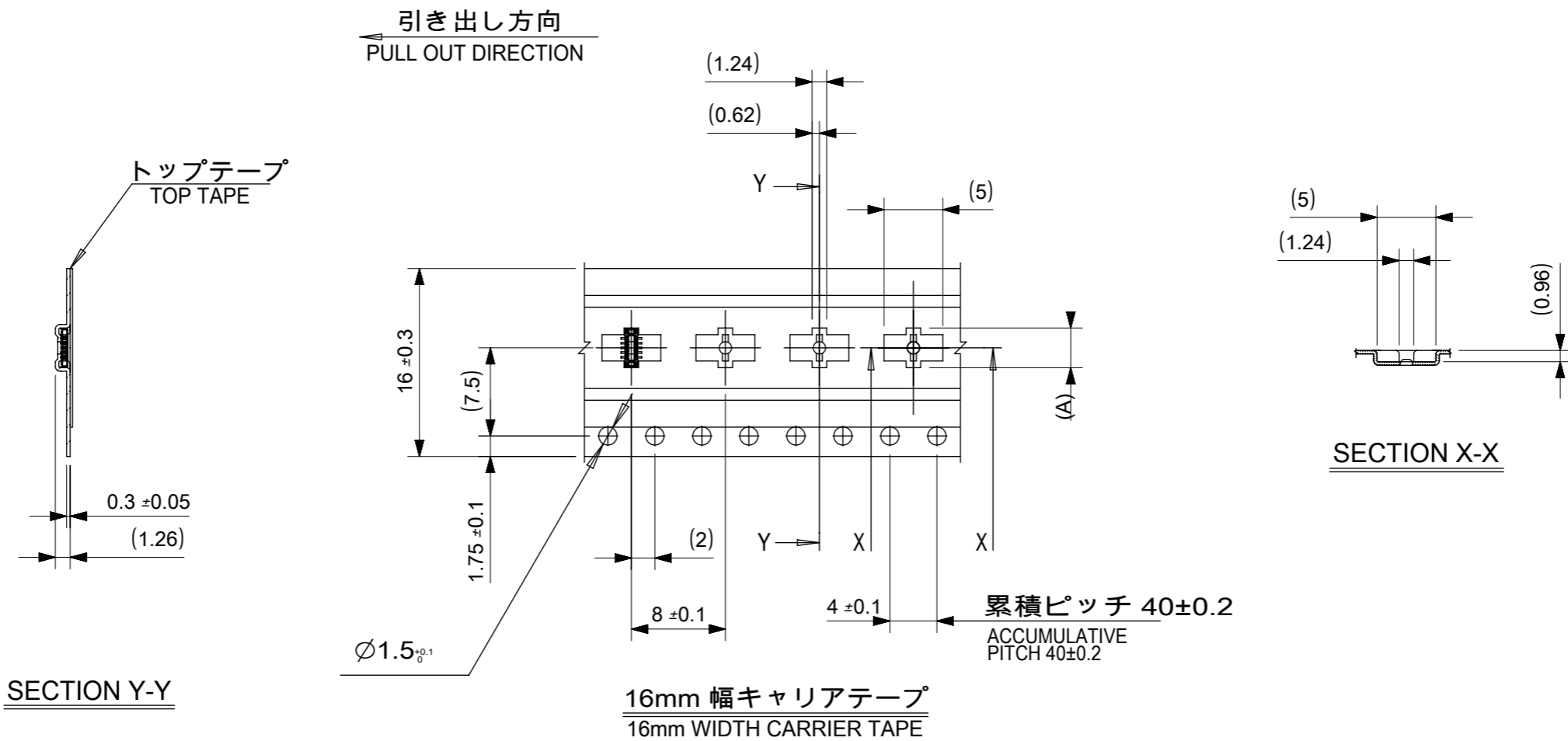

16	21.4	17.4	3.38	504248-1010	○	---	10
キャリアテープ幅 CARRIER TAPE WIDTH	C	B	(A)	MATERIAL No.	量産品 MASS PRODUCTION	試作対応 LOW VOL. TOOL	極数 CIRCUIT
					サンプル供給 SAMPLE PREPARATION		
MODEL No.						504248-**10	

THIS DRAWING CONTAINS INFORMATION THAT IS PROPRIETARY TO MOLEX ELECTRONIC TECHNOLOGIES, LLC AND SHOULD NOT BE USED WITHOUT WRITTEN PERMISSION

EC NO: 106015 DRWN: YISHIDA CHK'D: KTANAKA03 APPR: KMORIKAWA	2016/02/24	GENERAL TOLERANCES (UNLESS SPECIFIED)	DIMENSION UNITS	SCALE				
	2016/06/28	ANGULAR TOL ± °	MM	2:1				
	2016/06/28	4 PLACES ±	DRWN BY	DATE		0.4BB H=0.8 ST8 PLUG ASSY. EMBSTP PKG		
		3 PLACES ±	YISHIDA	2016/02/24				
		2 PLACES ±	CHK'D BY	DATE		PRODUCT CUSTOMER DRAWING		
	1 PLACE ±	KTANAKA03	2016/06/28					
	0 PLACES ±	APPR BY	DATE	SERIES	MATERIAL NUMBER	CUSTOMER		
				504248	SEE CHART	GENERAL		
		DRAFT WHERE APPLICABLE MUST REMAIN WITHIN DIMENSIONS	DRAWING SIZE	THIRD ANGLE PROJECTION	DOCUMENT NUMBER	DOC TYPE	DOC PART	SHEET NUMBER
			A3		5042480000	PSD	000	2 OF 4

引き出し方向  
PULL OUT DIRECTION

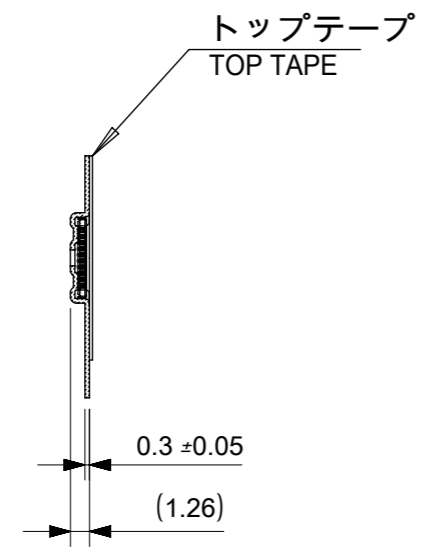

SECTION Y-Y

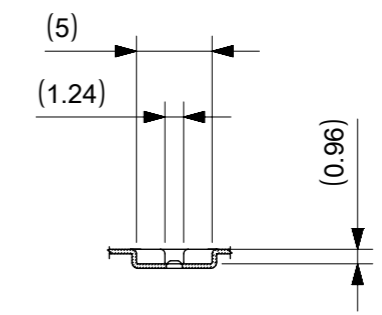
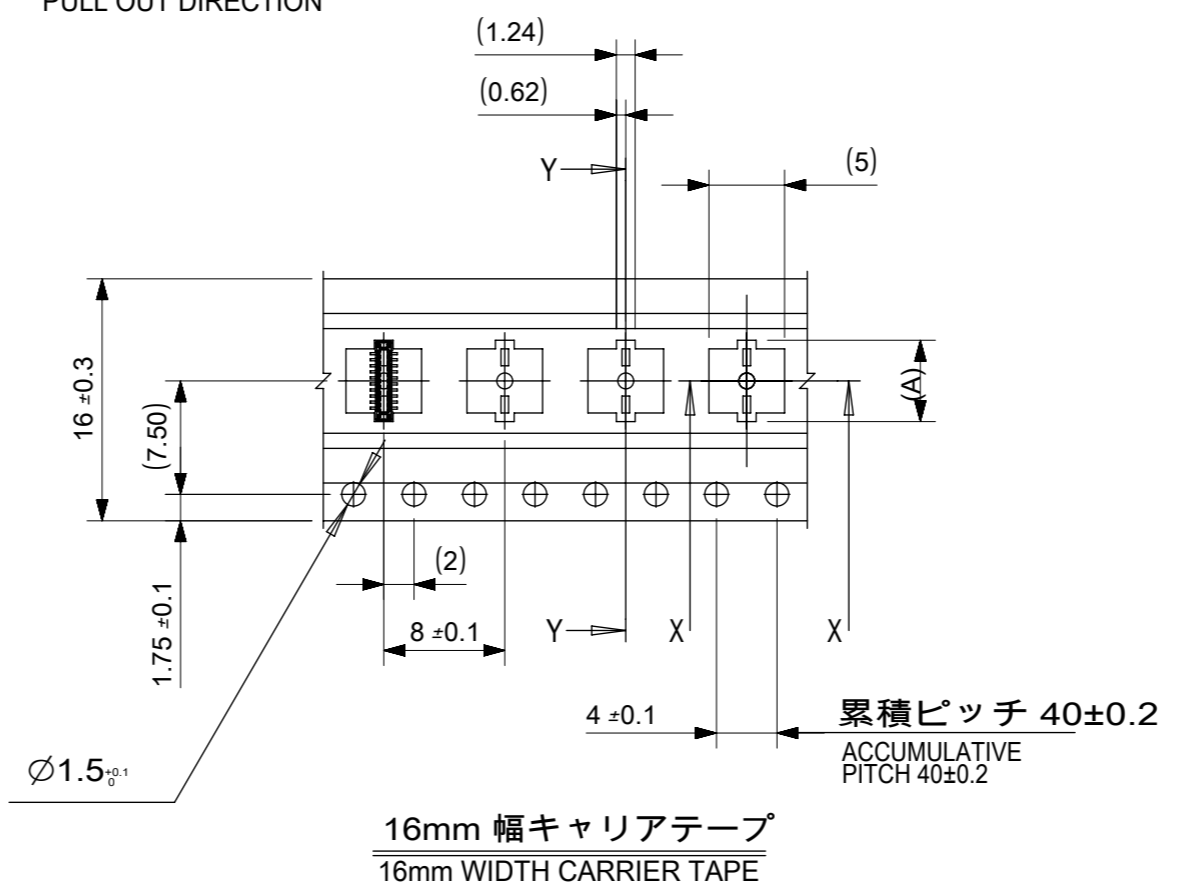

SECTION X-X

16	21.4	17.4	6.18	504248-2410	○	---	24
			5.38	504248-2010	○	---	20
			4.58	504248-1610	○	---	16
			3.78	504248-1210	○	---	12
キャリアテープ幅 CARRIER TAPE WIDTH	C	B	(A)	MATERIAL No.	量産品 MASS PRODUCTION	試作対応 LOW VOL. TOOL	極数 CIRCUIT
				サンプル供給 SAMPLE PREPARATION			
				MODEL No.		504248-**10	

THIS DRAWING CONTAINS INFORMATION THAT IS PROPRIETARY TO MOLEX ELECTRONIC TECHNOLOGIES, LLC AND SHOULD NOT BE USED WITHOUT WRITTEN PERMISSION

EC NO: 106015 DRWN: YISHIDA CHK'D: KTANAKA03 APPR: KMORIKAWA	2016/02/24	GENERAL TOLERANCES (UNLESS SPECIFIED)	DIMENSION UNITS	SCALE				
	2016/06/28	ANGULAR TOL ± °	MM	2:1				
	2016/06/28	4 PLACES ±	DRWN BY	DATE				
		3 PLACES ±	YISHIDA	2016/02/24				
		2 PLACES ±	CHK'D BY	DATE				
	1 PLACE ±	KTANAKA03	2016/06/28		0.4BB H=0.8 ST8 PLUG ASSY. EMBSTP PKG			
	0 PLACES ±	APPR BY	DATE					
		KMORIKAWA	2016/06/28					
DRAFT WHERE APPLICABLE MUST REMAIN WITHIN DIMENSIONS		DRAWING SIZE	THIRD ANGLE PROJECTION		PRODUCT CUSTOMER DRAWING			
A	REV	A3			SERIES	MATERIAL NUMBER	CUSTOMER	
					504248	SEE CHART	GENERAL	
					DOCUMENT NUMBER	DOC TYPE	DOC PART	SHEET NUMBER
					5042480000	PSD	000	3 OF 4

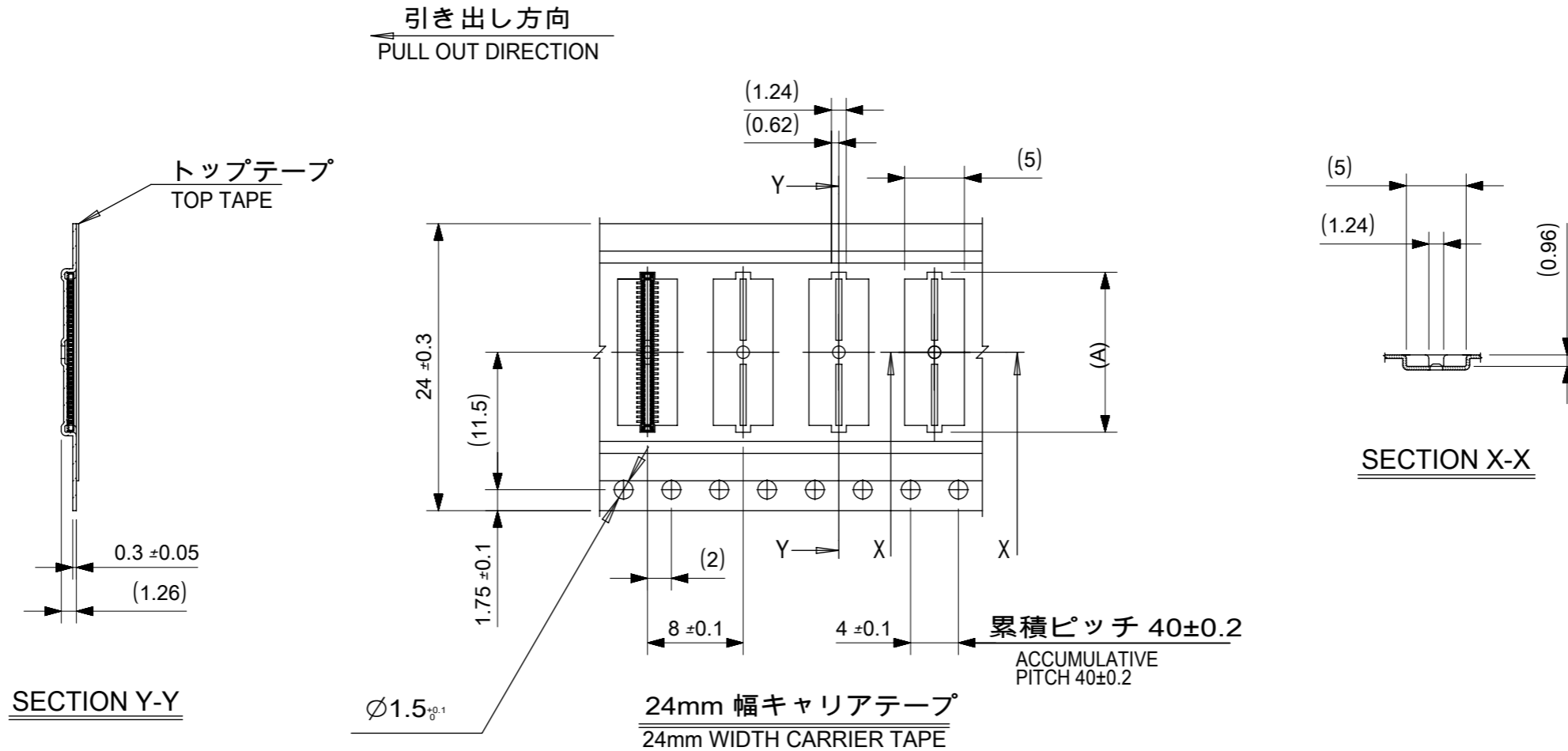

24	29.4	25.4	11.38	504248-5010	○	---	50
			9.38	504248-4010	○	---	40
			8.98	504248-3810	○	---	38
			8.18	504248-3410	○	---	34
			7.38	504248-3010	○	---	30
キャリアテープ幅 CARRIER TAPE WIDTH	C	B	(A)	MATERIAL No.	量産品 MASS PRODUCTION	試作対応 LOW VOL. TOOL	極数 CIRCUIT
				サンプル供給 SAMPLE PREPARATION			
				MODEL No.		504248-**10	

THIS DRAWING CONTAINS INFORMATION THAT IS PROPRIETARY TO MOLEX ELECTRONIC TECHNOLOGIES, LLC AND SHOULD NOT BE USED WITHOUT WRITTEN PERMISSION

EC NO: 106015 DRWN: YISHIDA CHK'D: KTANAKA03 APPR: KMORIKAWA	2016/02/24	GENERAL TOLERANCES (UNLESS SPECIFIED)	DIMENSION UNITS	SCALE				
	2016/06/28	ANGULAR TOL ± °	MM	2:1				
	2016/06/28	4 PLACES ±	DRWN BY	DATE		0.4BB H=0.8 ST8 PLUG ASSY. EMBSTP PKG		
		3 PLACES ±	YISHIDA	2016/02/24				
		2 PLACES ±	CHK'D BY	DATE		PRODUCT CUSTOMER DRAWING		
		1 PLACE ±	KTANAKA03	2016/06/28				
	0 PLACES ±	APPR BY	DATE	SERIES	MATERIAL NUMBER	CUSTOMER		
				504248	SEE CHART	GENERAL		
					DOCUMENT NUMBER	DOC TYPE	DOC PART	SHEET NUMBER
					5042480000	PSD	000	4 OF 4

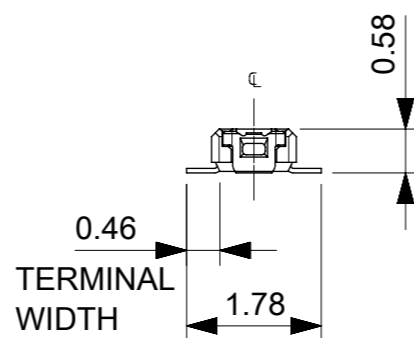
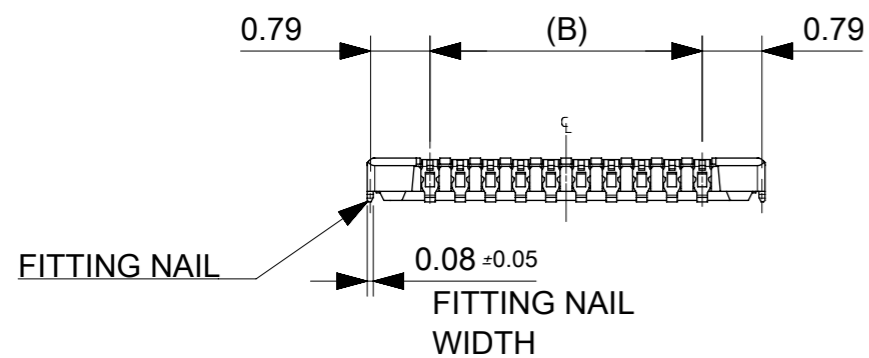
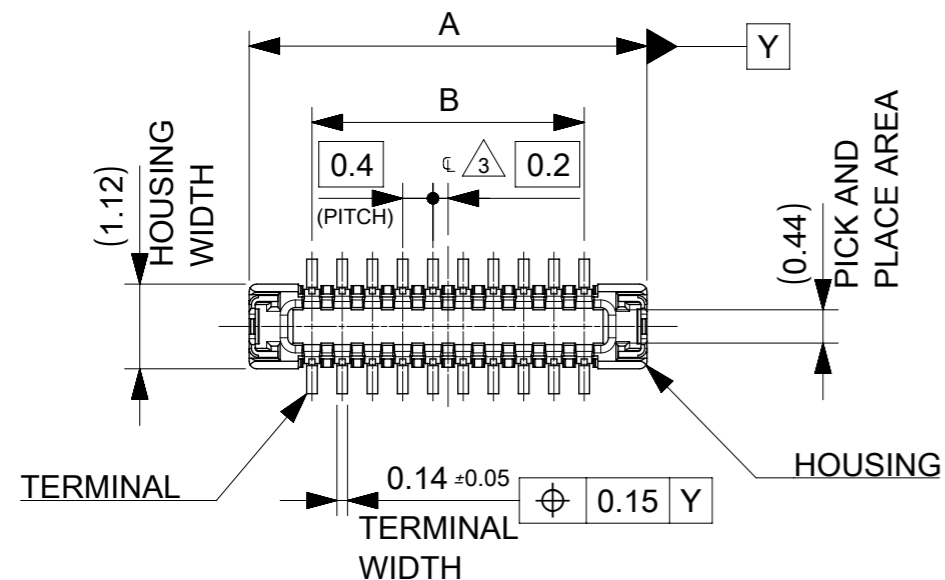

注記 NOTES

1.使用材料 MATERIAL

ハウジング : 液晶ポリマー ( LCP ) UL94V-0 ( 黒 )  
 HOUSING: LIQUID CRYSTAL POLYMER(LCP), UL94V-0, (COLOR: BLACK)  
 ターミナル : 銅合金  
 TERMINAL: COPPER ALLOY  
 補強金具 : 銅合金  
 FITTING NAIL: COPPER ALLOY

2.メッキ仕様 PLATING

ターミナル TERMINAL  
 金メッキ  
 GOLD  
 下地 : ニッケルメッキ  
 UNDER PLATING: NICKEL  
 ※コンタクト部とテール部はニッケルメッキによって分断されている金メッキです。  
 DIVIDE INTO PARTS THE GOLD PLATING OF THE CONTACT  
 AND THE TAIL PART BY THE NICKEL PLATING.

補強金具 FITTING NAIL  
 金メッキ ( テール部のみ )  
 GOLD (ONLY TAIL PART)  
 下地 : ニッケルメッキ  
 UNDER PLATING : NICKEL OVERALL

△<sub>3</sub> ( 全極数/2 ) = 偶数の場合に適用。  
 APPL FOR (CIRCUIT/2)= EVEN.

4.嵌合相手 : 504208 シリーズ  
 MATE WITH : 504208 SERIES.

5.テール平坦度は0.08以下  
 テール及び金具の平坦度は、0.1以下。  
 TAIL COPLANARITY TO BE 0.08 MAX.  
 TAIL AND FITTING NAIL COPLANARITY TO BE 0.1 MAX.

6.ELV 及び RoHS適合品  
 ELV AND RoHS COMPLIANT.

7.6	9.26	504248-4010	○	---	40
7.2	8.86	504248-3810	○	---	38
6.4	8.06	504248-3410	○	---	34
B	A	EMBOSSED TAPE PACKAGE	MASS PRODUCTION	LOW VOL. TOOL	CIRCUIT
		ORDER NO.	SAMPLE PREPARATION		
CONNECTOR SERIES NO. : 504248-**09					

THIS DRAWING CONTAINS INFORMATION THAT IS PROPRIETARY TO MOLEX ELECTRONIC TECHNOLOGIES, LLC AND SHOULD NOT BE USED WITHOUT WRITTEN PERMISSION

EC NO: 106015 DRWN: YSHIDA CHK'D: KTANAKA03 APPR: KMORIKAWA	2016/02/24	GENERAL TOLERANCES (UNLESS SPECIFIED)	DIMENSION UNITS	SCALE	<b>molex</b> <sup>®</sup>	
	2016/06/28		MM	10:1		
	2016/06/28		ANGULAR TOL ± 1.0 °	DRWN BY		DATE
			4 PLACES ± 0.03	YSHIDA		2016/02/24
	3 PLACES ± 0.05	CHK'D BY	DATE			
	2 PLACES ± 0.1	KTANAKA03	2016/06/28			
	1 PLACE ± 0.2	APPR BY	DATE			
	0 PLACES ± 0.25	KMORIKAWA	2016/06/28			
	DRAFT WHERE APPLICABLE MUST REMAIN WITHIN DIMENSIONS	DRAWING SIZE	THIRD ANGLE PROJECTION			
A	REV	A3				

0.4 BB CONN. H=0.8 ST8 PLUG ASSY.

PRODUCT CUSTOMER DRAWING

SERIES	MATERIAL NUMBER	CUSTOMER
504248	SEE CHART	GENERAL
DOCUMENT NUMBER	DOC TYPE	DOC PART
5042481000	PSD	000
SHEET NUMBER		
1 OF 2		

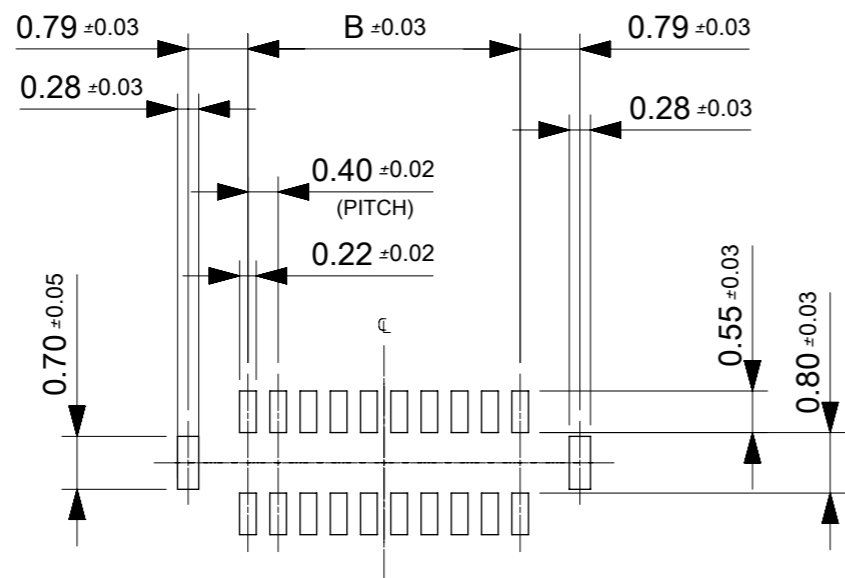

P.W.BOARD PATTERN LAYOUT (REFERENCE)

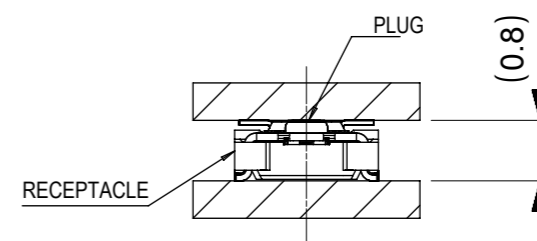

MATED DRAWING (REFERENCE)

THIS DRAWING CONTAINS INFORMATION THAT IS PROPRIETARY TO MOLEX ELECTRONIC TECHNOLOGIES, LLC AND SHOULD NOT BE USED WITHOUT WRITTEN PERMISSION

EC NO: 106015 DRWN: YISHIDA CHK'D: KTANAKA03 APPR: KMORIKAWA	2016/02/24	GENERAL TOLERANCES (UNLESS SPECIFIED)		DIMENSION UNITS	SCALE					
	2016/06/28	ANGULAR TOL ± 1.0 °		MM	10:1					
	2016/06/28	4 PLACES ± 0.03	DRWN BY	DATE			0.4 BB CONN. H=0.8 ST8 PLUG ASSY.			
		3 PLACES ± 0.05	YISHIDA	2016/02/24						
		2 PLACES ± 0.1	CHK'D BY	DATE			PRODUCT CUSTOMER DRAWING			
	1 PLACE ± 0.2	KTANAKA03	2016/06/28							
	0 PLACES ± 0.25	APPR BY	DATE		SERIES	MATERIAL NUMBER	CUSTOMER			
			DRAFT WHERE APPLICABLE MUST REMAIN WITHIN DIMENSIONS		DRAWING SIZE	THIRD ANGLE PROJECTION	504248	SEE SHEET 1	GENERAL	
				A3			DOCUMENT NUMBER	DOC TYPE	DOC PART	SHEET NUMBER
							5042481000	PSD	000	2 OF 2