

PRODUCT NUMBER
48070-000
48070-000LF

NOTE 8

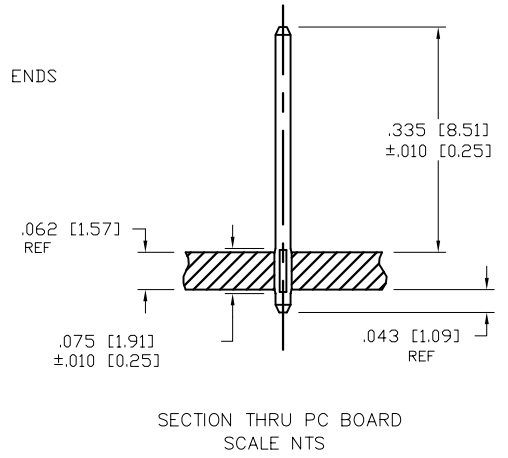

- NOTES:
- MATERIAL:
POST 3/4 HARD PHOSPHOR BRONZE,
ASTM B-159-66. PLATED WITH 30u" [0.76u]
MIN. GOLD OVER 50u" [1.27u] MIN NICKEL.
 - BURNISH MARKS ON PIN PERMITTED.
BURR .003 [0.08] MAX., BULGE .0005 [0.013] MAX. TYP.
 - SEE PRODUCT SPECIFICATION BUS-12-064
FOR P.C. BOARD HOLE DIAMETER AND P.C. BOARD
HOLE PLATING INFORMATION.
 - PIN TO FERRULE RETENTION 2 LB [0.90 KG.] MIN.
 - .039 [0.99] +.001 [0.03] -.002 [0.05] FEATURE
SHALL BE CONCENTRIC TO WIRE DIA WITHIN
.004 [0.10] TIR.
 - R.003 [0.08] MAX TYP (4) PLACES ON WIRE
WRAP PORTION OF PIN.
 - CARRIER STRIP FOR CONVEYING PURPOSES ONLY.
 - PART NUMBERS WITH AN LF SUFFIX MEET EUROPEAN
UNION DIRECTIVES AND OTHER COUNTRY
REGULATIONS AS DESCRIBED IN GS-22-008.

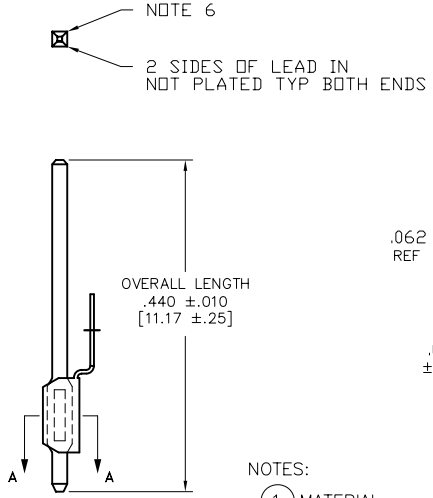
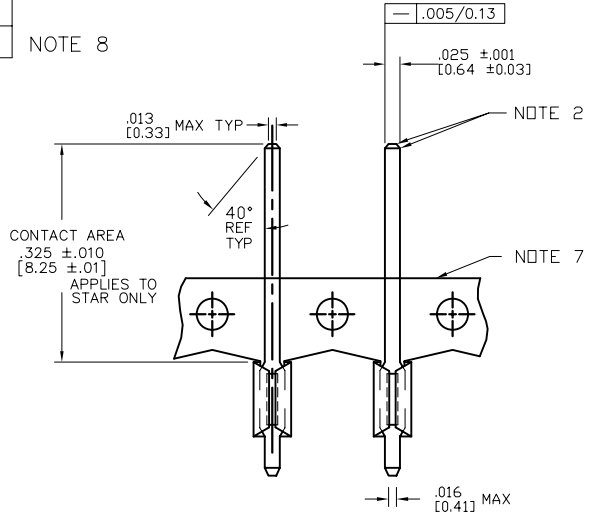
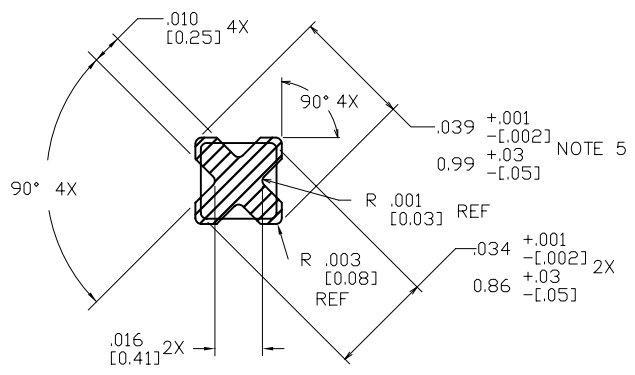

SECTION A-A
SCALE NTS
ALL DIM TYP
WITHOUT FERRULE

mat'l. code		surface		tolerance		projection		product family	
SEE NOTE 1		ASME Y14.5		ASME Y14.5		INCH/MM		PIN PRODUCTS	
ltr	ecp no	dr	date	tolerances unless	otherwise specified	INCH/MM		title	
H	V08-0353	HTB	2008-08-14	angles	XX*01/X*3	INCH/MM		BERGPIN® .200" [5.08] cc	
-	-	-	-		XXX*005/XX*13	scale N.T.S		.039" [0.99] DIA. STAR	
C	V60730	EPK	1996-06-25	0° ±2'	XXXX*0020/XXX*051	scale N.T.S		dwg no	
D	V01594	JRW	2000-07-11	dr	E. KROPIEWINCKI	1996-06-25		sheet 1 of 1	
E	V10857	JRW	2001-02-13	engr	L. FYE	1996-06-25		size	
F	V05-0316	VS	2005-04-16	chr	T. BREWBAKER	1996-06-25		48070	
G	V06-0682	JRV	2006-07-18	appd	L. FYE	1996-06-25		A4	
sheet	revision	H						type	
index	sheet	1						CUSTOMER Drawing	