

PART NUMBER	CRIMP SIZE	NUMBER OF TERMINALS PER REEL	PLATING	DIM 'A' WIDTH	DIM 'B' HEIGHT
46819-0011	10	900	100μ INCHES OF MATTE SELECT TIN OVER 50μ INCHES OF NICKEL OVERALL WITH 30μ INCHES OF SELECT GOLD	5.37±0.25 .210±.010	5.97±0.38 .235±.015
46819-0012	8	900		7.12±0.25 .280±.010	7.84±0.30 .309±.012
46819-0013	6	900		7.62±0.25 .300±.010	8.92±0.30 .350±.012

NOTES:

- MATERIAL: COPPER ALLOY .80/.032 THICK
- FINISH: PER MOLEX PLATING SPECIFICATION ES-88 - SEE CHART
- FOR CRIMP TOOLING CONTACT MOLEX OR VISIT THE MOLEX WEBSITE AT: WWW.MOLEX.COM
- SEE PRODUCT SPECIFICATION: PS-46819-001 FOR MORE INFORMATION
- FOR CRIMP SET UP INFORMATION SEE MOLEX APPLICATION SPECIFICATION DOCUMENT:
6 AWG - ATS-638320600
8 AWG - ATS-638320700
10 AWG - ATS-638320800
- DESIGNED TO MATE WITH MOLEX P/N 46817-****
- TERMINAL FOR USE WITH HOUSINGS 46818-000* & 170351-000*
- TERMINAL FOR USE WITH TPA 46821-0001

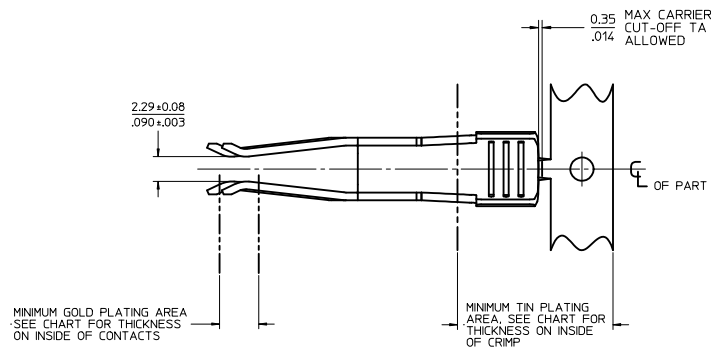
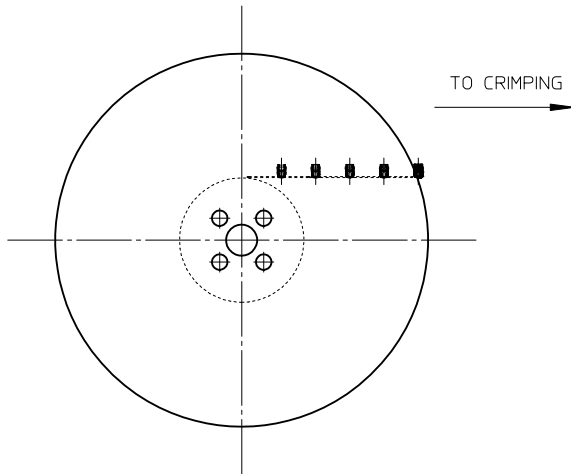
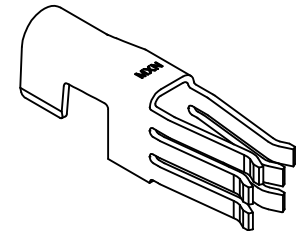
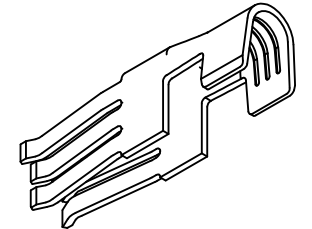
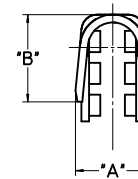
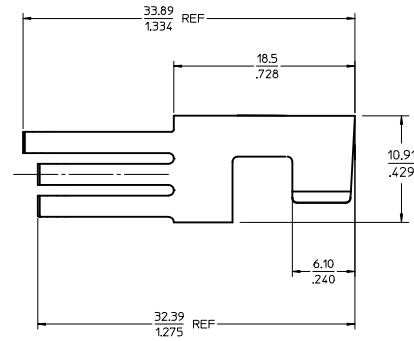
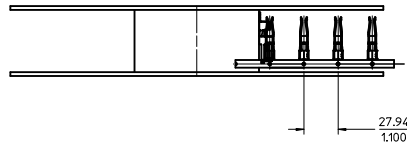

REV NOTE & CHART EC NO: UCP2012-3021 DRAWN: OUILES 2012/05/08 CHKD: HKRADI/MAS 2012/05/08 APPR: APATEL 2012/05/15	QUALITY SYMBOLS	GENERAL TOLERANCES (UNLESS SPECIFIED)	DIMENSION STYLE	SCALE	DESIGN UNITS	THIRD ANGLE PROJECTION
	▽=0 ▽=0 ▽=0	mm INCH 4 PLACES ±.05 ±.005 3 PLACES ±.013 ±.010 2 PLACES ±.025 ±.015 1 PLACE ±.030 ±.020 0 PLACE ±.040 ±.030	MM/IN	4:1	METRIC	☉
	ANGULAR ±1/2° DRAFT WHERE APPLICABLE MUST REMAIN WITHIN DIMENSIONS		DRAWN BY DATE JOUILES 2009/03/09			TITLE GUARDIAN TERMINAL - HIGH POWER CRIMP CONTACT
			CHECKED BY DATE MDATA 2009/03/09			molex
			APPROVED BY DATE APATEL 2009-03/10			MATERIAL NO. DOCUMENT NO. SEE CHART SD-46819-001
						SHEET NO. 1 OF 1

PART NUMBER	CRIMP SIZE	NUMBER OF TERMINALS PER REEL	PLATING	DIM 'A' WIDTH	DIM 'B' HEIGHT
46819-0011	10	900	100μ INCHES OF MATTE SELECT TIN OVER 50μ INCHES OF NICKEL OVERALL WITH 30μ INCHES OF SELECT GOLD	5.37±0.25 .210±.010	5.97±0.38 .235±.015
46819-0012	8	900		7.12±0.25 .280±.010	7.84±0.30 .309±.012
46819-0013	6	900		7.62±0.25 .300±.010	8.92±0.30 .350±.012

NOTES:

- MATERIAL: COPPER ALLOY .80/.032 THICK
- FINISH: PER MOLEX PLATING SPECIFICATION ES-88 - SEE CHART
- FOR CRIMP TOOLING CONTACT MOLEX OR VISIT THE MOLEX WEBSITE AT: WWW.MOLEX.COM
- SEE PRODUCT SPECIFICATION: PS-46819-001 FOR MORE INFORMATION
- FOR CRIMP SET UP INFORMATION SEE MOLEX APPLICATION SPECIFICATION DOCUMENT:
6 AWG - ATS-638320600
8 AWG - ATS-638320700
10 AWG - ATS-638320800
- DESIGNED TO MATE WITH MOLEX P/N 46817-****
- TERMINAL FOR USE WITH HOUSINGS 46818-000* & 170351-000*
- TERMINAL FOR USE WITH TPA 46821-0001

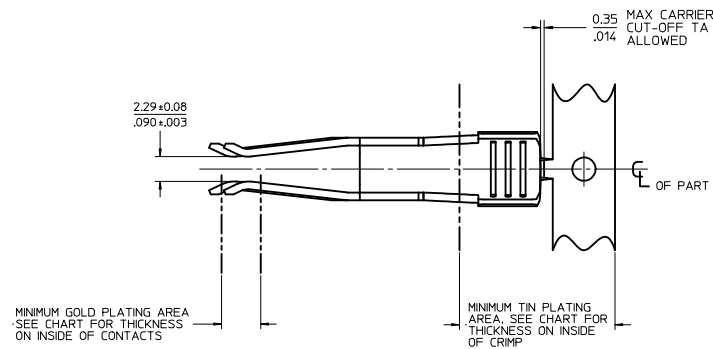
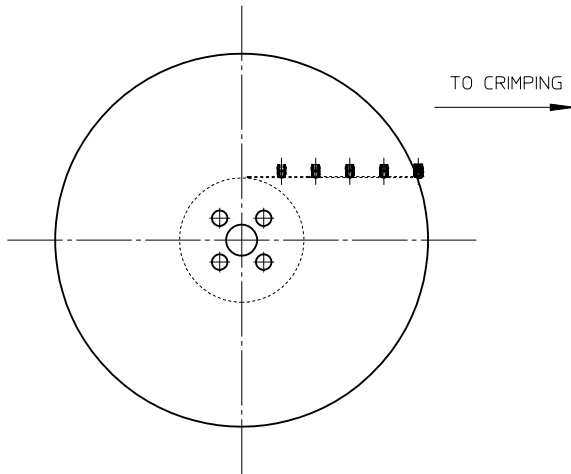
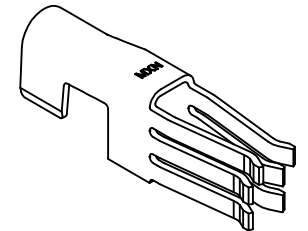
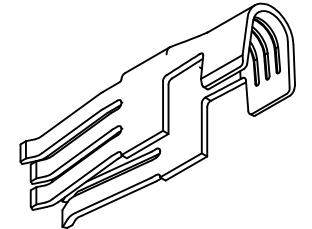
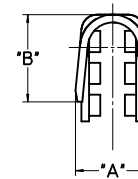
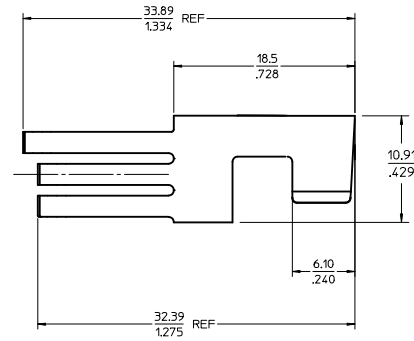
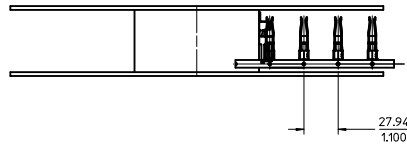

REV NOTE & CHART EC NO: UCP2012-3021 DRAWN: DOUTLES 2012/05/08 CHKD: HKRADI/MAS 2012/05/08 APPR: APATEL 2012/05/15	QUALITY SYMBOLS	GENERAL TOLERANCES (UNLESS SPECIFIED)	DIMENSION STYLE	SCALE	DESIGN UNITS	THIRD ANGLE PROJECTION
	▽=0 ▽=0 ▽=0	mm INCH 4 PLACES ±.05 ±.005 3 PLACES ±.013 ±.010 2 PLACES ±.025 ±.015 1 PLACE ±.030 ±.020 0 PLACE ±.040 ±.030	MM/IN	4:1	METRIC	☉
	ANGULAR ±1/2° DRAFT WHERE APPLICABLE MUST REMAIN WITHIN DIMENSIONS		DRAWN BY DATE JOUILES 2009/03/09			TITLE GUARDIAN TERMINAL - HIGH POWER CRIMP CONTACT
			CHECKED BY DATE MDATA 2009/03/09			molex
			APPROVED BY DATE APATEL 2009-03/10			MATERIAL NO. DOCUMENT NO. SEE CHART SD-46819-001
						SHEET NO. 1 OF 1
			THIS DRAWING CONTAINS INFORMATION THAT IS PROPRIETARY TO MOLEX INCORPORATED AND SHOULD NOT BE USED WITHOUT WRITTEN PERMISSION			