

NOTES:

1. MATERIAL: SEE TABLE.
2. FINISHES: SEE TABLE.
3. PRODUCT SPECIFICATION: NOT REQUIRED.
4. "XX" REFERS TO NUMBER OF CIRCUITS.
5. ROHS COMPLIANT.

3	5	SCREW #8-32X.290 BHD PHSL (OPT -A)	BRASS	NICKEL PLATE
2	5	TERMINAL 17 PC 8-32	BRASS	TIN PLATE
1	1	INSULATOR, SR, NO MTG.	POLYESTER (PBT)	BLACK
ITEM	QTY	DESCRIPTION	MATERIAL	FINISH

INITIAL RELEASE
 EC NO: WNA2009-0404
 DRAWN: ENC INAS 2009/01/15
 CHKD: CYORK 2009/01/15
 APPR: JMACNE IL 2009/01/16

QUALITY SYMBOLS
 ▽=0
 ▽=0

GENERAL TOLERANCES (UNLESS SPECIFIED)	
	mm INCH
4 PLACES	± --- ± ---
3 PLACES	± --- ± .005
2 PLACES	± 0.13 ± .01
1 PLACE	± 0.3 ± ---
ANGULAR ± 2 °	
DRAFT WHERE APPLICABLE MUST REMAIN WITHIN DIMENSIONS	

DIMENSION STYLE
MM/IN

DRAWN BY JSCHOOLEY DATE 2006/05/18
 CHECKED BY EHILE DATE 2006/05/18
 APPROVED BY R. DEROSS DATE 2006/05/18

MATERIAL NO. SEE CHART

SIZE B

SCALE 2:1 DESIGN UNITS INCH

THIRD ANGLE PROJECTION

TITLE
 11.11 [.438] SR BTS ASY,
 PC TERMINAL, NO MTG,
 OVERSIZED SCREW, -A-C-17

MOLEX INCORPORATED

DOCUMENT NO. SD-38739-021 SHEET NO. 1 OF 2

THIS DRAWING CONTAINS INFORMATION THAT IS PROPRIETARY TO MOLEX INCORPORATED AND SHOULD NOT BE USED WITHOUT WRITTEN PERMISSION

# OF CIRCUITS "XX"	DIM. "A"		DIM. "B"		ASSEMBLY MATERIAL NO. (-A-C-17 OPT)
	mm	in	mm	in	
02	24.5	0.97	11.11	0.438	
03	35.7	1.40	22.23	0.875	
04	46.8	1.84	33.34	1.313	387390155
05	57.9	2.28	44.45	1.750	
06	69.0	2.72	55.56	2.188	
07	80.1	3.15	66.68	2.625	
08	91.2	3.59	77.79	3.063	387390002
09	102.3	4.03	88.90	3.500	
10	113.4	4.47	100.01	3.938	387390001
11	124.6	4.90	111.13	4.375	
12	135.7	5.34	122.24	4.813	
13	146.8	5.78	133.35	5.250	
14	157.9	6.22	144.46	5.688	
15	169.0	6.65	155.58	6.125	
16	180.1	7.09	166.69	6.563	
17	191.2	7.53	177.80	7.000	
18	202.3	7.97	188.91	7.438	
19	213.5	8.40	200.03	7.875	
20	224.6	8.84	211.14	8.313	
21	235.7	9.28	222.25	8.750	
22	246.8	9.72	233.36	9.188	
23	257.9	10.15	244.48	9.625	
24	269.0	10.59	255.59	10.063	
25	280.1	11.03	266.70	10.500	
26	291.2	11.47	277.81	10.938	
27	302.4	11.90	288.93	11.375	
28	313.5	12.34	300.04	11.813	
29	324.6	12.78	311.15	12.250	
30	335.7	13.22	322.26	12.688	

SEE SHEET ONE EC NO: WNAZ009-0404 DRWN: JENC INAS 2009/01/15 CHKD: CYORK 2009/01/15 APPR: JMACNE IL 2009/01/16	QUALITY SYMBOLS =0 =0	GENERAL TOLERANCES (UNLESS SPECIFIED)		DIMENSION STYLE		SCALE	DESIGN UNITS	THIRD ANGLE PROJECTION
				MM/IN		2:1	INCH	
				DRAWN BY DATE		TITLE		
				CHECKED BY DATE		11.11 [.438] SR BTS ASY, PC TERMINAL, NO MTG, OVERSIZED SCREW, -A-C-17		
		APPROVED BY DATE		MATERIAL NO.		MOLEX INCORPORATED		SHEET NO. 2 OF 2
		R. DEROSS 2006/05/18		SEE CHART		DOCUMENT NO. SD-38739-021		
		ANGULAR ± 2 °		DRAFT WHERE APPLICABLE MUST REMAIN WITHIN DIMENSIONS		THIS DRAWING CONTAINS INFORMATION THAT IS PROPRIETARY TO MOLEX INCORPORATED AND SHOULD NOT BE USED WITHOUT WRITTEN PERMISSION		

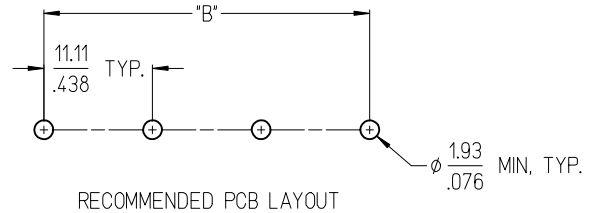
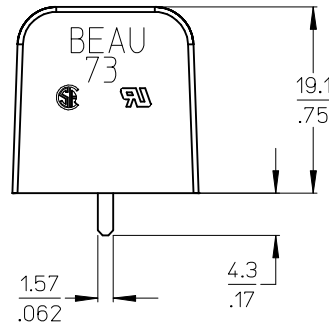
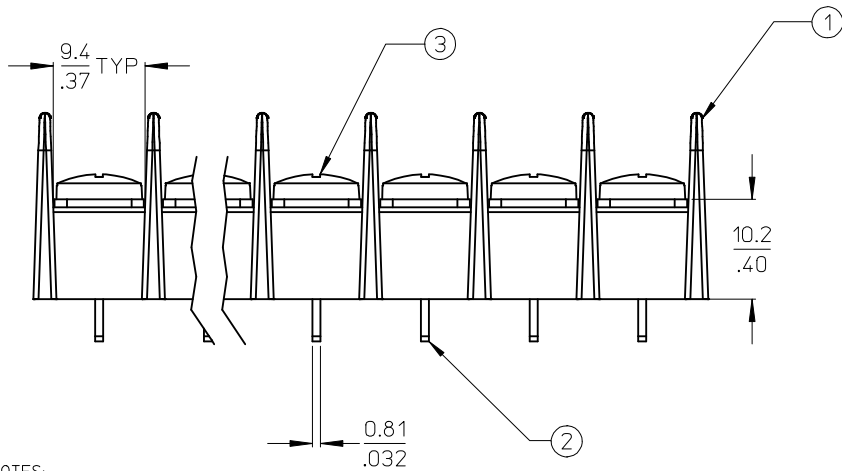
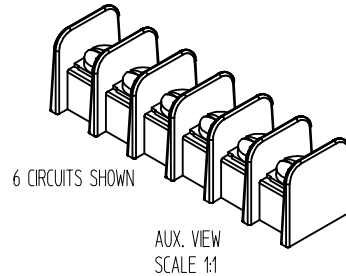
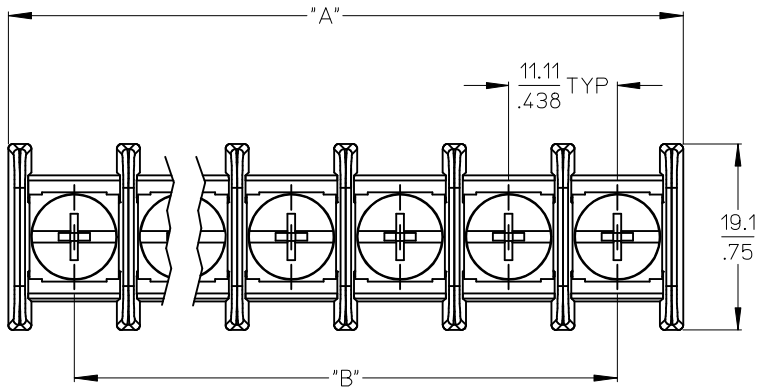

QTY CKTS	DIM "A"		DIM "B"		MATERIAL NO. -A-C-17 OPT
	MM	INCH	MM	INCH	
2	24.5	0.97	11.11	0.438	
3	35.7	1.40	22.23	0.875	
4	46.8	1.84	33.34	1.313	387390155
5	57.9	2.28	44.45	1.750	
6	69.0	2.72	55.56	2.188	
7	80.1	3.15	66.68	2.625	
8	91.2	3.59	77.79	3.063	387390002
9	102.3	4.03	88.90	3.500	
10	113.4	4.47	100.01	3.938	387390001
11	124.6	4.90	111.13	4.375	
12	135.7	5.34	122.24	4.813	
13	146.8	5.78	133.35	5.250	
14	157.9	6.22	144.46	5.688	
15	169.0	6.65	155.58	6.125	
16	180.1	7.09	166.69	6.563	
17	191.2	7.53	177.80	7.000	
18	202.3	7.97	188.91	7.438	
19	213.5	8.40	200.03	7.875	
20	224.6	8.84	211.14	8.313	
21	235.7	9.28	222.25	8.750	
22	246.8	9.72	233.36	9.188	
23	257.9	10.15	244.48	9.625	
24	269.0	10.59	255.59	10.063	
25	280.1	11.03	266.70	10.500	
26	291.2	11.47	277.81	10.938	
27	302.4	11.90	288.93	11.375	
28	313.5	12.34	300.04	11.813	
29	324.6	12.78	311.15	12.250	
30	335.7	13.22	322.26	12.688	

NOTES:

1. MATERIAL: SEE DETAILS
2. FINISHES: SEE DETAILS
3. PRODUCT SPECIFICATION: NOT REQUIRED
4. "XX" REFERS TO THE NUMBER OF CIRCUITS
5. ROHS COMPLIANT

ITEM	QTY.	DESCRIPTION	MATERIAL	FINISH
3	XX	#8-32 SCREW (OPT -A)	BRASS	NICKEL PLATE
2	XX	TERMINAL, 17 PC 8-32	BRASS	TIN PLATE
1	1	INSULATOR, SR, NO MTG	POLYESTER (PBT)	BLACK

INITIAL RELEASE EC NO: WINA2009-0537 DRWN: ENC INAS 2009/04/22 CHKD: CYORK 2009/05/11 APPR: JMACNE IL 2009/05/12 REV A	QUALITY SYMBOLS ▽=0 ▽=0	GENERAL TOLERANCES (UNLESS SPECIFIED) mm INCH 4 PLACES ± --- ± --- 3 PLACES ± --- ± .005 2 PLACES ± 0.13 ± .01 1 PLACE ± 0.3 ± --- ANGULAR ± 2°	DIMENSION STYLE MM/IN DRAWN BY JSCHOOLEY DATE 2006/05/18 CHECKED BY EHILE DATE 2006/05/18 APPROVED BY R. DEROSS DATE 2006/05/18	SCALE 2:1 DESIGN UNITS INCH THIRD ANGLE PROJECTION
	DRAFT WHERE APPLICABLE MUST REMAIN WITHIN DIMENSIONS		MATERIAL NO. SEE CHART SIZE B THIS DRAWING CONTAINS INFORMATION THAT IS PROPRIETARY TO MOLEX INCORPORATED AND SHOULD NOT BE USED WITHOUT WRITTEN PERMISSION	TITLE 11.11 [.438] SR BTS ASY, PC TERMINAL, NO MTG, OVERIZED SCREW, -A-C-17 MOLEX INCORPORATED DOCUMENT NO. SD-38739-023 SHEET NO. 1 OF 1