

4-521097-2 ✓ ACTIVE

Ultra-Fast | Ultra-Fast 250

TE Internal #: 4-521097-2

Quick Disconnects, Tab, 12 – 10 AWG Wire Size, 3.31 – 5.26 mm²

Wire Size, 6529 – 10382 CMA Wire Size, Ultra-Fast 250

[View on TE.com >](#)



Terminals & Splices > Quick Disconnects

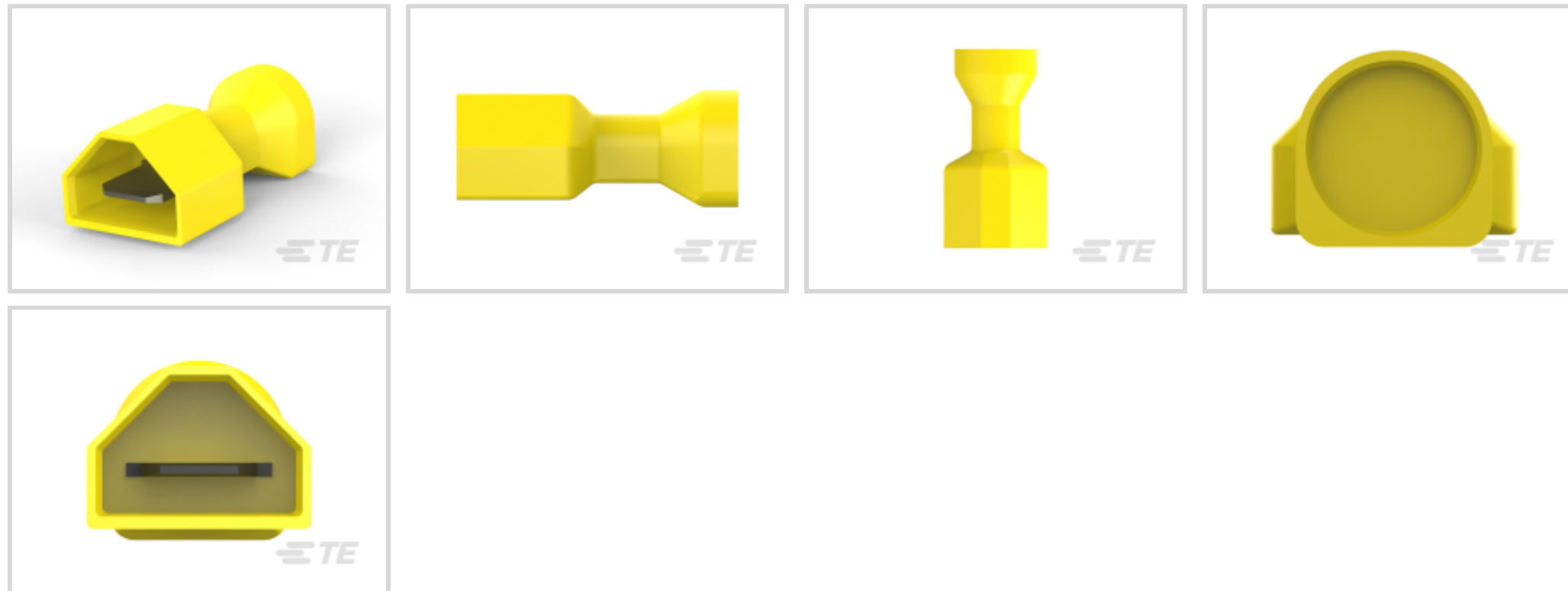

Quick Disconnect Terminal Type: **Tab**

Wire Size: **6529 – 10382 CMA**

Mating Tab Width: **6.35 mm [.25 in]**

Features

Product Type Features

Terminates To	Wire & Cable
Wire/Cable Type	Regular Wire
Wire Stop	No
Insertion Force	Normal
Sealable	No

Configuration Features

Connection Capacity	Single
---------------------	--------

Electrical Characteristics

Voltage (Max)	600 V
---------------	-------

Body Features

Insulation Material	Nylon
---------------------	-------

Contact Features

Quick Disconnect Terminal Type	Tab
Mating Tab Width	6.35 mm [.25 in]
Mating Tab Thickness	.81 mm [.032 in]
Terminal Orientation	Straight



Contact Base Material	Brass
Terminal Plating Material	Tin
Crimp Type	F-Crimp
Barrel Type	Closed

Mechanical Attachment

Mating Retention Type	Dimple
Wire Insulation Support	With

Dimensions

Accepts Wire Insulation Diameter Range	8.13 mm[.32 in]
Receptacle Terminal Stock Thickness	.41 mm[.016 in]
Overall Length	23.75 mm[.935 in]
Wire Size	6529 – 10382 CMA

Usage Conditions

Insulation Option	Uninsulated
Operating Temperature Range	-40 – 110 °C[-40 – 230 °F]

Industry Standards

UL Flammability Rating	UL 94V-2
UL Rating	Listed

Packaging Features

Packaging Quantity	1000
Packaging Method	Strip/Reel

Other

Barrel Color	Yellow
--------------	--------

Product Compliance

[For compliance documentation, visit the product page on TE.com>](#)

EU RoHS Directive 2011/65/EU	Compliant
EU ELV Directive 2000/53/EC	Compliant
China RoHS 2 Directive MIIT Order No 32, 2016	No Restricted Materials Above Threshold
EU REACH Regulation (EC) No. 1907/2006	Current ECHA Candidate List: JUNE 2022 (224) Candidate List Declared Against: JAN 2022 (223)



SVHC > Threshold:
Not Yet Reviewed

Halogen Content	Low Halogen - Br, Cl, F, I < 900 ppm per homogenous material. Also BFR/CFR/PVC Free
Solder Process Capability	Not applicable for solder process capability

Product Compliance Disclaimer

This information is provided based on reasonable inquiry of our suppliers and represents our current actual knowledge based on the information they provided. This information is subject to change. The part numbers that TE has identified as EU RoHS compliant have a maximum concentration of 0.1% by weight in homogenous materials for lead, hexavalent chromium, mercury, PBB, PBDE, DBP, BBP, DEHP, DIBP, and 0.01% for cadmium, or qualify for an exemption to these limits as defined in the Annexes of Directive 2011/65/EU (RoHS2). Finished electrical and electronic equipment products will be CE marked as required by Directive 2011/65/EU. Components may not be CE marked. Additionally, the part numbers that TE has identified as EU ELV compliant have a maximum concentration of 0.1% by weight in homogenous materials for lead, hexavalent chromium, and mercury, and 0.01% for cadmium, or qualify for an exemption to these limits as defined in the Annexes of Directive 2000/53/EC (ELV). Regarding the REACH Regulation, the information TE provides on SVHC in articles for this part number is based on the latest European Chemicals Agency (ECHA) 'Guidance on requirements for substances in articles' posted at this URL: <https://echa.europa.eu/guidance-documents/guidance-on-reach>

Compatible Parts

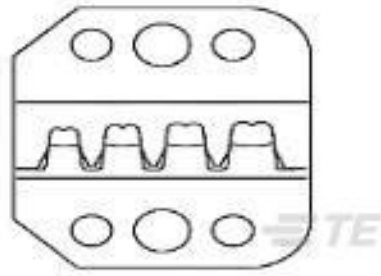

TE Part # 58630-2
PROCRRMP DIESET 12-10 ULTRAFAST



TE Part # 2-2151029-2
OCEAN_2.0_APPLICATOR-S-278D



TE Part # 2151029-2
OCEAN_2.0_APPLICATOR-S-278D

Also in the Series | Ultra-Fast 250



Quick Disconnects(49)

Customers Also Bought

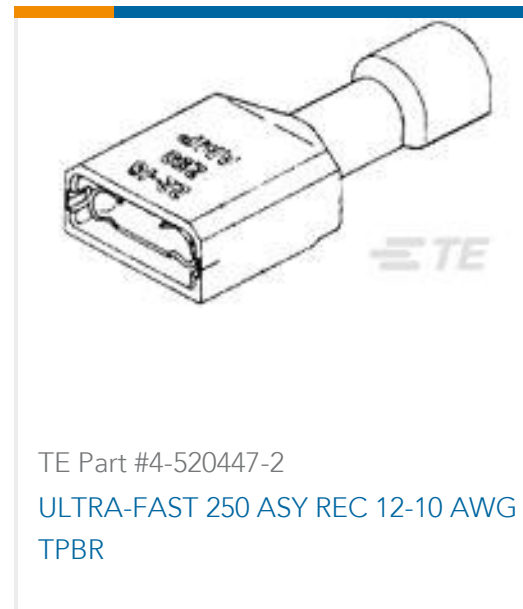
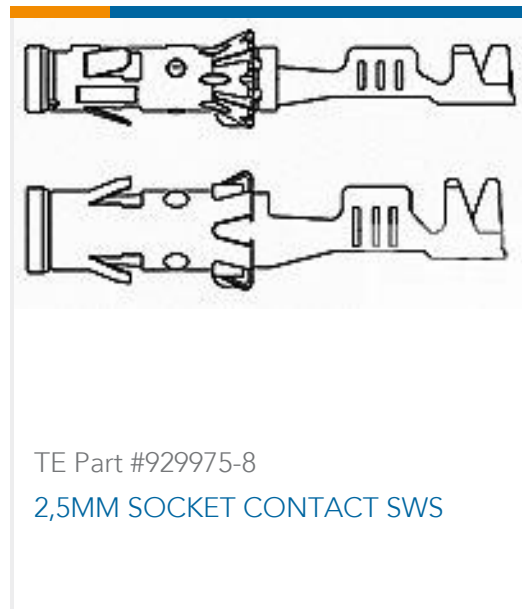

Documents

Product Drawings

[ULTRA-FAST 250 ASY TAB 12-10 AWG TPBR](#)

English

CAD Files

[3D PDF](#)

3D

Customer View Model

[ENG_CVM_CVM_4-521097-2_B.2d_dxf.zip](#)

English

Customer View Model

[ENG_CVM_CVM_4-521097-2_B.3d_igs.zip](#)

English

Customer View Model

[ENG_CVM_CVM_4-521097-2_B.3d_stp.zip](#)

English

By downloading the CAD file I accept and agree to the [Terms and Conditions](#) of use.

Datasheets & Catalog Pages



Ultra-Fast and Ultra Fast Plus

English

Product Specifications

Application Specification

English

Product Environmental Compliance

[MD_4-521097-2_01022018815_dmtec](#)

English

[MD_4-521097-2_01022018815_dmtec](#)

English

Agency Approvals

[UL](#)

English