

12 CIRCUIT VERTICAL HEADER
POLARIZATION OPTION A

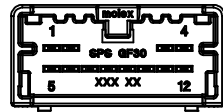

12 CIRCUIT VERTICAL HEADER
POLARIZATION OPTION B

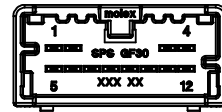

12 CIRCUIT VERTICAL HEADER
POLARIZATION OPTION C

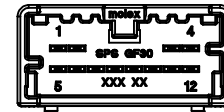

12 CIRCUIT VERTICAL HEADER
POLARIZATION OPTION D

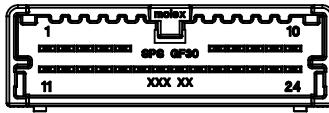

24 CIRCUIT VERTICAL HEADER
POLARIZATION OPTION A

NOT TOOLED

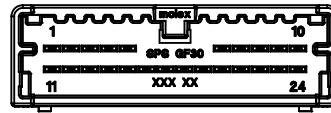

24 CIRCUIT VERTICAL HEADER
POLARIZATION OPTION B

NOT TOOLED

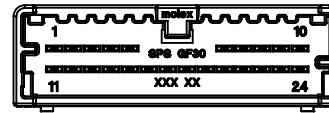

24 CIRCUIT VERTICAL HEADER
POLARIZATION OPTION C

NOT TOOLED

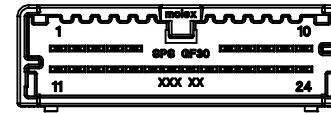

24 CIRCUIT VERTICAL HEADER
POLARIZATION OPTION D

NOT TOOLED

MINISO VERTICAL HEADER ASSEMBLIES

MATERIAL NUMBER TRAY PACKAGING PK-31301-688	CIRCUIT	POL	COLOR	BLADE PLATING	MATING COMPONENT
34825-0120	12	A	BLACK	TIN OVER NICKEL	34824-0120
34825-0121	12	B	GRAY	TIN OVER NICKEL	34824-0121
34825-0122	12	C	BROWN	TIN OVER NICKEL	34824-0122
34825-0123	12	D	GREEN	TIN OVER NICKEL	34824-0123
34825-0240 - NOT TOOLED	24	A	BLACK	TIN OVER NICKEL	34824-0240 - NOT TOOLED
34825-0241 - NOT TOOLED	24	B	GRAY	TIN OVER NICKEL	34824-0241 - NOT TOOLED
34825-0242 - NOT TOOLED	24	C	BROWN	TIN OVER NICKEL	34824-0242 - NOT TOOLED
34825-0243 - NOT TOOLED	24	D	GREEN	TIN OVER NICKEL	34824-0243 - NOT TOOLED

NOTES: VALID UNLESS OTHERWISE SPECIFIED

- GENERAL:
 - APPLICATION SPECIFICATION SEE: AS-34791-020
 - PRODUCT SPECIFICATION SEE: PS-34791-020
 - PACKAGING SPECIFICATION PER MOLEX DRAWING PK-31301-688
 - SOLDERABILITY PER SMES-152
 - PARTS MUST BE IN COMPLIANCE TO MOLEX CHEMICAL SUBSTANCES FOR PRODUCTS AND PACKAGING SPECIFICATION: OHS-699000-300
 - DATA MUST BE SUBMITTED UNDER THE MOLEX PART NUMBER TO IMDS (COMPANY ID:13255)
 - FLAMMABILITY REQUIREMENT: PER ISO3795 OR GM3191
 - VISUAL DEFECTS SHALL MEET COSMETIC STANDARD PS-45499-002 (Class B)
- DESIGN - MATERIALS:
 - SHROUD (PLASTIC HOUSING): SPS 30% GF, 20% REGRIND MAX PER WEIGHT
 - BLADES:
 - BASE METAL: C260 BRASS
 - PLATING REQUIREMENTS:
 - TIN OVER NICKEL:
 - UNDERPLATING:
 - OVERALL NICKEL
 - OVERPLATING:
 - OVERALL TIN
- DESIGN - GEOMETRY:
 - THIS IS A 100% CAD GENERATED PART. THE CAD MATHEMATICAL DATA IS THE MASTER FOR THIS PART. FOR DIMENSIONAL OR ANY INFORMATION NOT SHOWN ON THIS DRAWING, ANALYZE THE CAD MODEL.
 - GEOMETRIC DIMENSIONS AND TOLERANCES PER ASME Y14.5M - 1994
 - GENERAL TOLERANCES: SEE TITLE BLOCK
 - EDGES AND UNDIMENSIONED DETAILS PER ISO13715
 - CORNERS SHOWN AS SHARP TO BE R 0.1 MAX
 - LETTERS SHALL BE 0.10 MAX RAISED. THIS INCLUDES RECYCLING CODE, PLANT AND CAVITY ID, VENDOR ID, AND CIRCUIT ID.

LAST BALLOON ON DRAWING:
⑥
DELETED BALLOONS:

INITIAL RELEASE EC NO. UAU2011-1023 DRAWING NO. 2011/02/25 APPR: SMARCEAU REV: 2011/05/18	QUALITY SYMBOLS	GENERAL TOLERANCES (UNLESS SPECIFIED)	DIMENSION STYLE	SCALE	DESIGN UNITS	THIRD ANGLE PROJECTION	
	$\nabla=0$ $\nabla=0$ $\nabla=0$	mm INCH 4 PLACES ± --- ± --- 3 PLACES ± --- ± --- 2 PLACES ± 0.10 ± --- 1 PLACE ± 0.20 ± --- ANGULAR ± 3°	mm ONLY DRAWN BY DATE TUCUCU 2011/02/25 CHECKED BY DATE TMACHUGA 2011/02/28 APPROVED BY DATE SMARCEAU 2011/05/18	5:1	METRIC		
	DRAFT WHERE APPLICABLE MUST REMAIN WITHIN DIMENSIONS		SEE TABLE		DOCUMENT NO. SD-34825-000		SHEET NO. 1 OF 2
	THIS DRAWING CONTAINS INFORMATION THAT IS PROPRIETARY TO MOLEX, INCORPORATED AND SHOULD NOT BE USED WITHOUT WRITTEN PERMISSION						

12 CIRCUIT VERTICAL HEADER

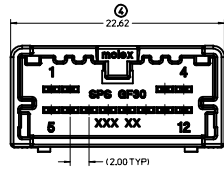
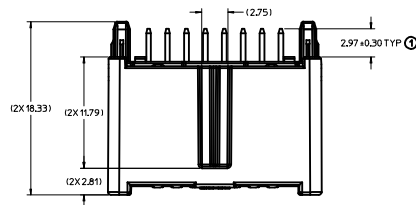

24 CIRCUIT VERTICAL HEADER

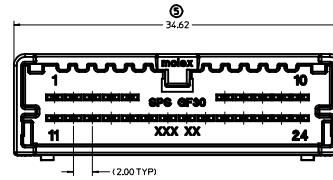
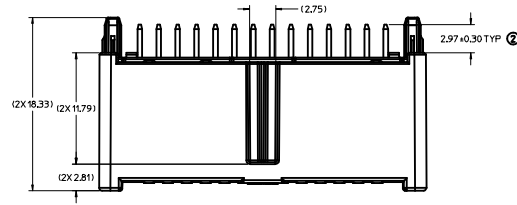

HEADER TO PCB FLUSH MOUNT

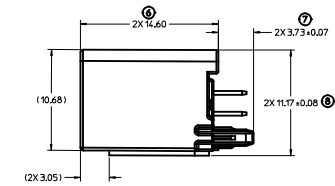
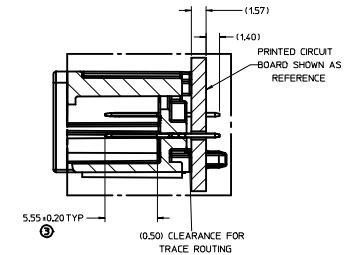

PCB LAYOUT CONNECTOR MATE SIDE

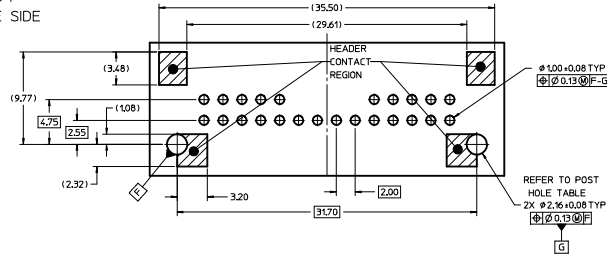
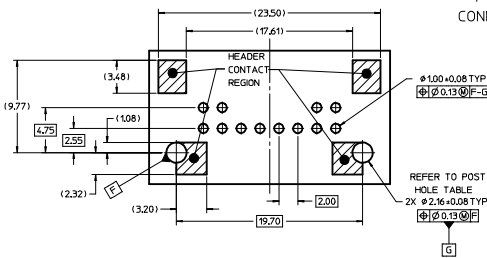

POST HOLE TABLE

	DM 'E'
PRESS FIT	2.15
DROP IN	2.55

INITIAL RELEASE EC NO. UAU2011-1023 DRAWN TO CO 2011/02/25 APPR. SMARCEAU 2011/05/18	QUALITY SYMBOLS ▽=0 ▽=0 ▽=0	GENERAL TOLERANCES (UNLESS SPECIFIED) mm INCH 4 PLACES ± .005 ± .002 3 PLACES ± .010 ± .004 2 PLACES ± .020 ± .008 1 PLACE ± .050 ± .020 ANGULAR ± 3°	DIMENSION STYLE MM ONLY DRAWN BY DATE TUCUCU 2011/02/25 CHECKED BY DATE TMACHUGA 2011/02/28 APPROVED BY DATE SMARCEAU 2011/05/18	SCALE 5:1 DESIGN UNITS METRIC THIRD ANGLE PROJECTION	MATERIAL NO. DOCUMENT NO. SD-34825-000	SHEET NO. 2 OF 2
	DRAFT WHERE APPLICABLE MUST REMAIN WITHIN DIMENSIONS			SEE TABLE		
	THIS DRAWING CONTAINS INFORMATION THAT IS PROPRIETARY TO MOLEX INCORPORATED AND SHOULD NOT BE USED WITHOUT WRITTEN PERMISSION					
	MOLEX MOLEX INCORPORATED					

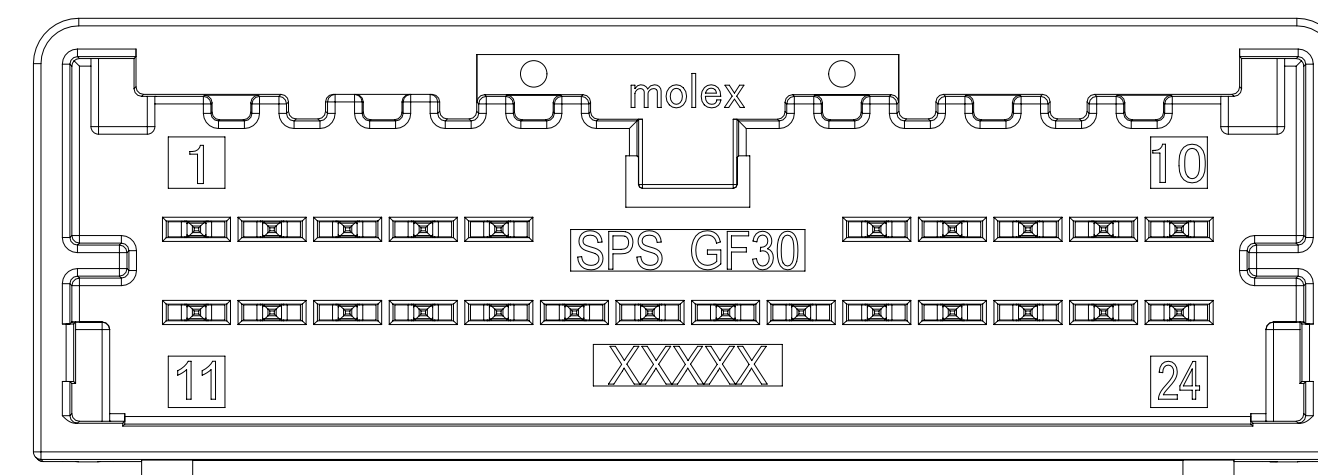
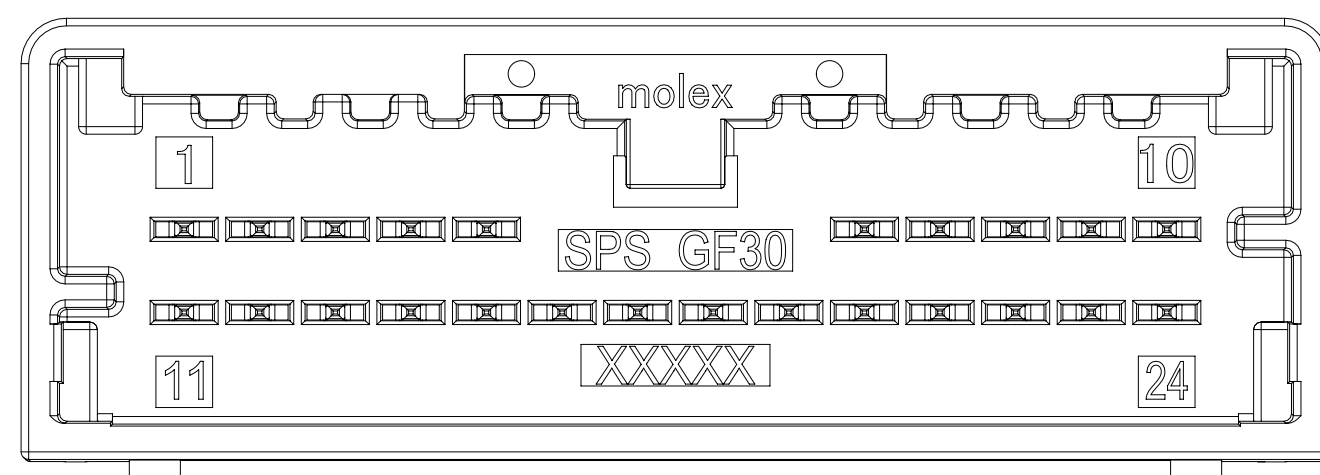
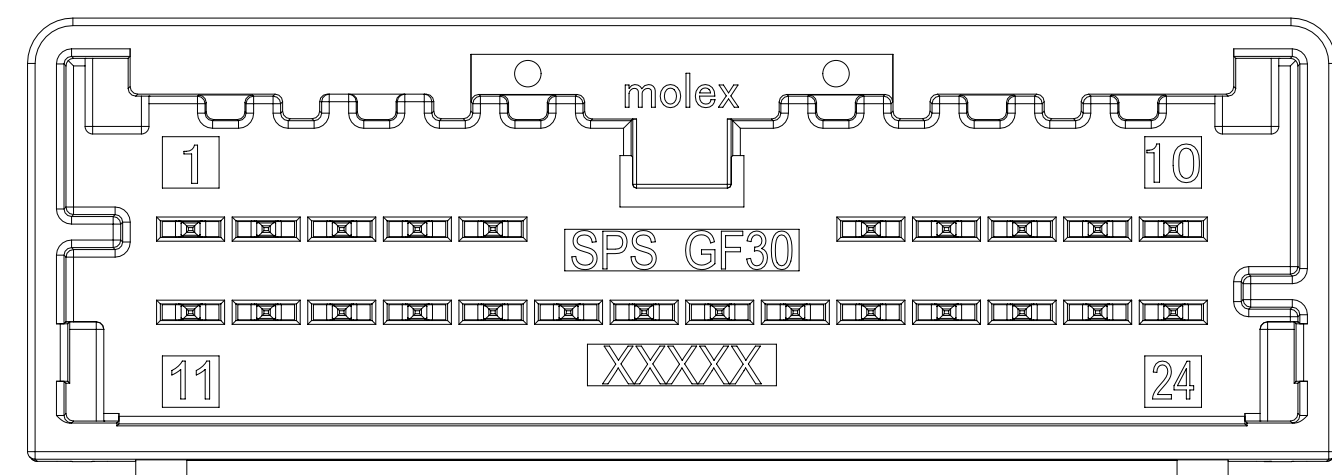
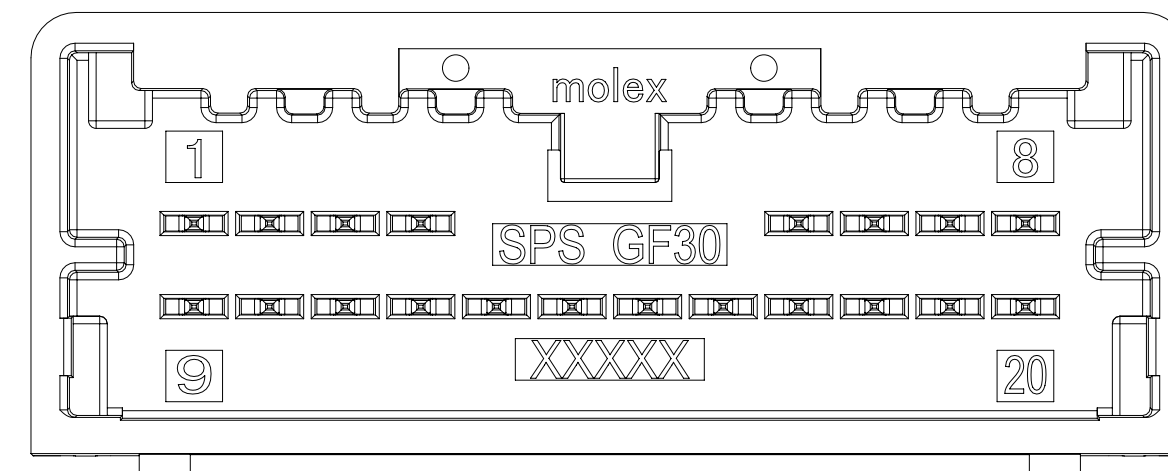
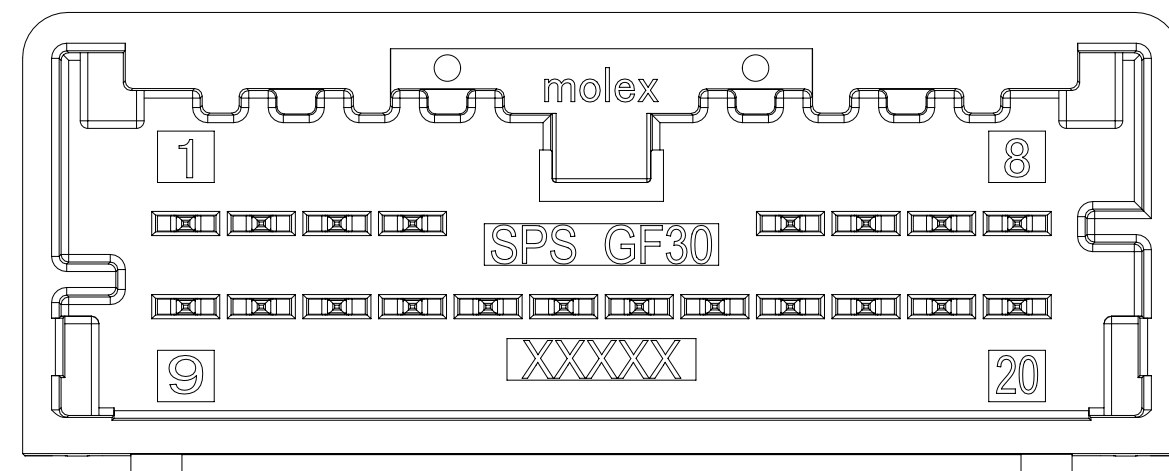
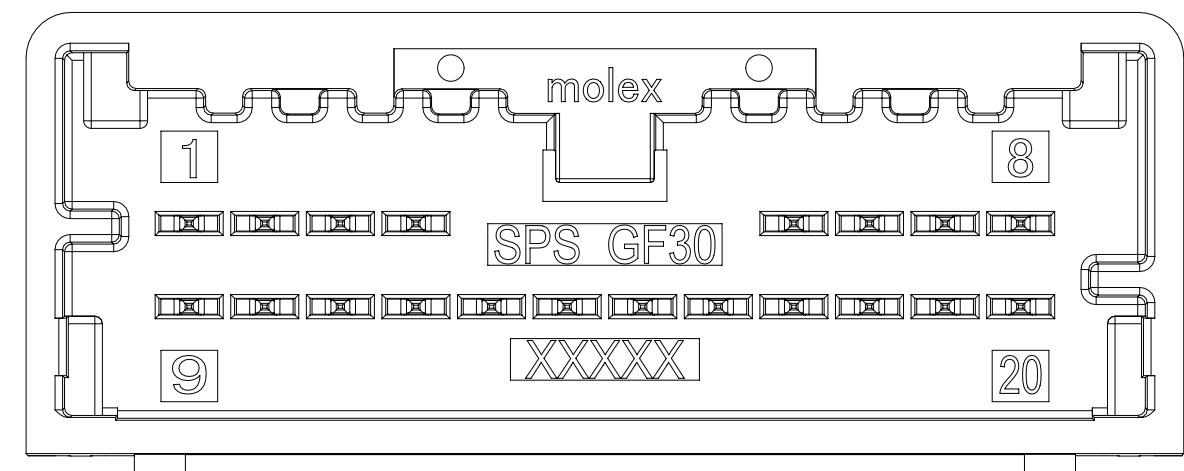
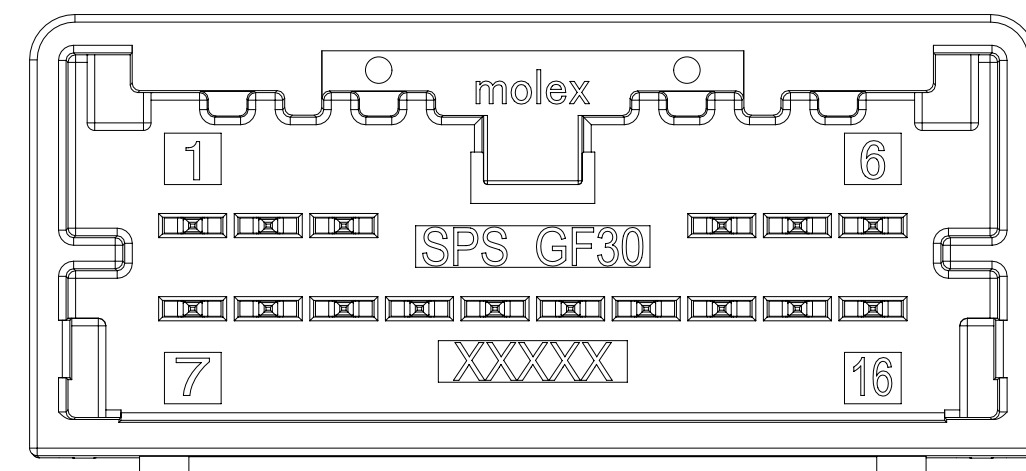
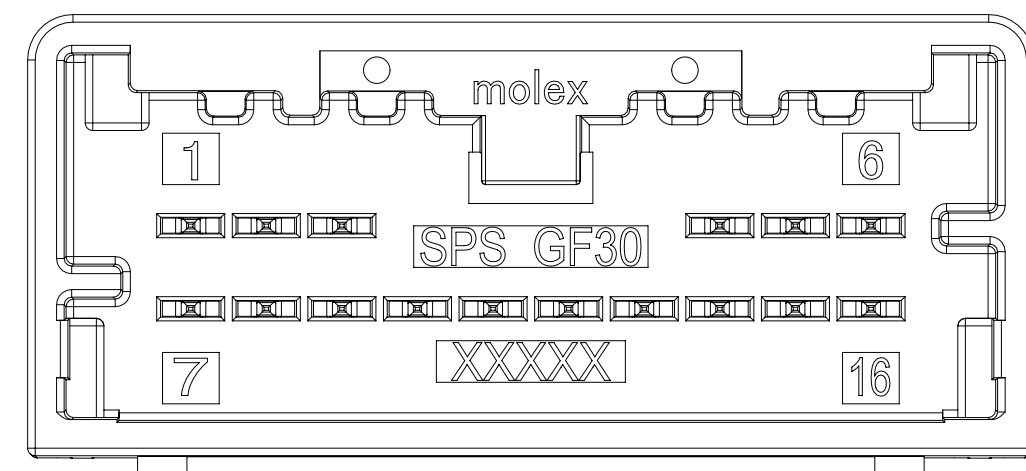
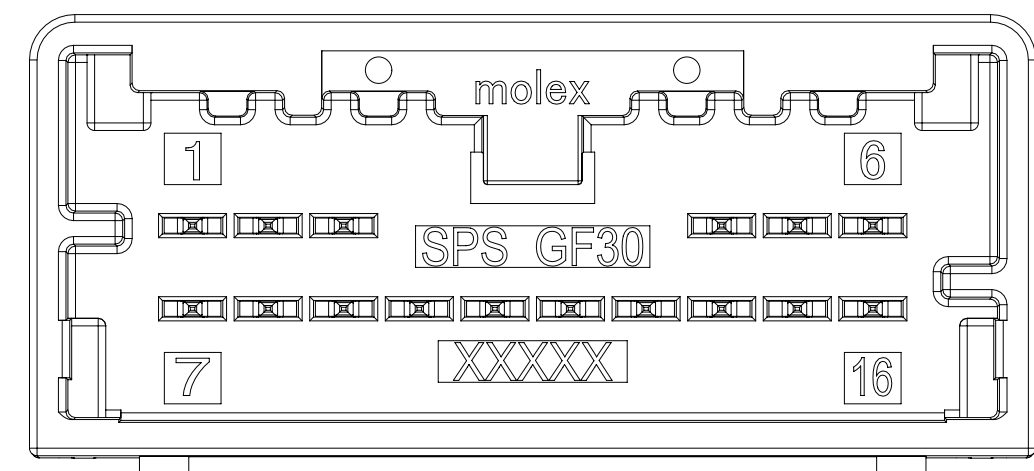
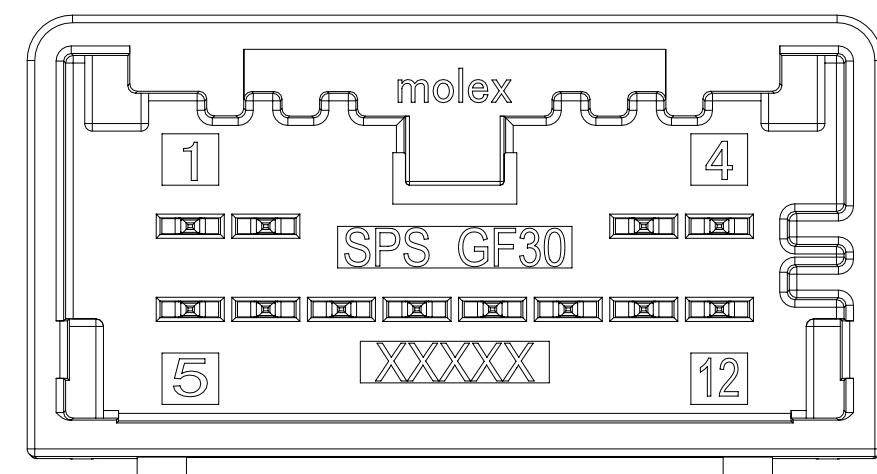
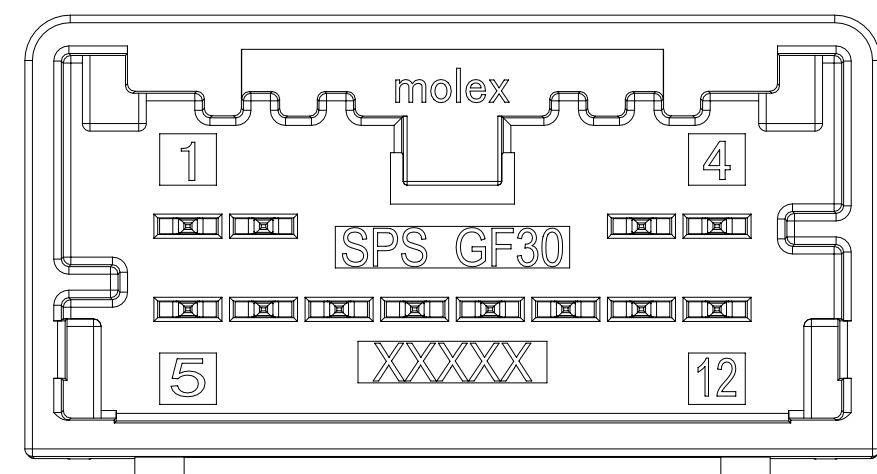
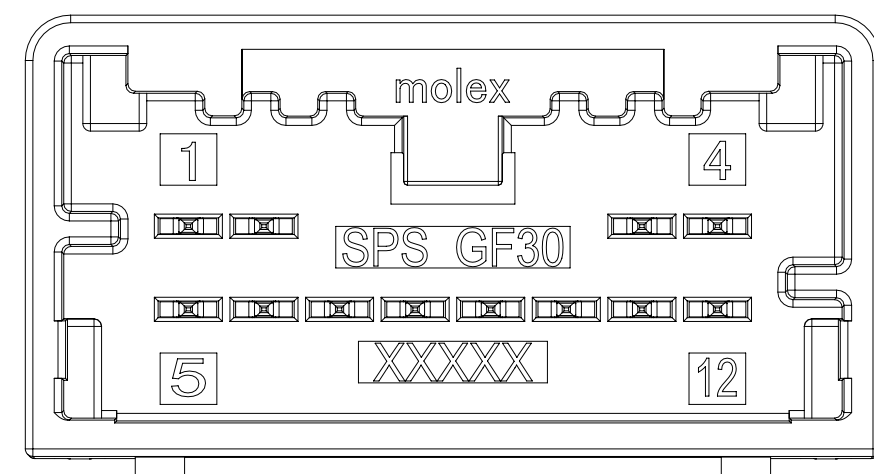

NOTES: VALID UNLESS OTHERWISE SPECIFIED

1. GENERAL:
 - a. APPLICATION SPECIFICATION SEE: AS-34791-020
 - b. PRODUCT SPECIFICATION SEE: PS-34791-020
 - c. PACKAGING SPECIFICATION PER MOLEX DRAWING: SEE CHART
 - d. SOLDERABILITY PER SMES-152
 - e. PARTS MUST BE IN COMPLIANCE TO MOLEX CHEMICAL SUBSTANCES FOR PRODUCTS AND PACKAGING SPECIFICATION: QEHS-699000-300
 - f. DATA MUST BE SUBMITTED UNDER THE MOLEX PART NUMBER TO IMDS (COMPANY ID#13255)
 - g. FLAMMABILITY REQUIREMENT: PER ISO3795 OR GM3191
 - h. VISUAL DEFECTS SHALL MEET COSMETIC STANDARD PS-45499-002 (Class B)
2. DESIGN - MATERIALS:
 - a. SHROUD (PLASTIC HOUSING): SPS 30% GF, 20% REGRIND MAX PER WEIGHT
 - b. BLADES:
 - BASE METAL: C260 BRASS
 - PLATING REQUIREMENTS:
 - TIN OVER NICKEL:
 - UNDERPLATING:
 - OVERALL NICKEL
 - OVERPLATING:
 - OVERALL TIN
3. DESIGN - GEOMETRY:
 - a. THIS IS A 100% CAD GENERATED PART. THE CAD MATHEMATICAL DATA IS THE MASTER FOR THIS PART. FOR DIMENSIONAL OR ANY INFORMATION NOT SHOWN ON THIS DRAWING, ANALYZE THE CAD MODEL.
 - b. GEOMETRIC DIMENSIONS AND TOLERANCES PER ASME Y14.5M - 2009
 - c. GENERAL TOLERANCES: SEE TITLE BLOCK
 - d. EDGES AND UNDIMENSIONED DETAILS PER ISO13715
 - e. CORNERS SHOWN AS SHARP TO BE R 0.1 MAX
 - f. LETTERING SHALL BE 0.10 MAX RAISED. THIS INCLUDES RECYCLING CODE, PLANT AND CAVITY ID, VENDOR ID, AND CIRCUIT ID.
 - g. USCAR INTERFACE:
 - 12 WAY: 050-U-012-2-ZXX
 - 16 WAY: 050-U-016-2-ZXX
 - 20 WAY: 050-U-020-2-ZXX
 - 24 WAY: 050-U-024-2-ZXX

INSPECTION BALLON NUMBER LOG
 PER DRAWING REVISION: H1
 LAST BALLON USED: 20
 ADDED BALLOON NUMBERS: 19, 20
 REMOVED BALLOON NUMBERS: 1, 2, 3, 4, 5, 6

H1	ADDED NOTE 3g TO SHEET 1
H	DRAWING REMASTERED UPDATED VIEWS TO MATCH PRODUCTION CHANGE. NO DIMENSIONAL OR GEOMETRY CHANGES. PAGE 4&5: ADDED P/N 348258207 TO TABLES
G3	UPDATED VIEWS TO MATCH CURRENT PRODUCTION. DIMS AND GEOMETRY DID NOT CHANGE
G2	ADDED NOTE AND PIN TP TO SHEET 2
G1	NX REMASTERING
REV	DESCRIPTION

THIS DRAWING CONTAINS INFORMATION THAT IS PROPRIETARY TO MOLEX ELECTRONIC TECHNOLOGIES, LLC AND SHOULD NOT BE USED WITHOUT WRITTEN PERMISSION		CURRENT REV DESC:			
DIMENSION UNITS	SCALE	EC NO: 638521 DRWN: SRUSS 2020/05/28 CHK'D: KHEWITT 2020/05/28 APPR: JDUNAJ 2020/05/29 INITIAL REVISION: DRWN: TMACHUGA 2012/05/03 APPR: SMARCEAU 2012/05/03			
mm	5:1	GENERAL TOLERANCES (UNLESS SPECIFIED)		MINI50 12-24CKT VERT HDR SALES DRAWING	
ANGULAR TOL	± 3.0°	4 PLACES ±		PRODUCT CUSTOMER DRAWING	
		3 PLACES ±		DOCUMENT NUMBER	
		2 PLACES ± 0.1		SD-34825-001	
		1 PLACE ± 0.2		DOC TYPE	
		0 PLACES ±		PSD	
DRAFT WHERE APPLICABLE MUST REMAIN WITHIN DIMENSIONS		THIRD ANGLE PROJECTION		DOC PART	
		DRAWING		001	
		SERIES		REVISION	
		D-SIZE		H1	
		34825			
		MATERIAL NUMBER		CUSTOMER	
		GENERAL MARKET		SHEET NUMBER	
				1 OF 5	

12 CIRCUIT

16 CIRCUIT

20 CIRCUIT

24 CIRCUIT

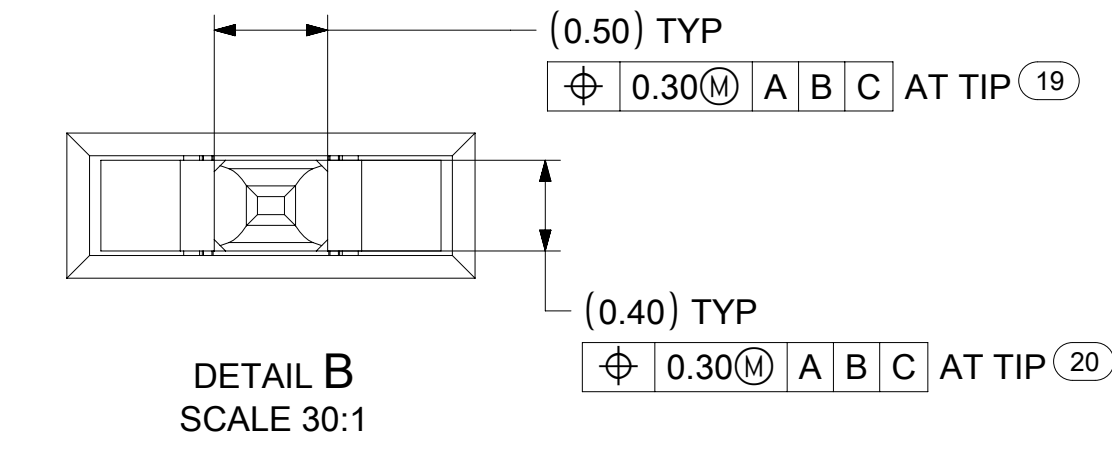
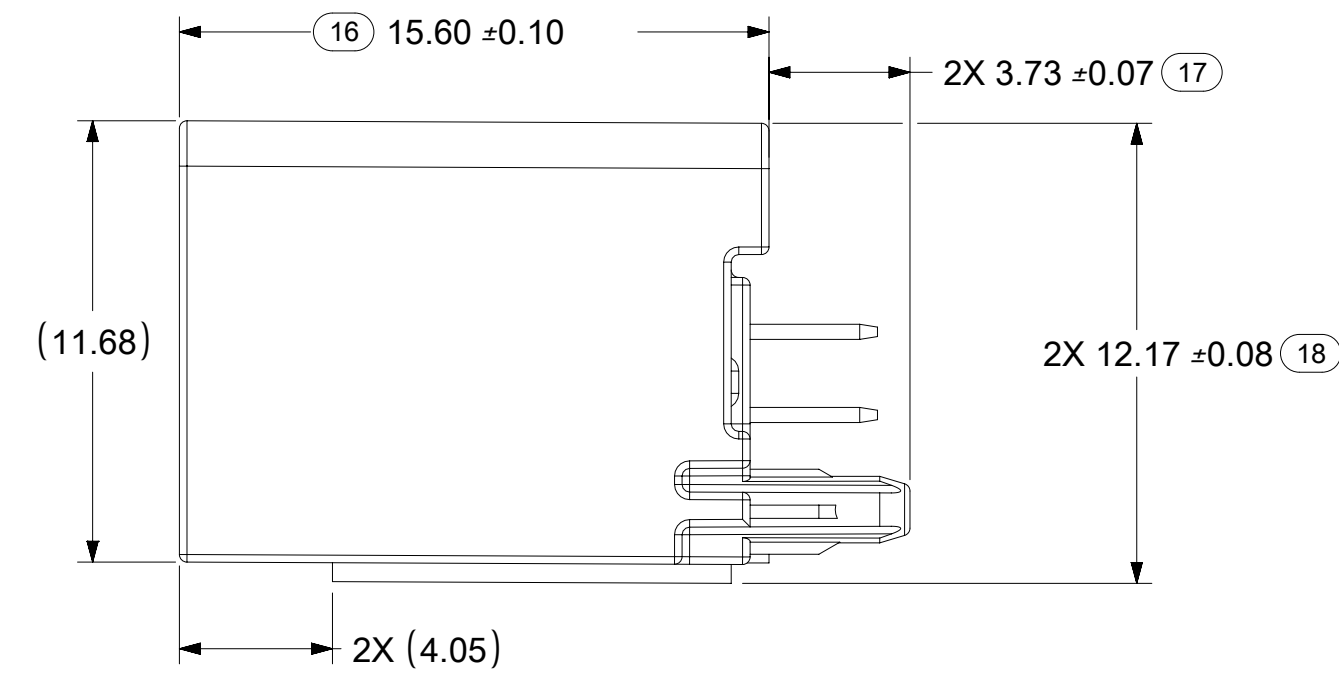
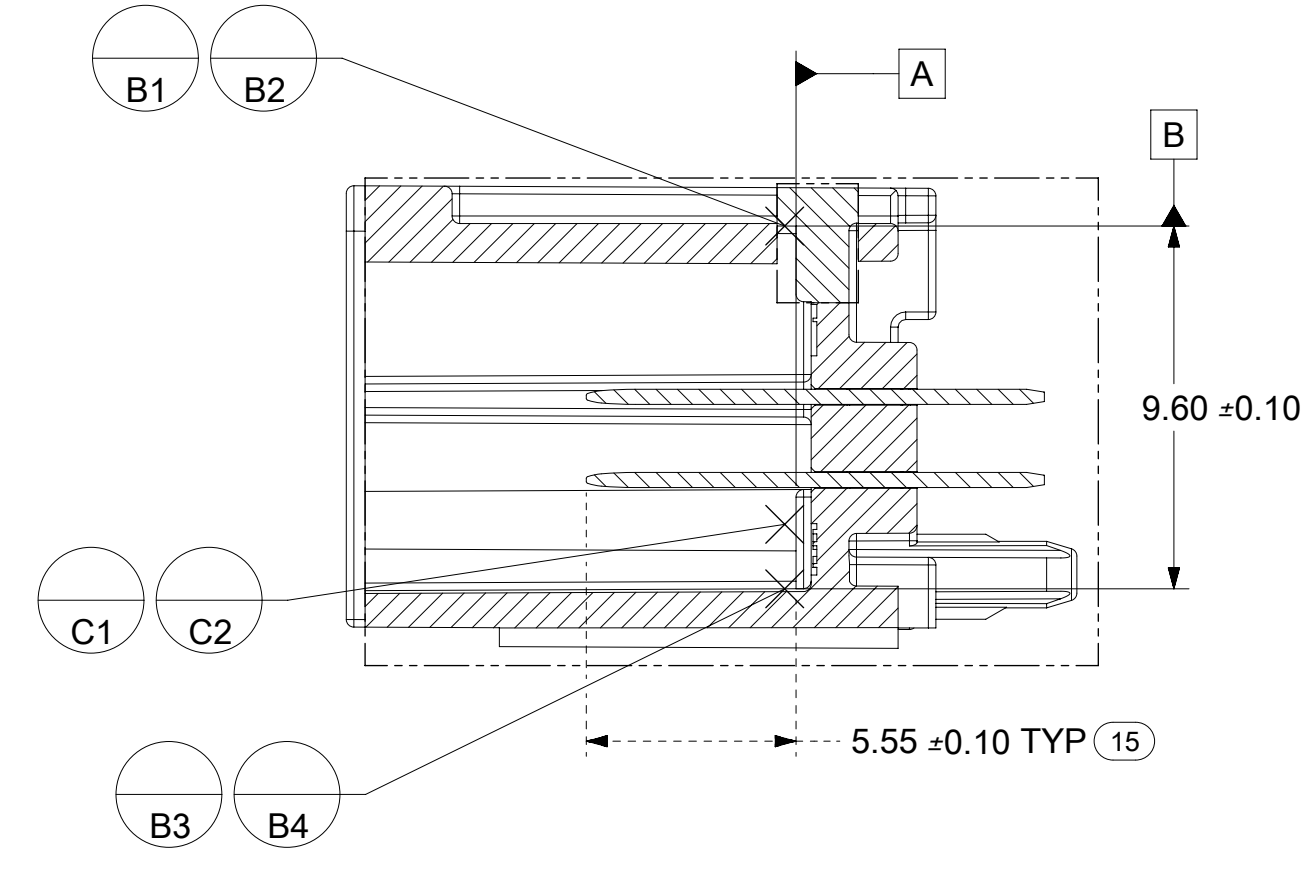
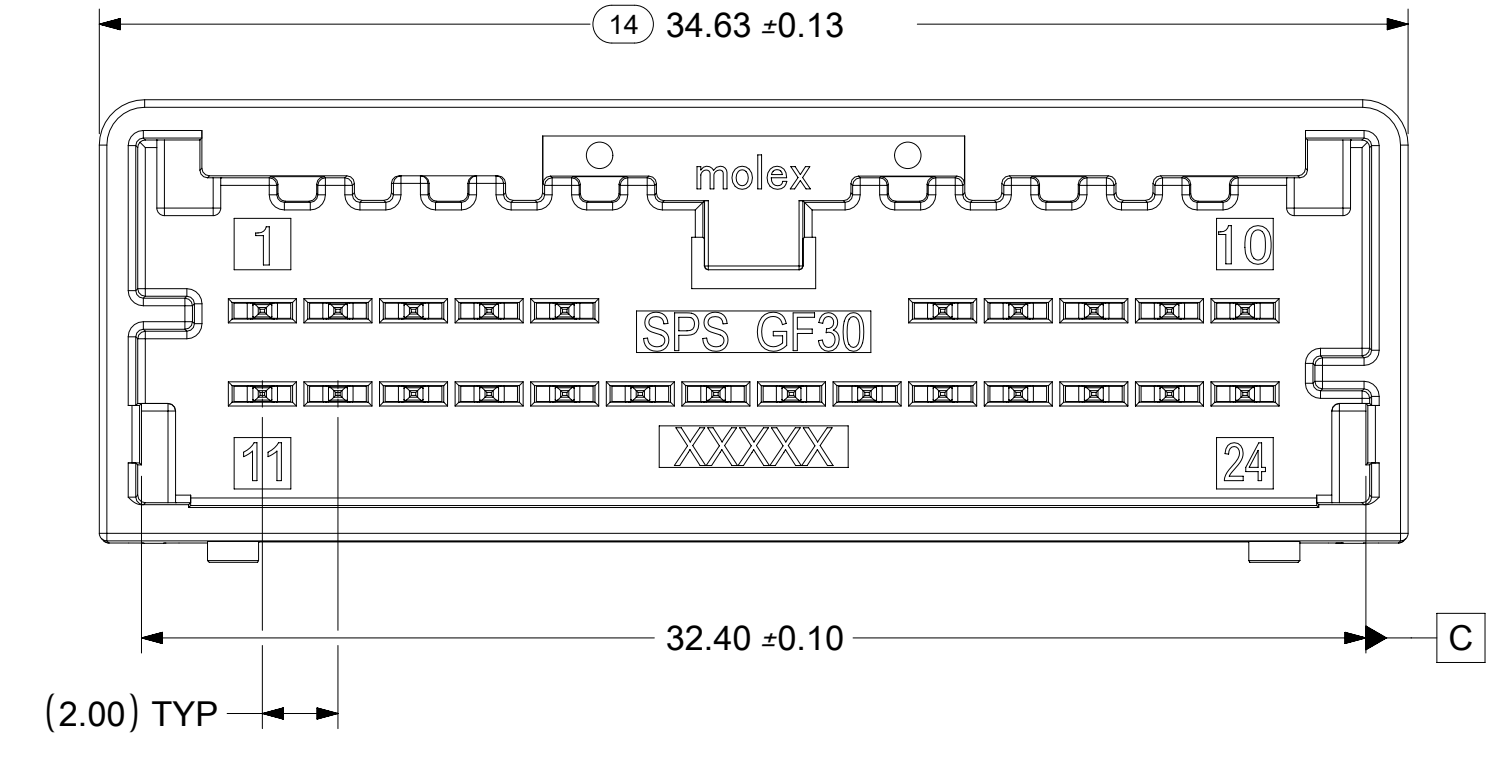
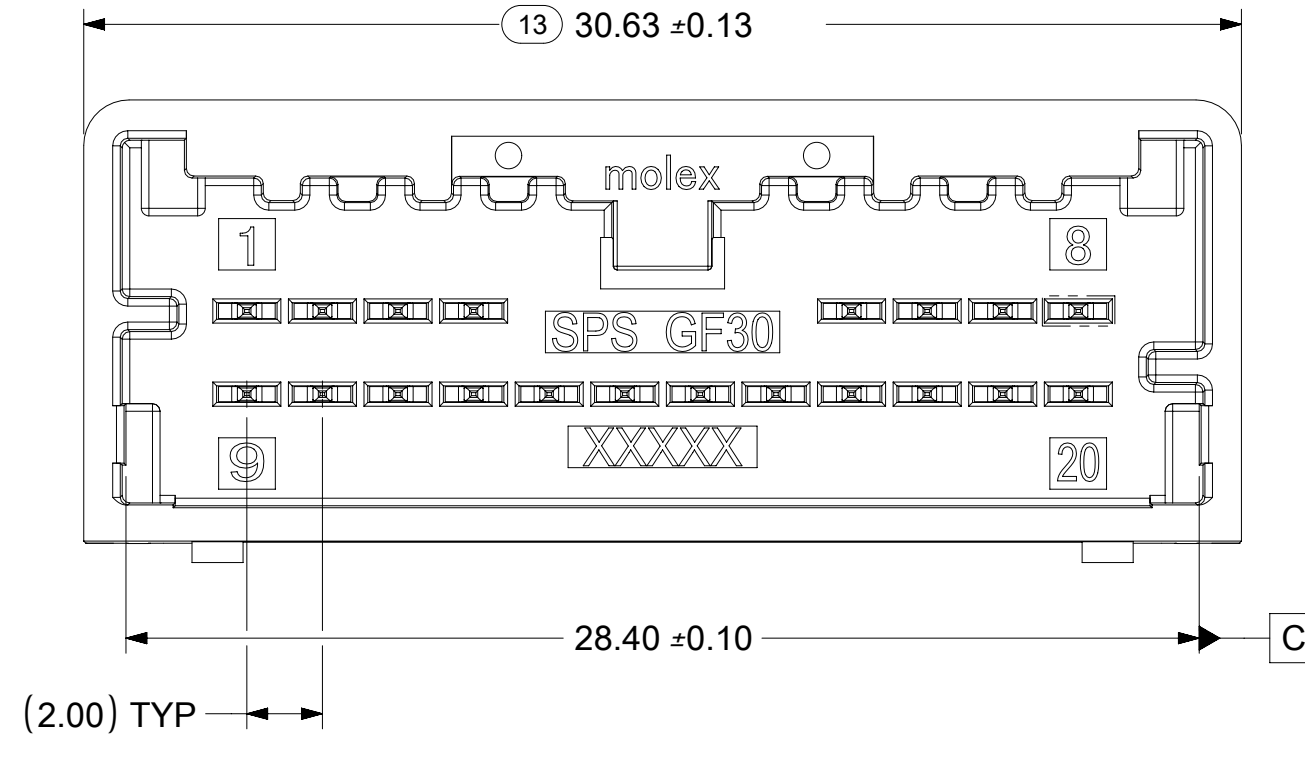
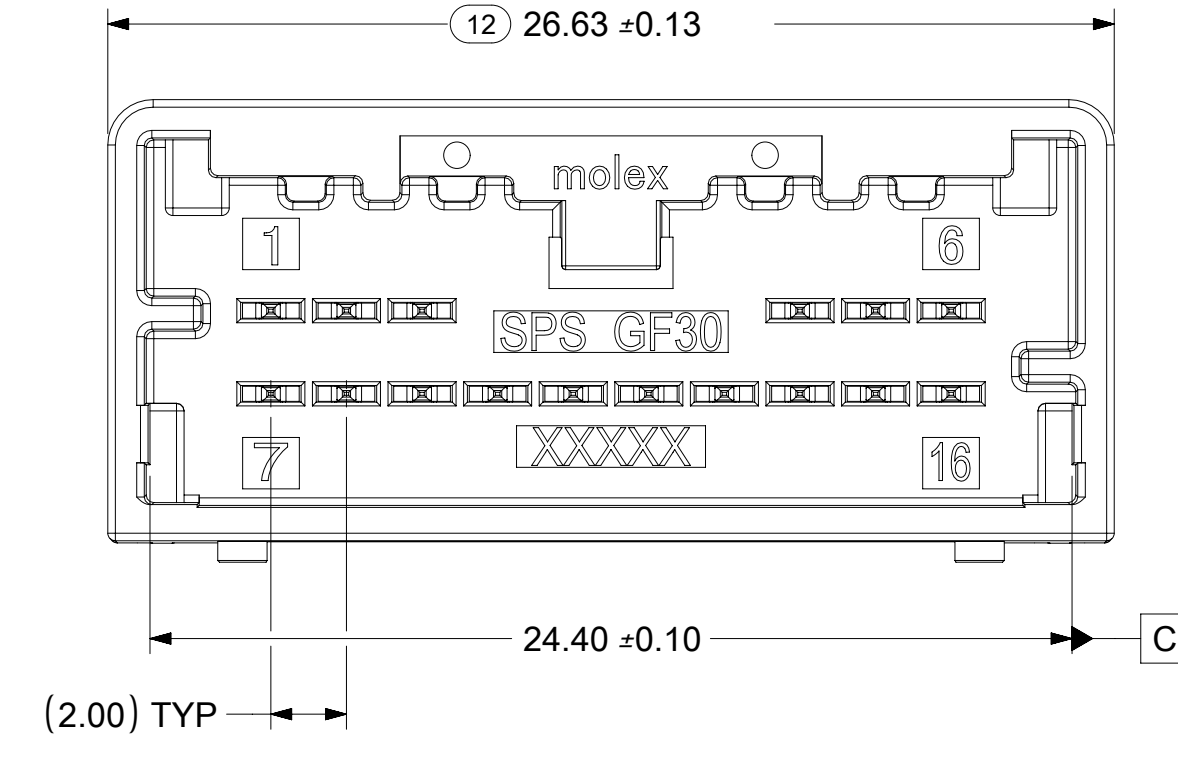
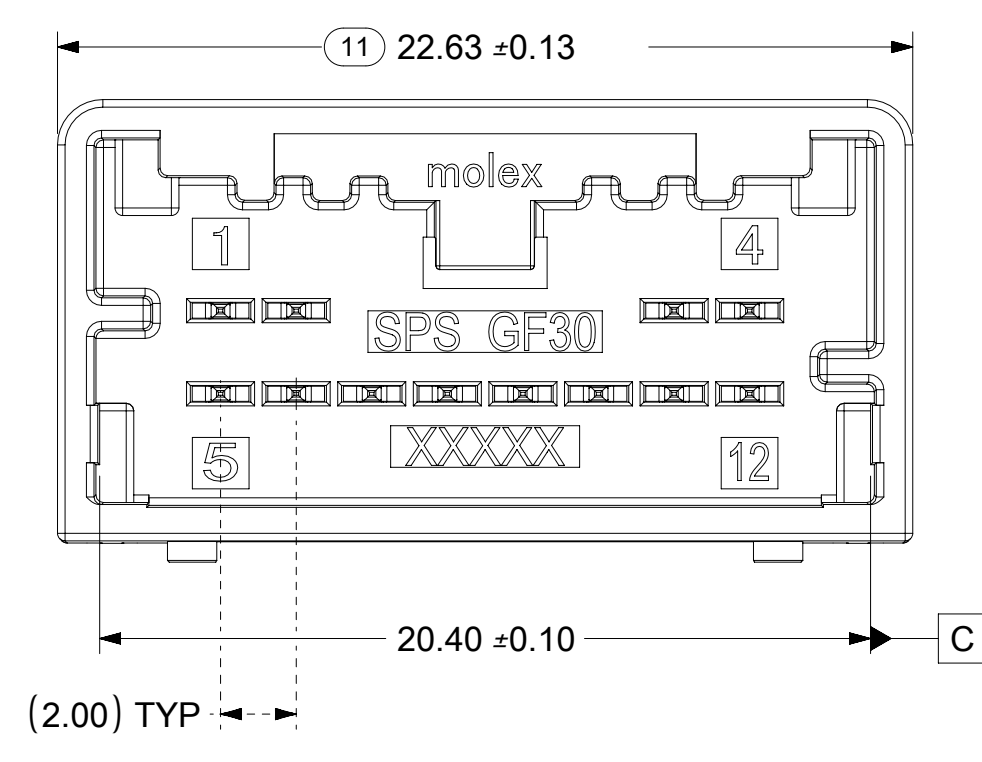
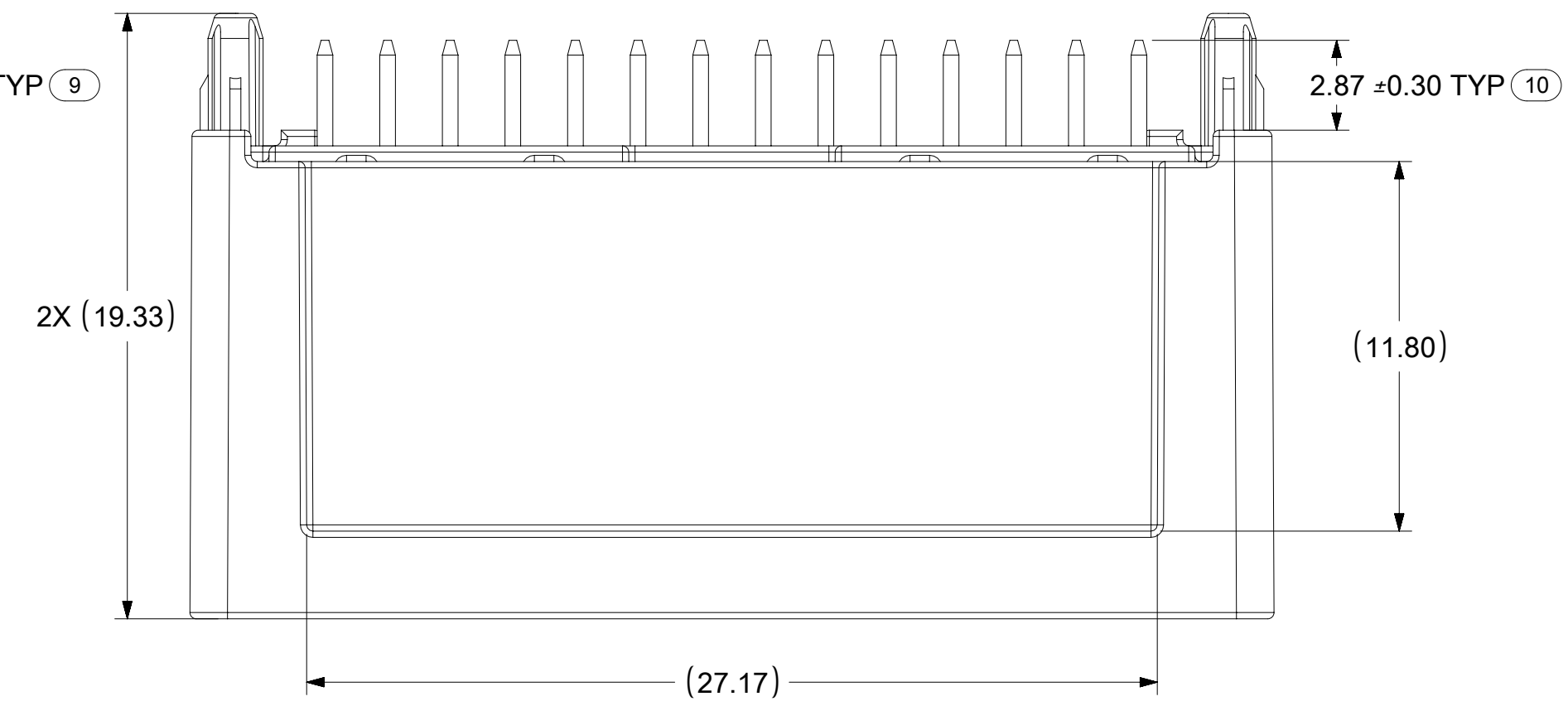
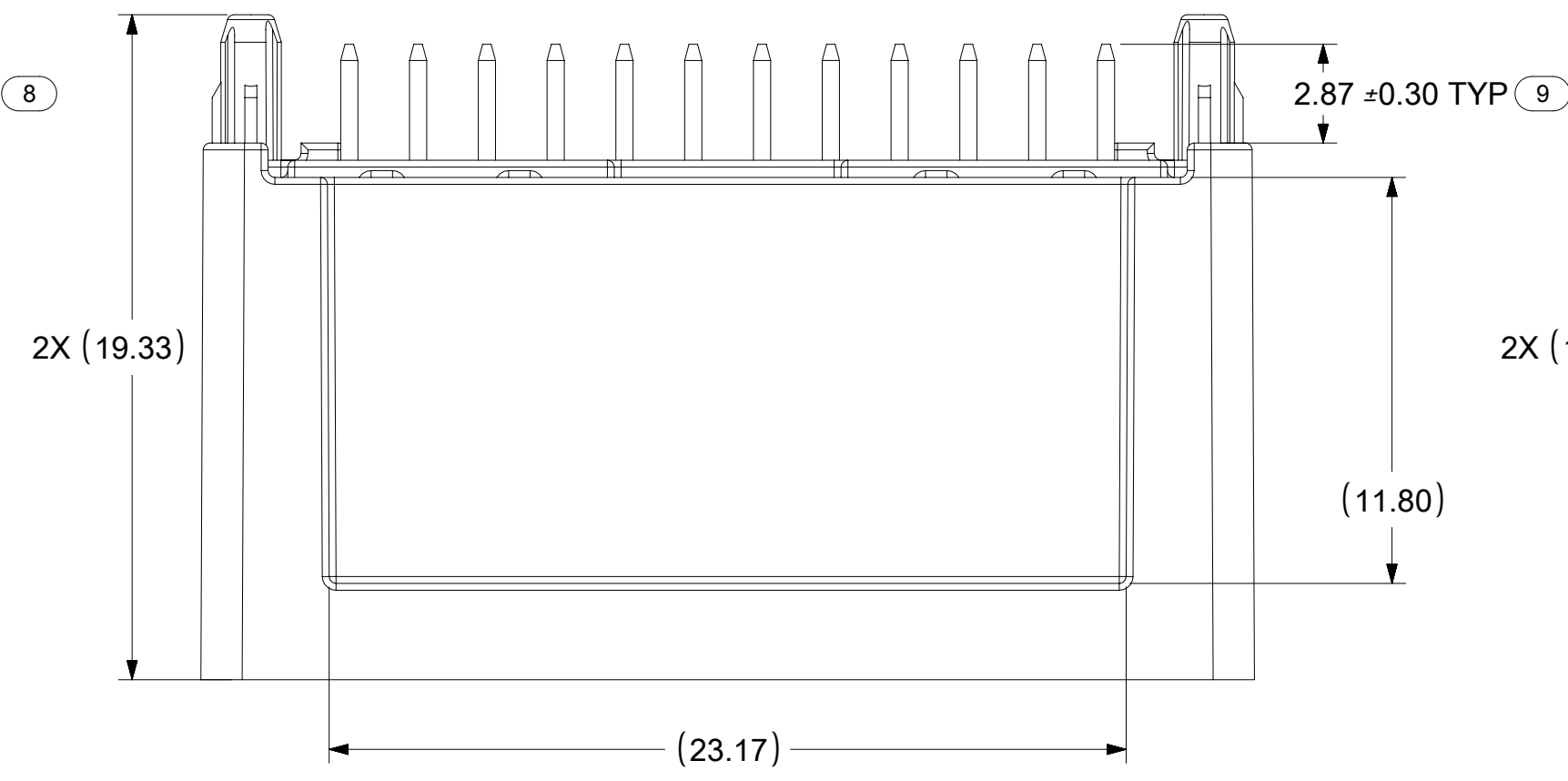
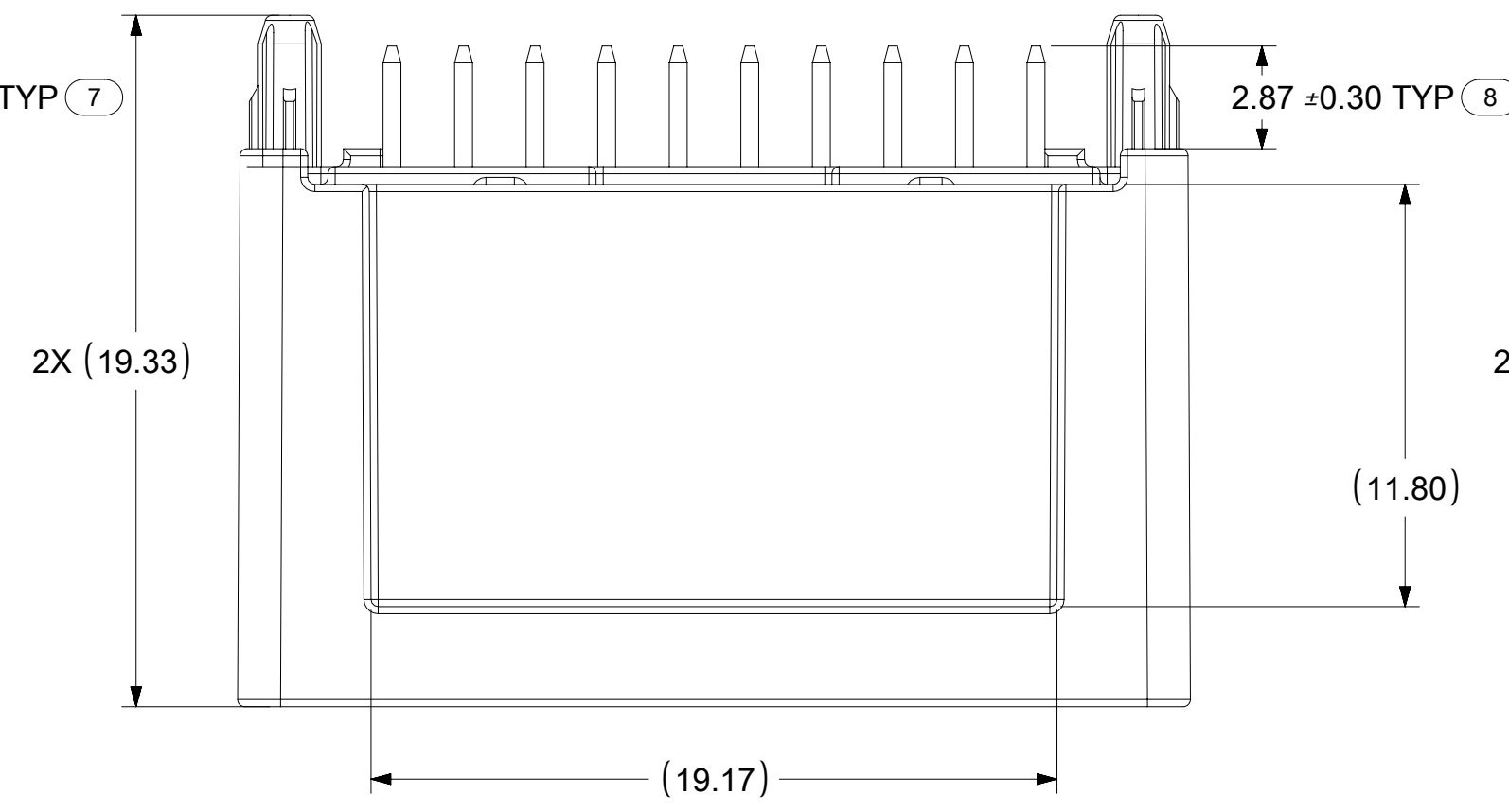
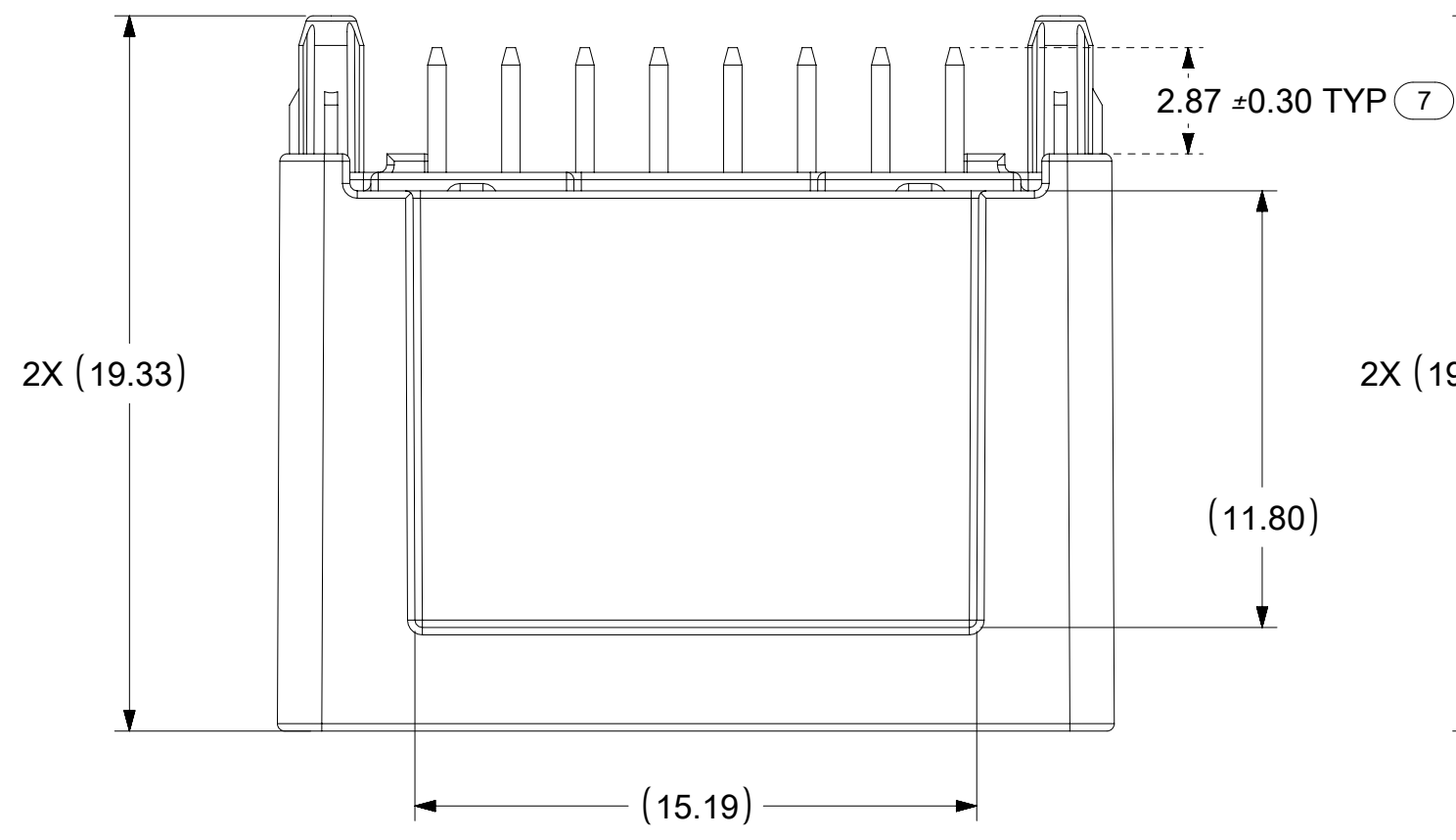

(18)

THIS DRAWING CONTAINS INFORMATION THAT IS PROPRIETARY TO MOLEX ELECTRONIC TECHNOLOGIES, LLC AND SHOULD NOT BE USED WITHOUT WRITTEN PERMISSION									
DIMENSION UNITS		SCALE		CURRENT REV DESC:					
mm		5:1							
GENERAL TOLERANCES (UNLESS SPECIFIED)				EC NO: 638521					
ANGULAR TOL ± 3.0°				DRWN: SRUSS 2020/05/28					
4 PLACES ±				CHK'D: KHEWITT 2020/05/28					
3 PLACES ±				APPR: JDUNAJ 2020/05/29					
2 PLACES ± 0.1				INITIAL REVISION:					
1 PLACE ± 0.2				DRWN: TMACHUGA 2012/05/03					
0 PLACES ±				APPR: SMARCEAU 2012/05/03					
DRAFT WHERE APPLICABLE MUST REMAIN WITHIN DIMENSIONS		THIRD ANGLE PROJECTION		DRAWING		SERIES		MATERIAL NUMBER	
				D-SIZE		34825		GENERAL MARKET	
				CUSTOMER		SHEET NUMBER			
						2 OF 5			

molex

MINI50 12-24CKT VERT HDR SALES DRAWING

PRODUCT CUSTOMER DRAWING

DOCUMENT NUMBER	DOC TYPE	DOC PART	REVISION
SD-34825-001	PSD	001	H1

DOCUMENT STATUS	P1	RELEASE DATE	2020/05/29 14:06:48
-----------------	----	--------------	---------------------

PCB LAYOUT

BOARD SHOWN FOR REFERENCE ONLY

POST HOLE TABLE

	DIM E
PRESS FIT	2.15
DROP IN	2.55

12 CIRCUIT

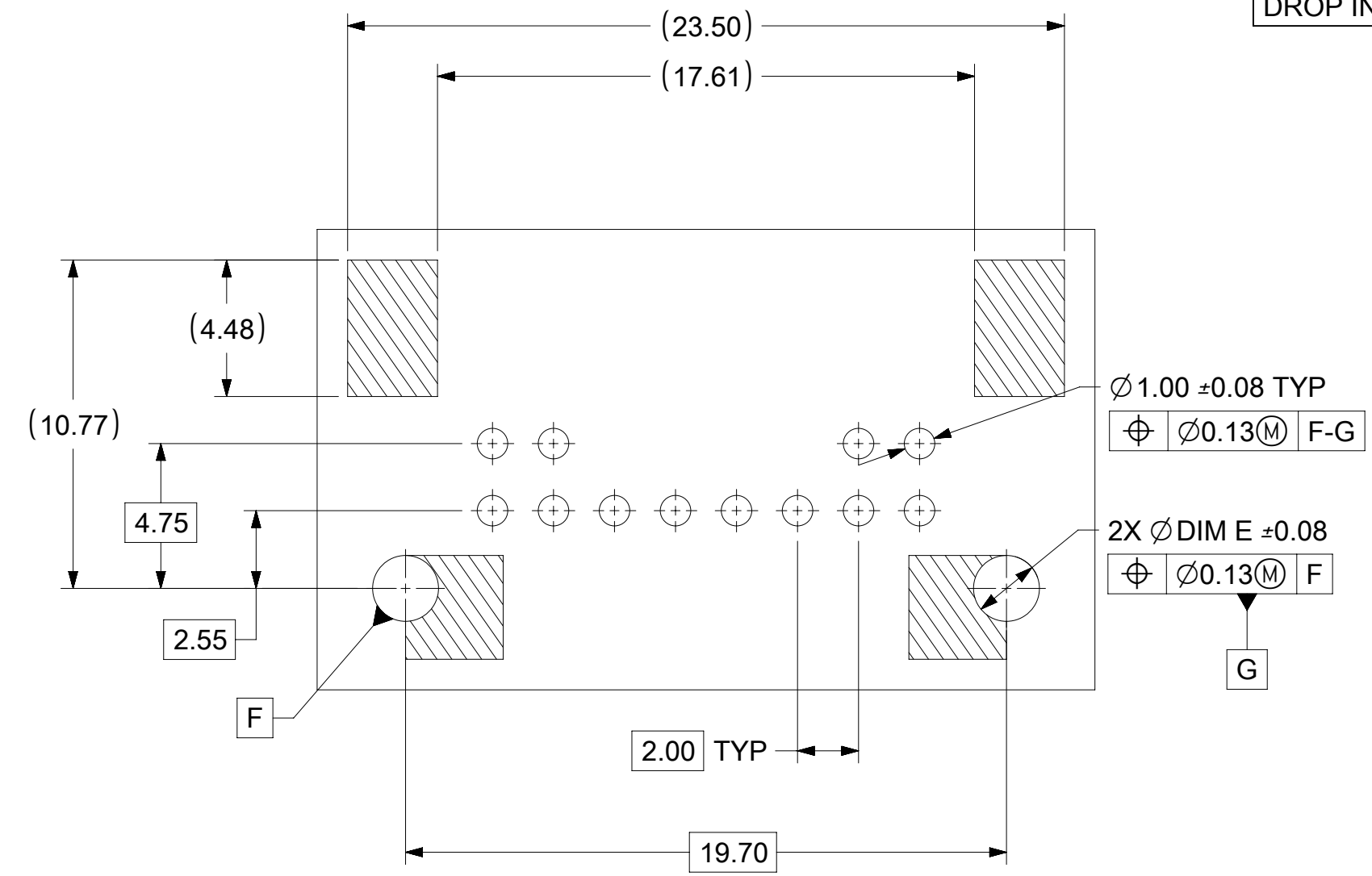

16 CIRCUIT

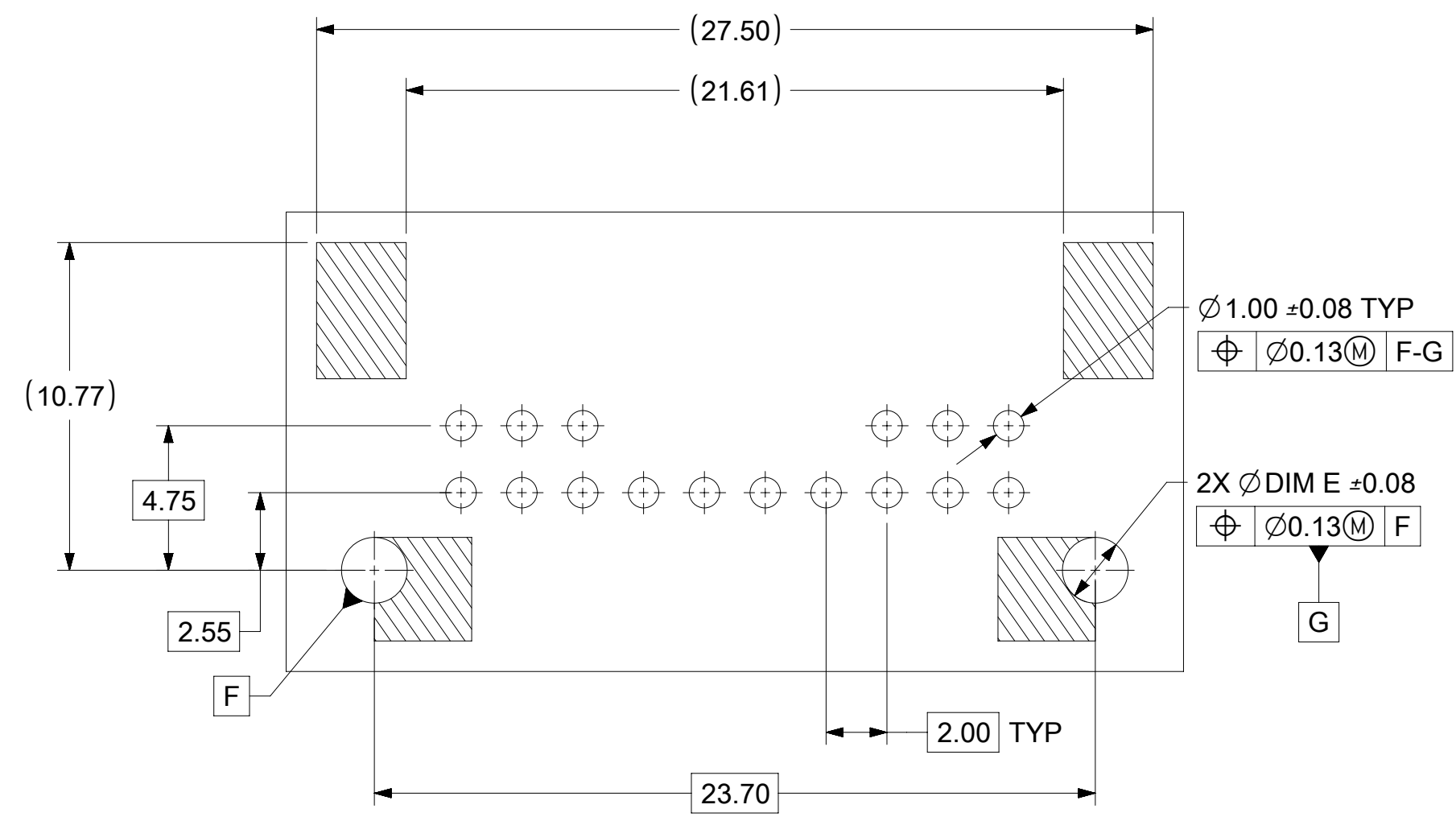

20 CIRCUIT

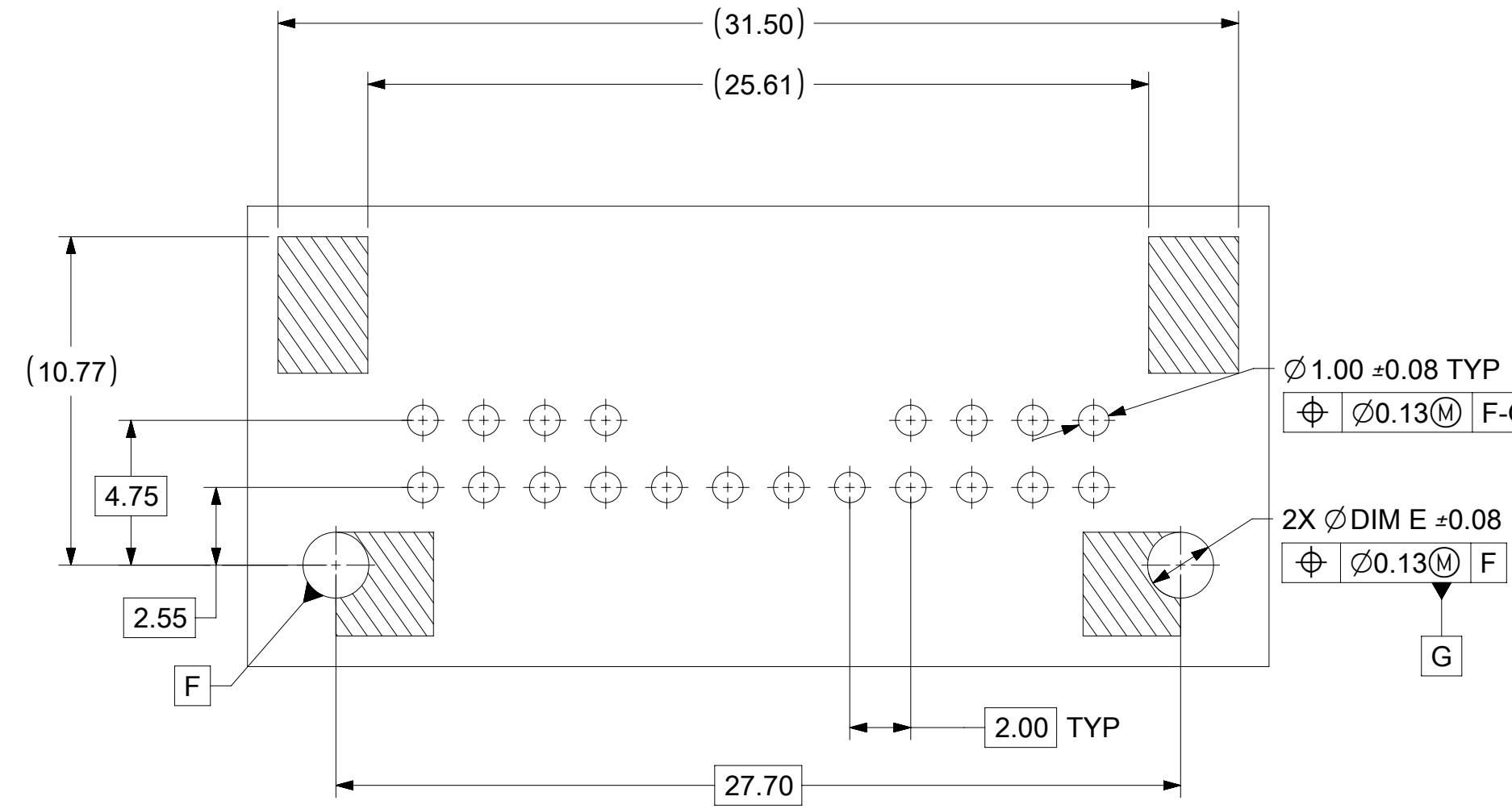

24 CIRCUIT

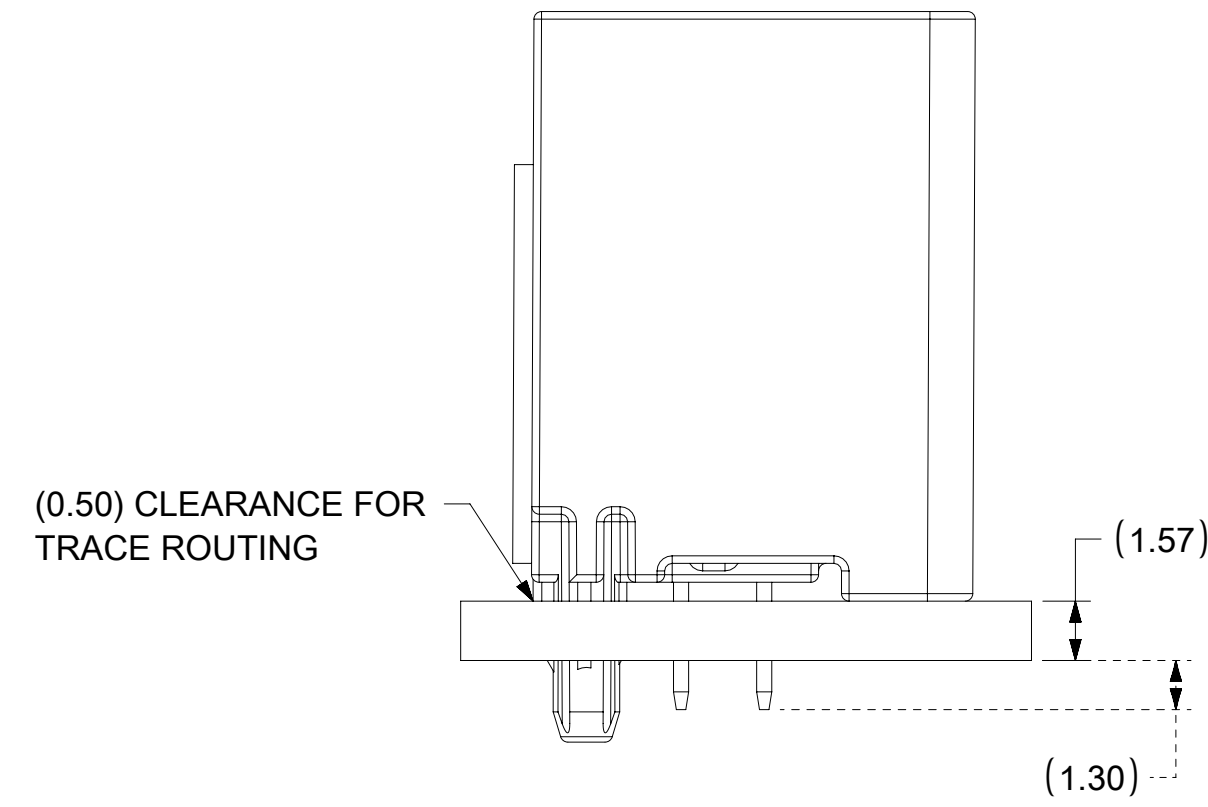
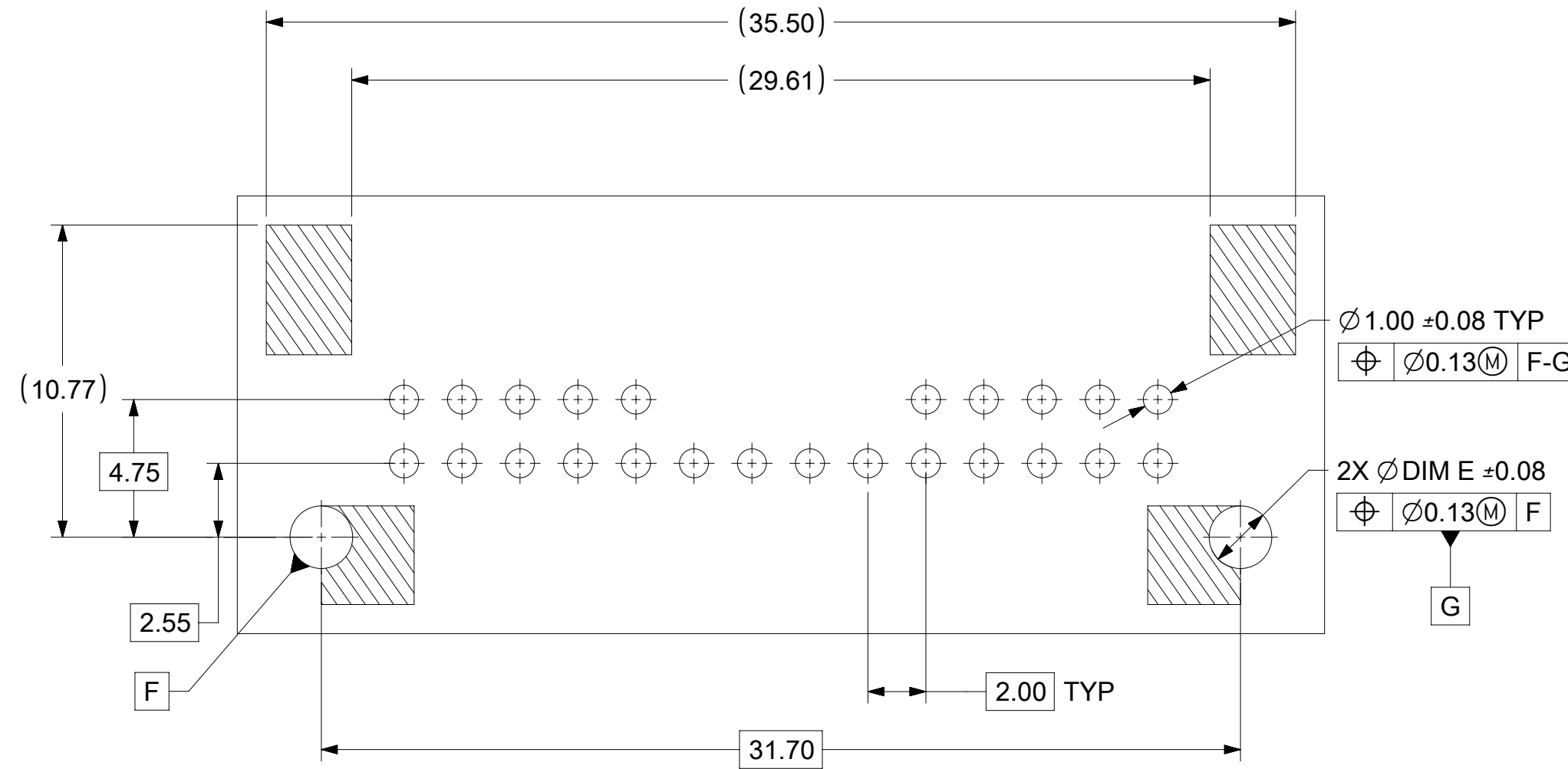

THIS DRAWING CONTAINS INFORMATION THAT IS PROPRIETARY TO MOLEX ELECTRONIC TECHNOLOGIES, LLC AND SHOULD NOT BE USED WITHOUT WRITTEN PERMISSION

DIMENSION UNITS	SCALE	CURRENT REV DESC:					
mm	5:1						
GENERAL TOLERANCES (UNLESS SPECIFIED)				MINI50 12-24CKT VERT HDR SALES DRAWING			
ANGULAR TOL	± 3.0°	EC NO: 638521		PRODUCT CUSTOMER DRAWING			
4 PLACES	±	DRWN: SRUSS 2020/05/28		DOCUMENT NUMBER			
3 PLACES	±	CHK'D: KHEWITT 2020/05/28		DOC TYPE			
2 PLACES	± 0.1	APPR: JDUNAJ 2020/05/29		DOC PART			
1 PLACE	± 0.2	INITIAL REVISION:		REVISION			
0 PLACES	±	DRWN: TMACHUGA 2012/05/03		SD-34825-001			
DRAFT WHERE APPLICABLE MUST REMAIN WITHIN DIMENSIONS		APPR: SMARCEAU 2012/05/03		PSD		001	
THIRD ANGLE PROJECTION		DRAWING		SERIES		MATERIAL NUMBER	
		D-SIZE		34825		CUSTOMER	
				GENERAL MARKET		SHEET NUMBER	
						3 OF 5	

MINI50 VERTICAL HEADER ASSEMBLIES

MATERIAL NUMBER TAPE AND REEL PACKAGING PK-47799-0001	MATERIAL NUMBER TUBE PACKAGING PK-31301-688	MATERIAL NUMBER TRAY PACKAGING PK-31301-440	CONFIGURATION	CIRCUIT	VOIDED CIRCUITS	POL	COLOR	BLADE PLATING	*MATING RECEPTACLE - PBT MATERIAL	
									UN-BRIDGED	BRIDGED
34825-8124	34825-9124	34825-0124	USCAR	12	N/A	A	BLACK	TIN OVER NICKEL	34824-0124	34824-1124
34825-8125	34825-9125	34825-0125	USCAR	12	N/A	B	GRAY	TIN OVER NICKEL	34824-0125	34824-1125
34825-8126	34825-9126	34825-0126	USCAR	12	N/A	C	DARK GRAY	TIN OVER NICKEL	34824-0126	34824-1126
34825-8160	34825-9160	34825-0160	USCAR	16	N/A	A	BLACK	TIN OVER NICKEL	34824-0160	34824-1160
34825-8161	34825-9161	34825-0161	USCAR	16	N/A	B	GRAY	TIN OVER NICKEL	34824-0161	34824-1161
34825-8162	34825-9162	34825-0162	USCAR	16	N/A	C	DARK GRAY	TIN OVER NICKEL	34824-0162	34824-1162
34825-8200	34825-9200	34825-0200	USCAR	20	N/A	A	BLACK	TIN OVER NICKEL	34824-0200	34824-1200
34825-8207	N/A	N/A	USCAR	20	1,2,4,5,7,8,10-12, 14,15,17-19	A	BLACK	TIN OVER NICKEL	34824-0200	34824-1200
34825-8201	34825-9201	34825-0201	USCAR	20	N/A	B	GRAY	TIN OVER NICKEL	34824-0201	34824-1201
34825-8202	34825-9202	34825-0202	USCAR	20	N/A	C	DARK GRAY	TIN OVER NICKEL	34824-0202	34824-1202
34825-8240	34825-9240	34825-0240	USCAR	24	N/A	A	BLACK	TIN OVER NICKEL	34824-0240	34824-1240
N/A	N/A	34825-0244	USCAR	24	2,3,4,7,8,9 12,13,14,16,19,21 ,22,23	A	BLACK	TIN OVER NICKEL	34824-0240	34824-1240
34825-8241	34825-9241	34825-0241	USCAR	24	N/A	B	GRAY	TIN OVER NICKEL	34824-0241	34824-1241
N/A	N/A	34825-0245	USCAR	24	2,3,4,7,8,9 12,13,14,16,19,21 ,22,23	B	GRAY	TIN OVER NICKEL	34824-0241	34824-1241
34825-8242	34825-9242	34825-0242	USCAR	24	N/A	C	DARK GRAY	TIN OVER NICKEL	34824-0242	34824-1242

***PLEASE NOTE RECEPTACLE MATERIAL DIFFERENCE**

THIS DRAWING CONTAINS INFORMATION THAT IS PROPRIETARY TO MOLEX ELECTRONIC TECHNOLOGIES, LLC AND SHOULD NOT BE USED WITHOUT WRITTEN PERMISSION											
DIMENSION UNITS mm		SCALE 1:1		CURRENT REV DESC:						molex	
GENERAL TOLERANCES (UNLESS SPECIFIED)				EC NO: 638521 DRWN: SRUSS 2020/05/28 CHK'D: KHEWITT 2020/05/28 APPR: JDUNAJ 2020/05/29							
ANGULAR TOL ± 3.0°		4 PLACES ±		3 PLACES ±		2 PLACES ± 0.1		INITIAL REVISION:		MINI50 12-24CKT VERT HDR SALES DRAWING	
1 PLACE ± 0.2		0 PLACES ±		DRWN: TMACHUGA 2012/05/03 APPR: SMARCEAU 2012/05/03		PRODUCT CUSTOMER DRAWING		DOCUMENT NUMBER			
DRAFT WHERE APPLICABLE MUST REMAIN WITHIN DIMENSIONS		THIRD ANGLE PROJECTION 		DRAWING D-SIZE		SERIES 34825		MATERIAL NUMBER SD-34825-001		DOC TYPE PSD	
CUSTOMER GENERAL MARKET		SHEET NUMBER 4 OF 5		DOC PART 001		REVISION H1					

MINI50 VERTICAL HEADER ASSEMBLIES

MATERIAL NUMBER TAPE AND REEL PACKAGING PK-47799-0001	MATERIAL NUMBER TUBE PACKAGING PK-31301-688	MATERIAL NUMBER TRAY PACKAGING PK-31301-440	CONFIGURATION	CIRCUIT	VOIDED CIRCUITS	POL	COLOR	BLADE PLATING	*MATING RECEPTACLE - ECOPAXX MATERIAL	
									UN-BRIDGED	BRIDGED
34825-8160	34825-9160	34825-0160	USCAR	16	N/A	A	BLACK	TIN OVER NICKEL	34824-0164	34824-1164
34825-8161	34825-9161	34825-0161	USCAR	16	N/A	B	GRAY	TIN OVER NICKEL	34824-0165	34824-1165
34825-8162	34825-9162	34825-0162	USCAR	16	N/A	C	DARK GRAY	TIN OVER NICKEL	34824-0166	34824-1166
34825-8200	34825-9200	34825-0200	USCAR	20	N/A	A	BLACK	TIN OVER NICKEL	34824-0204	34824-1204
34825-8207	N/A	N/A	USCAR	20	1,2,4,5,7,8,10-12, 14,15,17-19	A	BLACK	TIN OVER NICKEL	34824-0204	34824-1204
34825-8201	34825-9201	34825-0201	USCAR	20	N/A	B	GRAY	TIN OVER NICKEL	34824-0205	34824-1205
34825-8202	34825-9202	34825-0202	USCAR	20	N/A	C	DARK GRAY	TIN OVER NICKEL	34824-0206	34824-1206
34825-8240	34825-9240	34825-0240	USCAR	24	N/A	A	BLACK	TIN OVER NICKEL	34824-0244	34824-1244
N/A	N/A	34825-0244	USCAR	24	2,3,4,7,8,9 12,13,14,16,19,21 ,22,23	A	BLACK	TIN OVER NICKEL	34824-0244	34824-1244
34825-8241	34825-9241	34825-0241	USCAR	24	N/A	B	GRAY	TIN OVER NICKEL	34824-0245	34824-1245
N/A	N/A	34825-0245	USCAR	24	2,3,4,7,8,9 12,13,14,16,19,21 ,22,23	B	GRAY	TIN OVER NICKEL	34824-0245	34824-1245
34825-8242	34825-9242	34825-0242	USCAR	24	N/A	C	DARK GRAY	TIN OVER NICKEL	34824-0246	34824-1246

***PLEASE NOTE RECEPTACLE MATERIAL DIFFERENCE**

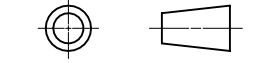
THIS DRAWING CONTAINS INFORMATION THAT IS PROPRIETARY TO MOLEX ELECTRONIC TECHNOLOGIES, LLC AND SHOULD NOT BE USED WITHOUT WRITTEN PERMISSION									
DIMENSION UNITS	SCALE	CURRENT REV DESC:							
mm	1:1	 MINI50 12-24CKT VERT HDR SALES DRAWING PRODUCT CUSTOMER DRAWING							
GENERAL TOLERANCES (UNLESS SPECIFIED)									
ANGULAR TOL	± 3.0°								
4 PLACES	±								
3 PLACES	±								
2 PLACES	± 0.1								
1 PLACE	± 0.2	EC NO: 638521	2020/05/28						
0 PLACES	±	DRWN: SRUSS	2020/05/28						
DRAFT WHERE APPLICABLE MUST REMAIN WITHIN DIMENSIONS		THIRD ANGLE PROJECTION	DRAWING	SERIES	MATERIAL NUMBER	CUSTOMER	SHEET NUMBER		
			D-SIZE	34825	SD-34825-001	GENERAL MARKET	5 OF 5		