

SYMBOL DEFINITION		MISSING NUMBERS
A DIMENSION WITHOUT AN INSPECTION REPORT SYMBOL  DOES NOT REQUIRE INSPECTION. IT MAY BE CONTROLLED ON AN INDIVIDUAL COMPONENT DRAWING.	TOTAL NO. OF SYMBOLS ON DRAWING	8
	LAST NO. USED	8

DWG STATUS					REVISION HISTORY				AUTH	DR	APVD1	APVD2
DATE	STG	REV	N/P	CHG								
170C00	R	21	-	-	ALL ACTIVE PARTS - ADDED REVISION COLUMN PER 148574				204031	RVP	RVP	RC
03AU04	R	22	-	-	02977253 - MAT'L SPEC WAS R-67550; 02973778 - MAT'L SPEC WAS PM-661-001; & 06288219 - MAT'L SPEC WAS R-71753; ALL ACTIVE PARTS - REVISED NOTES				257213	TLD	TLD	ET
27SE05	R	23	-	-	06288219 - MAT'L SPEC WAS M3592002				272768	CCV	FRG	ET
12MR07	R	24	-	-	06288219 - OBSOLETE				400766	JBD	JAA	JBS

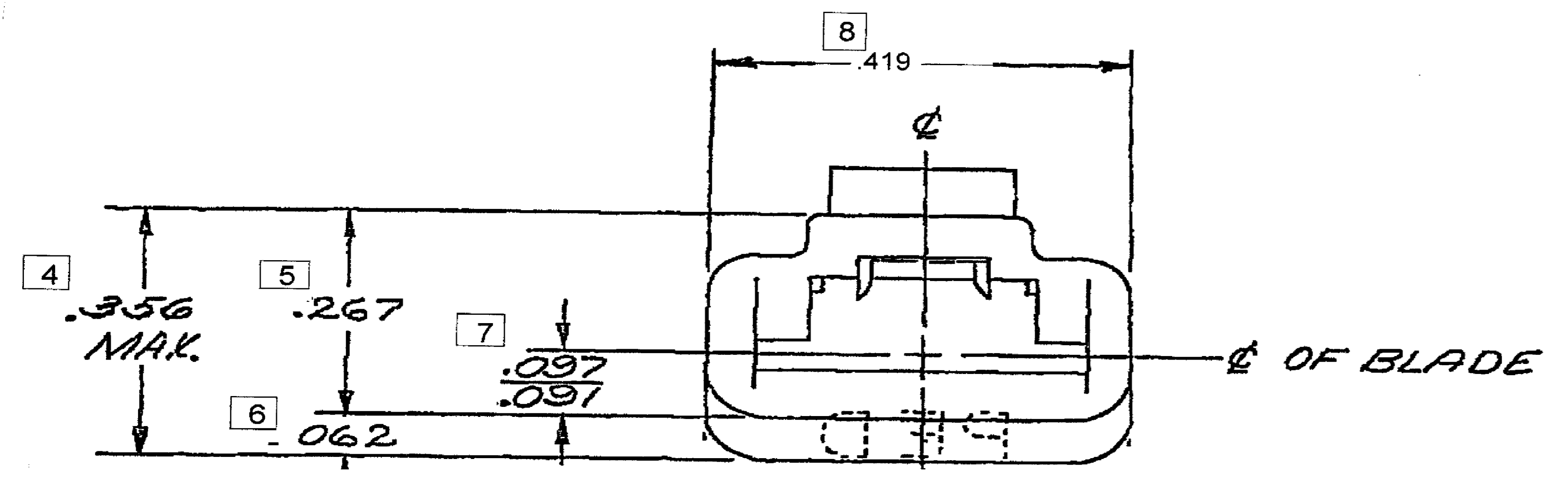
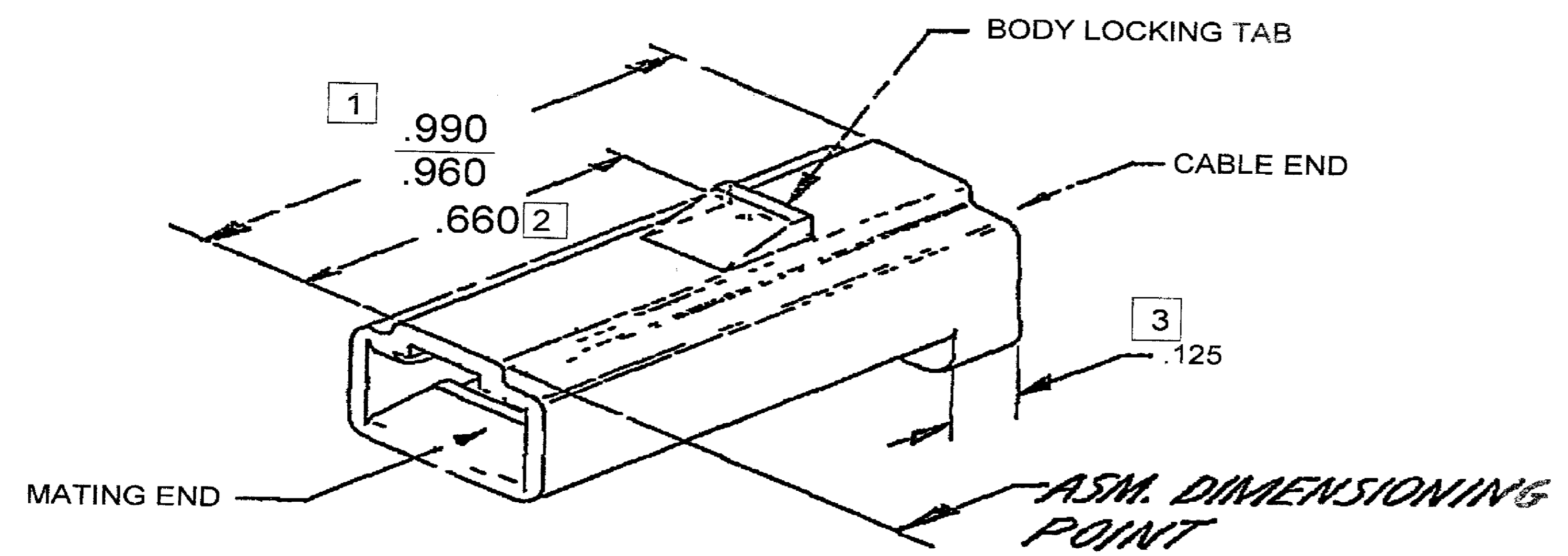

- NOTES
- UNLESS OTHERWISE SPECIFIED AND/OR INDICATED:
DIMENSIONS ARE TO FACE OF VIEW SHOWN AND AUTOMATICALLY ROUNDED BY COMPUTER FOR INSPECTION (SEE MATH MODEL FOR PRECISE DIMENSIONS). FOR ALL OTHER DIMENSIONS NOT SHOWN BUT REQUIRED FOR TOOL BUILD, SEE MATH MODEL FOR PRECISE TOOL PATH DATA.
 - MATERIAL RECYCLING CODE PER ISO 11469. (.080)X(.004) RAISED CHARACTERS AS SHOWN TO BE LOCATED ON ANY EXTERIOR SURFACE. OPTIONAL CONSTRUCTION TO BE NO MATERIAL RECYCLING CODE.
 - REFERENCE MATING COMPONENTS OR EQUIVALENT:
CONNECTOR 02973779
 - (.080)X(.004) RAISED DELPHI CORPORATE BRAND TO BE LOCATED ON ANY EXTERIOR SURFACE, PREFERABLY VISIBLE AT FINAL ASSEMBLY. OPTIONAL CONSTRUCTION TO BE "PED" OR NO LOGO.
 - ENVIRONMENTAL PROTECTION ACCORDING TO OPEL SPECIFICATION QU 000 001-CADMIUM

PART NO	REV	N/P	STATUS	MATERIAL SPECIFICATION AND COLOR	REMARKS
06288219	08	AA	OBSOLETE	M3592024 PA66 HS IM CRM	-
02989922	G	-	OBSOLETE	R-67662 - A.B.S. (NAT)	MUST BE MADE IN MOLD #M-1
02977253	08	-	-	M2097001 PP IM BLK	SEE NOTE #5
02973778	08	-	-	M2097002 PP IM NAT	-

(N/A) PROCESS SENSITIVE DIMENSION	
DIMENSIONS ENCLOSED IN () INDICATE REFERENCE DIMENSIONS AND NO TOLERANCE LIMITS ARE ESTABLISHED	
DIMENSIONAL RANGE (IN)	CHART H
FROM 0	>.750
TO .750	>1.250
	>2.750
	>4.000
	>4.000
TOLERANCE UNLESS OTHERWISE SPECIFIED	
	±.005
	±.010
	±.012
	±.016
	±.020
ANGULAR TOLERANCE ±2°	

DWG TYPE PART DRAWING	
STYLE	
VOLUME (C/P)	DISTR CODE
UNLESS OTHERWISE SPECIFIED	
THIS DOCUMENT IS IN ACCORDANCE WITH ASME Y14.5M-1994 AS AMENDED BY THE 2001 GLOBAL DIMENSIONING AND TOLERANCING ADDENDUM-2001. SEPARATE PATTERNS OF FEATURES MAY BE GAGED SEPARATELY REGARDLESS OF DATUM REFERENCES.	
ALL DIMENSIONS ARE IN INCHES	
THIRD ANGLE PROJECTION	DO NOT SCALE
USE MATH DATA	UNIGRAPHICS

DELPHI	
DELPHI PACKARD ELECTRICAL/ELECTRONIC ARCHITECTURE WARREN, OH	
DR	DATE
APVD1 TOM MUDREY	21N060
APVD2 DON THIRY	04AU66
APVD3 LUBERT	10AU66
APVD4	
APVD5	
SUBSTANCES OF CONCERN AND RECYCLED CONTENT PER DELPHI 10945001	
MATERIAL SEE CHART	
DRAWING NAME TAXI CONN F 56 SERIES	
DRAWING NUMBER 02977252	
SIZE A1	SCALE NONE
FRAME NO 1 OF 1	SHEET NO 1 OF 1
STG R	REV 24
N/P -	