

3-520107-2 ✓ ACTIVE

Ultra-Fast | Ultra-Fast 250

TE Internal #: 3-520107-2

Quick Disconnects, Tab, 16 – 14 AWG Wire Size, 1.31 – 2.08 mm²

Wire Size, Mating Tab Width .25 in [6.35 mm], Straight, Brass, Ultra-Fast 250

[View on TE.com >](#)



Terminals & Splices > Quick Disconnects

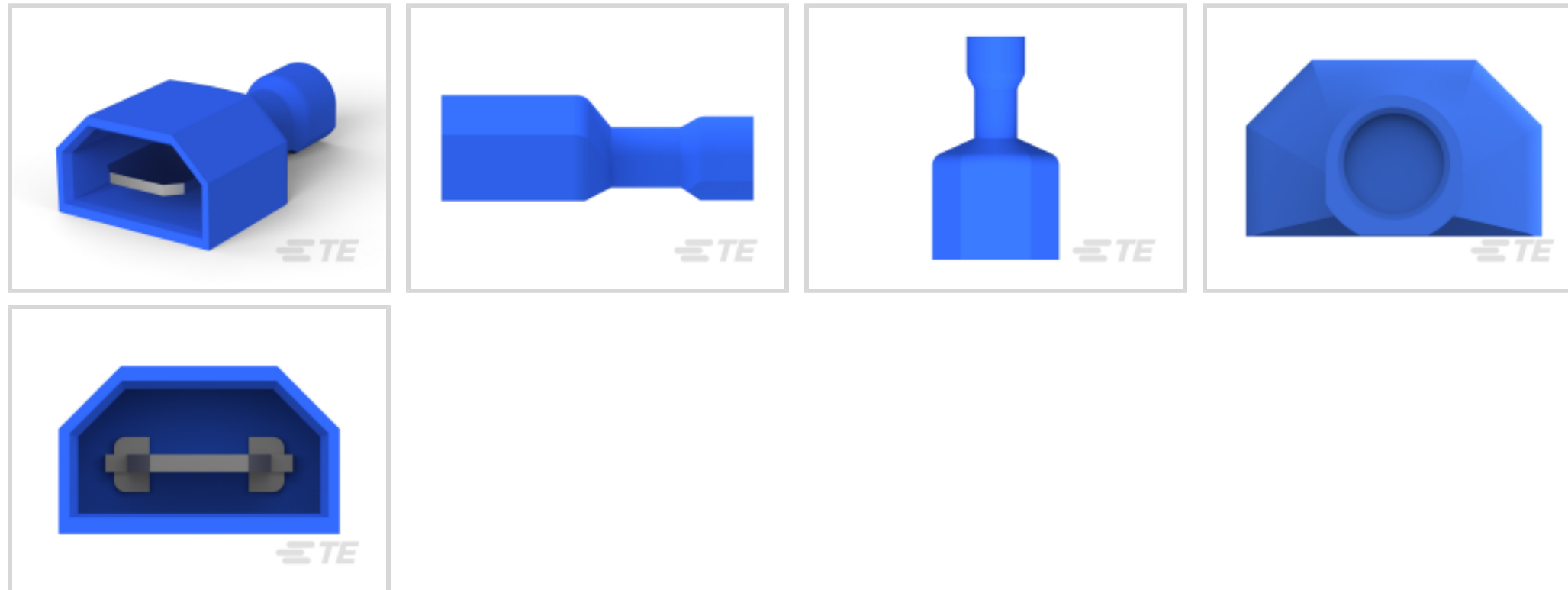

Quick Disconnect Terminal Type: **Tab**

Wire Size: **1.31 – 2.08 mm²**

Mating Tab Width: **6.35 mm [.25 in]**

Mating Tab Thickness: **.81 mm [.032 in]**

Features

Product Type Features

Terminates To	Wire & Cable
Wire/Cable Type	Regular Wire
Wire Stop	No
Insertion Force	Normal
Sealable	No

Configuration Features

Connection Capacity	Single
---------------------	--------

Electrical Characteristics

Voltage (Max)	600 V
---------------	-------

Body Features

Insulation Material	Nylon
---------------------	-------

Contact Features

Quick Disconnect Terminal Type	Tab
Mating Tab Width	6.35 mm [.25 in]



Mating Tab Thickness	.81 mm[.032 in]
Terminal Orientation	Straight
Contact Base Material	Brass
Terminal Plating Material	Tin
Crimp Type	F-Crimp
Barrel Type	Closed

Mechanical Attachment

Mating Retention Type	Dimple
Wire Insulation Support	With

Dimensions

Accepts Wire Insulation Diameter Range	4.06 mm[.16 in]
Receptacle Terminal Stock Thickness	.41 mm[.016 in]
Overall Length	21.75 mm[.855 in]
Wire Size	1.31 – 2.08 mm ²

Usage Conditions

Insulation Option	Uninsulated
Operating Temperature Range	-40 – 110 °C[-40 – 230 °F]

Industry Standards

UL Flammability Rating	UL 94V-2
UL Rating	Listed

Packaging Features

Packaging Quantity	1000
Packaging Method	Loose Piece/Carton

Other

Barrel Color	Blue
--------------	------

Product Compliance

[For compliance documentation, visit the product page on TE.com>](#)

EU RoHS Directive 2011/65/EU	Compliant
EU ELV Directive 2000/53/EC	Compliant
China RoHS 2 Directive MIIT Order No 32, 2016	No Restricted Materials Above Threshold
EU REACH Regulation (EC) No. 1907/2006	



Current ECHA Candidate List: JUNE 2022
 (224)
 Candidate List Declared Against: JAN 2022
 (223)
 SVHC > Threshold:
 Not Yet Reviewed

Halogen Content
 Low Halogen - Br, Cl, F, I < 900 ppm per homogenous material. Also BFR/CFR/PVC Free

Solder Process Capability
 Not applicable for solder process capability

Product Compliance Disclaimer

This information is provided based on reasonable inquiry of our suppliers and represents our current actual knowledge based on the information they provided. This information is subject to change. The part numbers that TE has identified as EU RoHS compliant have a maximum concentration of 0.1% by weight in homogenous materials for lead, hexavalent chromium, mercury, PBB, PBDE, DBP, BBP, DEHP, DIBP, and 0.01% for cadmium, or qualify for an exemption to these limits as defined in the Annexes of Directive 2011/65/EU (RoHS2). Finished electrical and electronic equipment products will be CE marked as required by Directive 2011/65/EU. Components may not be CE marked. Additionally, the part numbers that TE has identified as EU ELV compliant have a maximum concentration of 0.1% by weight in homogenous materials for lead, hexavalent chromium, and mercury, and 0.01% for cadmium, or qualify for an exemption to these limits as defined in the Annexes of Directive 2000/53/EC (ELV). Regarding the REACH Regulation, the information TE provides on SVHC in articles for this part number is based on the latest European Chemicals Agency (ECHA) 'Guidance on requirements for substances in articles' posted at this URL: <https://echa.europa.eu/guidance-documents/guidance-on-reach>

Compatible Parts

TE Part # 58628-2
 PROCIMP DIESET 26-14 ULTRAFast

TE Part # 58628-1
 PROCIMP T&D 26-14 ULTRAFast

TE Part # 90391-3
 DIES ULTRA-FAST FASTON 16-14 DIE SET

TE Part # 2217481-1
 KIT, BTLI, SDE CLOSED HEAD

TE Part # 2217481-2
 KIT, BTLI, SDE CLOSED HEAD

Also in the Series | [Ultra-Fast 250](#)



Quick Disconnects(49)

Customers Also Bought

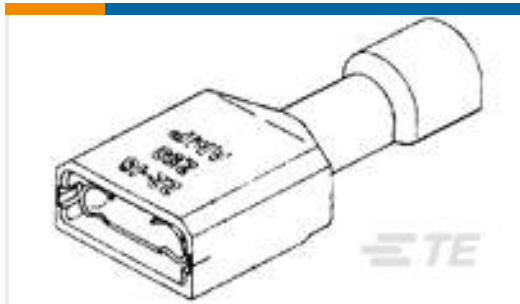

TE Part #4-520448-2
ULTRAFAST 250 ASSY REC 12-10
TPBR LP

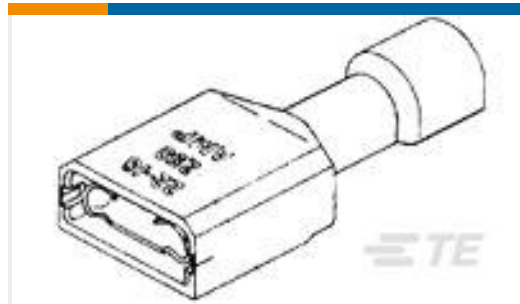

TE Part #3-520408-2
ULTRA-FAST 250 ASY REC 16-14 AWG
TPBR

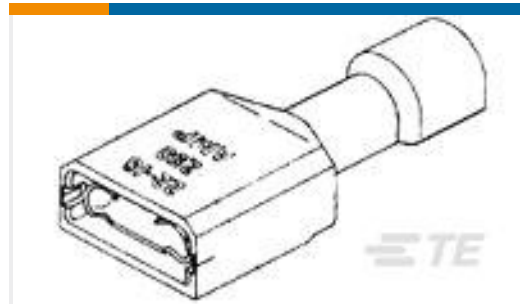

TE Part #3-520141-2
ULTRAFAST 250 ASSY REC 16-14
TPBR LP

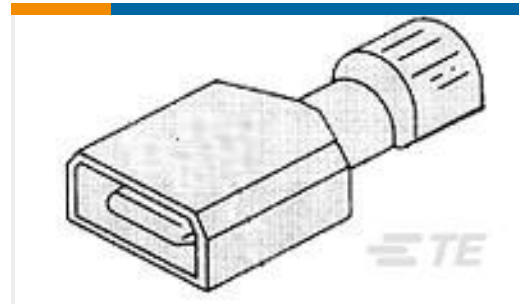

TE Part #4-521098-2
ULTRA-FAST 250 ASSEMBLY 12-10
AWG TPBR

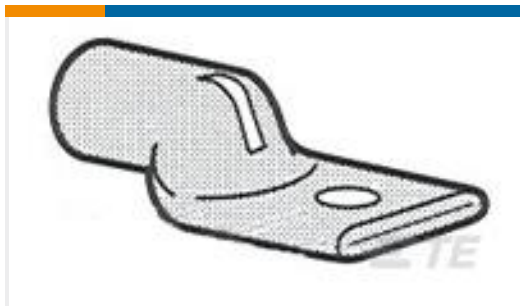

TE Part #328178
TERMINAL,AMPOWER 4 1/2



TE Part #5-1415535-8
RT4S4LB2



TE Part #1393130-9
PRD-7AY0-24=PRD

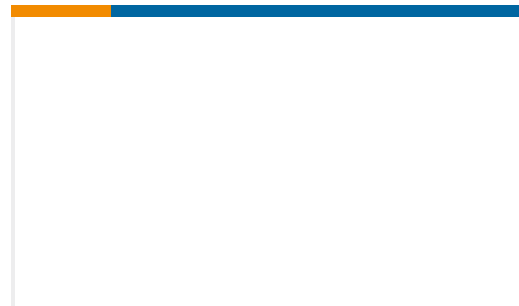

TE Part #C07752-000
TFT-252E-SG-BRKT-1-SS

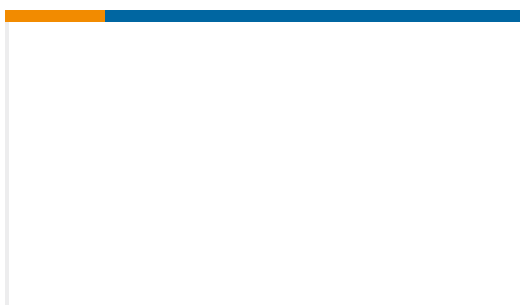

TE Part #969029-5
TAB A 1.6x0.6 CONTACT CS SWS Ag
(LP)

Documents

Product Drawings

[ULTRA-FAST 250 ASY TAB 16-14 AWG TPBR](#)

English

CAD Files

[3D PDF](#)

[3D](#)

Customer View Model

[ENG_CVM_CVM_3-520107-2_C.2d_dxf.zip](#)



English

Customer View Model

[ENG_CVM_CVM_3-520107-2_C.3d_igs.zip](#)

English

Customer View Model

[ENG_CVM_CVM_3-520107-2_C.3d_stp.zip](#)

English

By downloading the CAD file I accept and agree to the [Terms and Conditions](#) of use.

Datasheets & Catalog Pages

[Ultra-Fast and Ultra Fast Plus](#)

English

Product Specifications

[Application Specification](#)

English

Product Environmental Compliance

[MD_3-520107-2_10082014012_dmtec](#)

English

[MD_3-520107-2_10082014012_dmtec](#)

English

Agency Approvals

[UL](#)

English