

REVISIONS					
P	LTR	DESCRIPTION	DATE	DWN	APVD
	B1	Redrawn to Creo	10MAR2017	JJH	JP

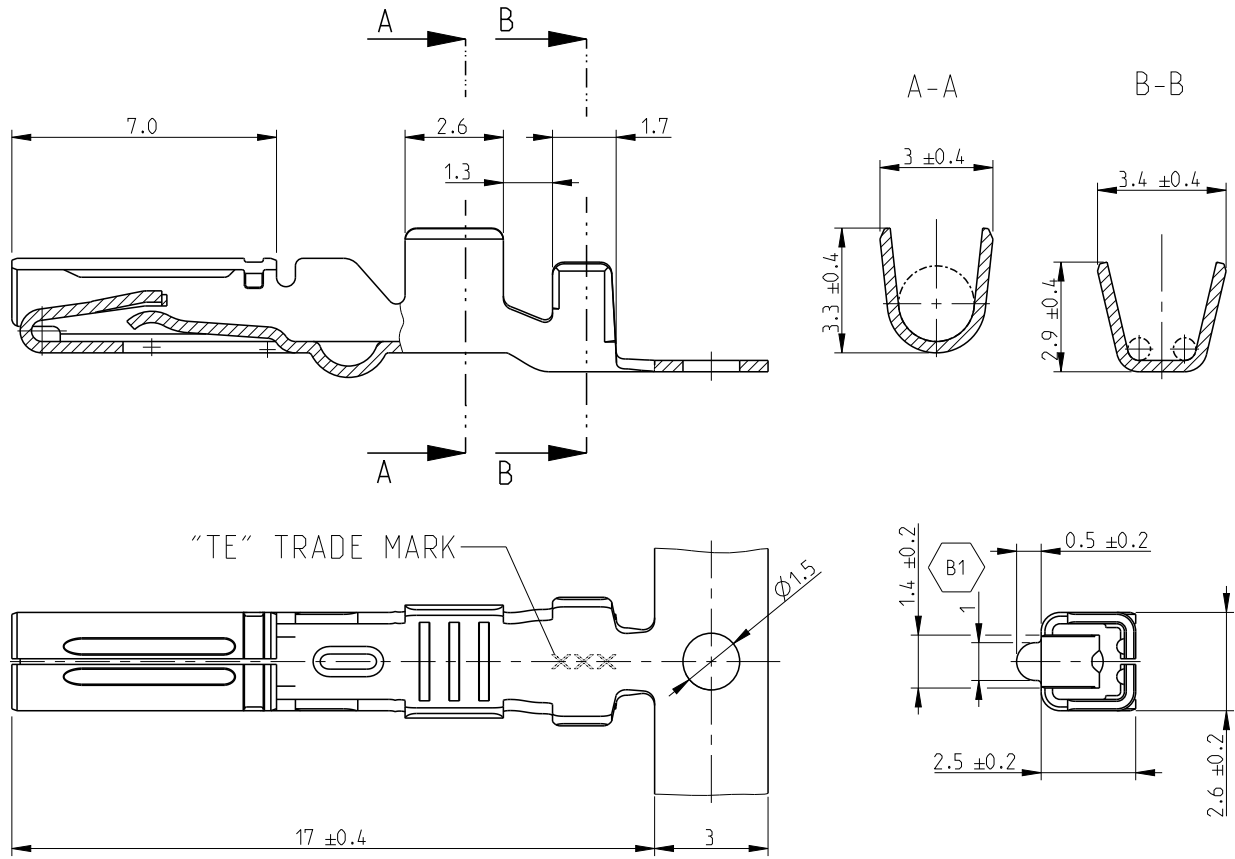

1. DELIVERY STATE: ITEM IS SUPPLIED REELED ON CARTON REEL WITH STRIP PITCH = 11.9±0.2mm  
 STATO DI FORNITURA: AVVOLTI SU BOBINA CON PASSO TRA TERMINALI DI = 11.9±0.2mm

CUSTOMER DRAWING FOR INFORMATION ONLY  
 DISEGNO PER CLIENTE SOLO PER RIFERIMENTO

THIS DRAWING IS UNPUBLISHED. BY - ALL RIGHTS RESERVED. COPYRIGHT 20

	INS. DIA. RANGE (DIAM. ISOLANTE)	WIRE RANGE (RANGO FILO)	PRE-TIN (PRE-STAGNATO)	BRASS (OTTONE)	282431-1										
	Ø2.1 - 2.4mm	0.75 - 1.5mm <sup>2</sup>	FINISH/COLOUR (FINITURE/COLORE)	MATERIAL (MATERIALE)	PART NUMBER										
DIMENSIONS: mm	DWN M. CASAGRANDE 09NOV1992	MATERIAL	FINISH												
TOLERANCES UNLESS OTHERWISE SPECIFIED:	CHK G. VIGNOLI 21APR1993	TE Connectivity													
<table border="1"> <tr> <td>PLC</td> <td>±</td> </tr> <tr> <td>1 PLC</td> <td>±</td> </tr> <tr> <td>2 PLC</td> <td>±</td> </tr> <tr> <td>3 PLC</td> <td>±</td> </tr> <tr> <td>4 PLC</td> <td>±</td> </tr> </table> ±0.3	PLC					±	1 PLC	±	2 PLC	±	3 PLC	±	4 PLC	±	APVD -
PLC	±														
1 PLC	±														
2 PLC	±														
3 PLC	±														
4 PLC	±														
<table border="1"> <tr> <td>ANGLES</td> <td>±2°</td> </tr> </table>	ANGLES	±2°	PRODUCT SPEC 108-20158	SIZE	CAGE CODE	DRAWING NO	RESTRICTED TO								
ANGLES	±2°														
	APPLICATION SPEC 114-20061	A 4	-	©=282431	-										
	WEIGHT -	CUSTOMER DRAWING		SCALE 5:1	SHEET 1 OF 1										
					REV B1										