

THIS DRAWING IS UNPUBLISHED.

RELEASED FOR PUBLICATION

© COPYRIGHT

ALL RIGHTS RESERVED.

REVISIONS

P	LTR	DESCRIPTION	DATE	DWN	APVD
	C	REVISED(ECR-16-005736)	07.APR.16	WY	KT
	C2	REVISED(ECR-16-007243)	25.JAN.16	WY	KT

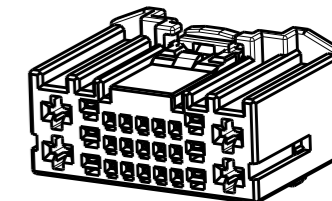
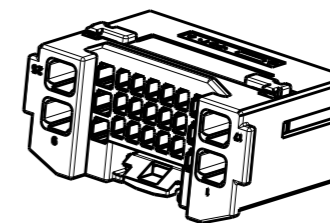
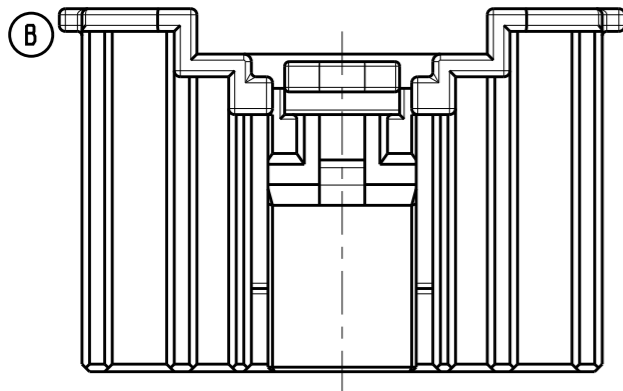

C2 TENTATIVE RELEASED

UNDER VALIDATION (DUE TO 31.AUG.2018)

TABLE 1.

CONTACT	PART NO.	WIRE SIZE(SQ)
.025 TH	2005097-1	0.13-0.22
	2005427-1	0.3-0.5
	1123343-2	0.5
.060	2109006-1	0.22-0.35
	2109006-2	0.5-0.75
	2109006-3	0.85-1.25
	8-2109006-2	AL0.75
	8-2109006-3	AL1.25
MCP 2.8	1-968880-1	0.35-0.5
	1-968849-1	0.5-1.0
	1-968851-1	1.0-2.5

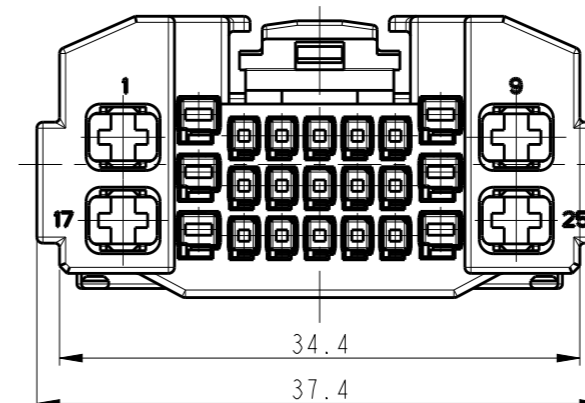
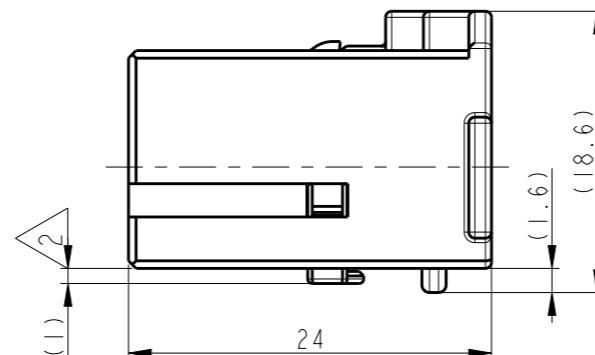
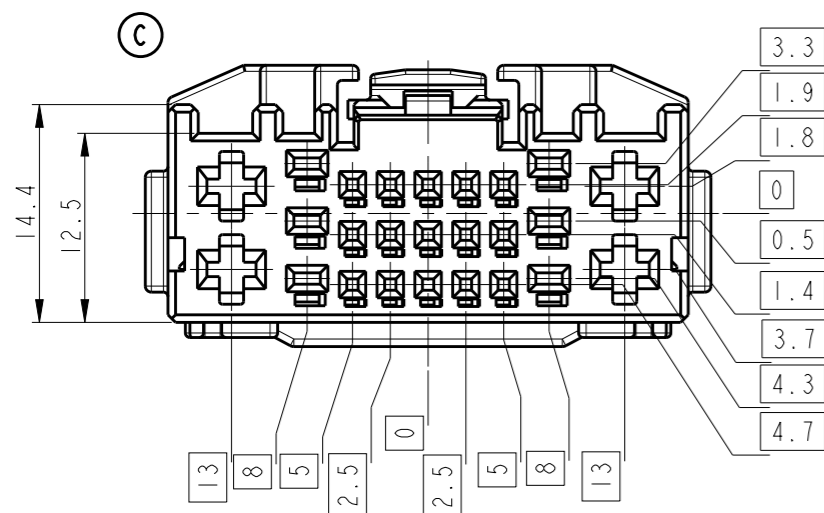

NOTE

- 1. GENERAL TOLERANCE : $\pm 0.3, \pm 3^\circ$
- 2. CONDITION OF DELIVERY : DBL PLATE IN OPEN POSITION.
- 3. APPLIED RECEPTACLE CONTACT P/N:SEE TABLE 1
- 4. SUITABLE MATING CAP P/N : 2109517
- 5. MATING INTERFACE PART NUMBER: 114-61056

B1

ASS'Y P/N	2109520-3	2109520-1

NO	FINISH/COLOR	MATERIAL	DESCRIPTION	Q'TY
2	NATURAL	PBT	25P DBL HSG	1
1	C2 GRAY	PBT	25P PLUG HSG	1
	NATURAL			-

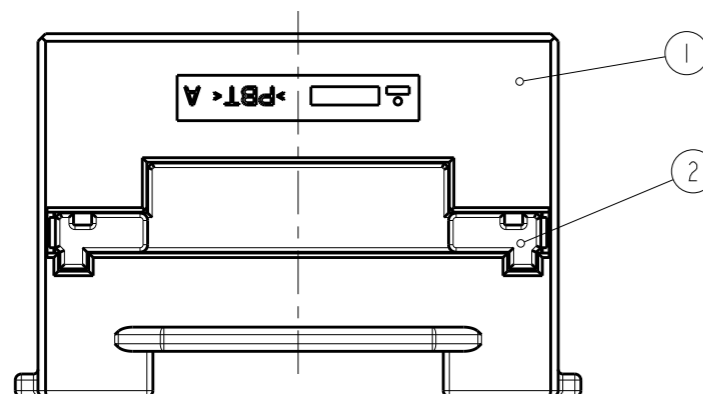

THIS DRAWING IS A CONTROLLED DOCUMENT.		DWN WY JANG		 TE Connectivity	
DIMENSIONS:		CHK YH MA			
TOLERANCES UNLESS OTHERWISE SPECIFIED:		APVD KT LIM		NAME	
\pm PLC \pm 1 PLC \pm 2 PLC \pm 3 PLC \pm 4 PLC \pm ANGLES \pm FINISH		PRODUCT SPEC		025/060/110 HYB 25P PLUG ASSY	
MATERIAL SEE NOTE		APPLICATION SPEC		RESTRICTED TO	
		WEIGHT		SIZE CAGE CODE DRAWING NO	
		CUSTOMER DRAWING		A3 00779 C-2109520	
		SCALE 2:1		SHEET 1 OF 1 REV C2	