

NOTES:

- MATERIAL:
HOUSING & REAR SEAL CAP: NYLON, UL94V-0, COLOR: BLACK
SEALS: INHERENTLY LUBRICATED SILICONE
- FINISH: NONE
- PRODUCT SPECIFICATION: 2042200000-PS
- APPLICATION SPECIFICATION: 2042200000-AS
- PACKAGING SPECIFICATION: 2042200000-PK
- PART MATES WITH PLUG SERIES 204223.
- PART USES TERMINAL PART NUMBER 2043010001.
- PART CONFORMS TO COSMETIC SPEC: PS-45499-002 CLASS C
- VOIDED CIRCUITS HAVE A PLUG IN THE MATTE SEAL TO SEAL THE CIRCUIT AND WILL NOT ACCEPT TERMINALS.

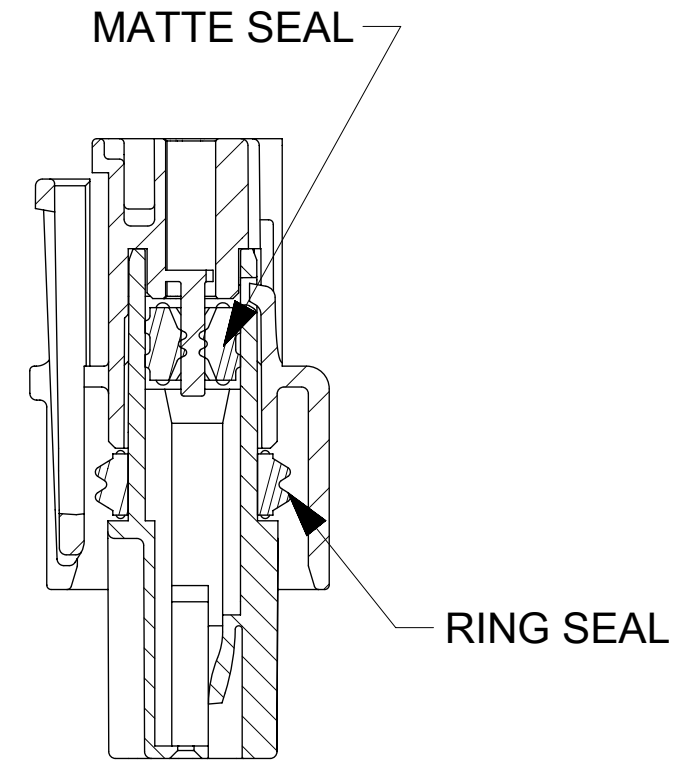

SECTION A-A
TERMINAL SHOWN INSERTED
INTO HOUSING

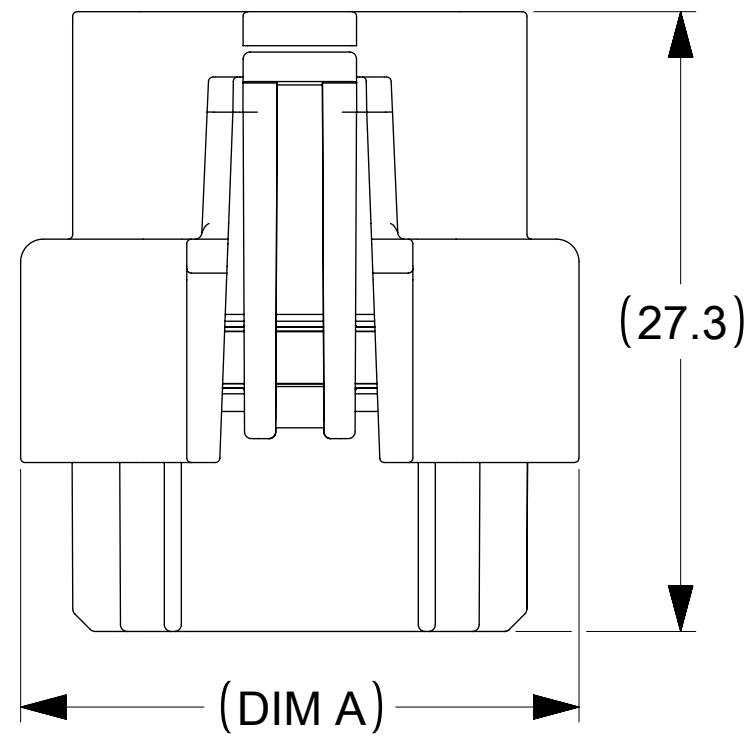
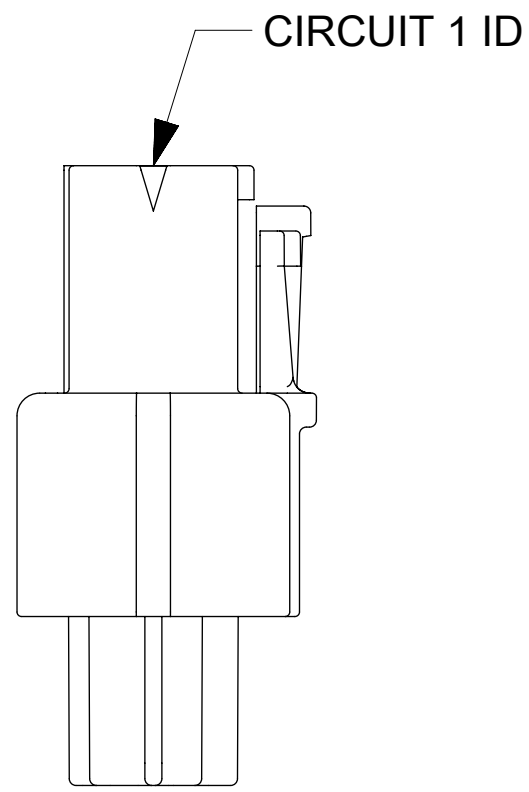
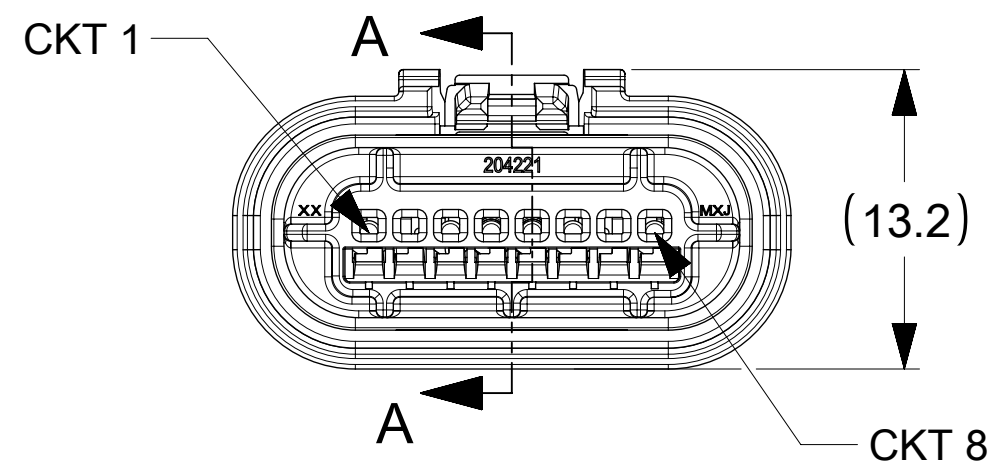

LASER MARK THIS SURFACE
MOLEX PART NUMBER AND
JULIAN DATE CODE: DDDYY

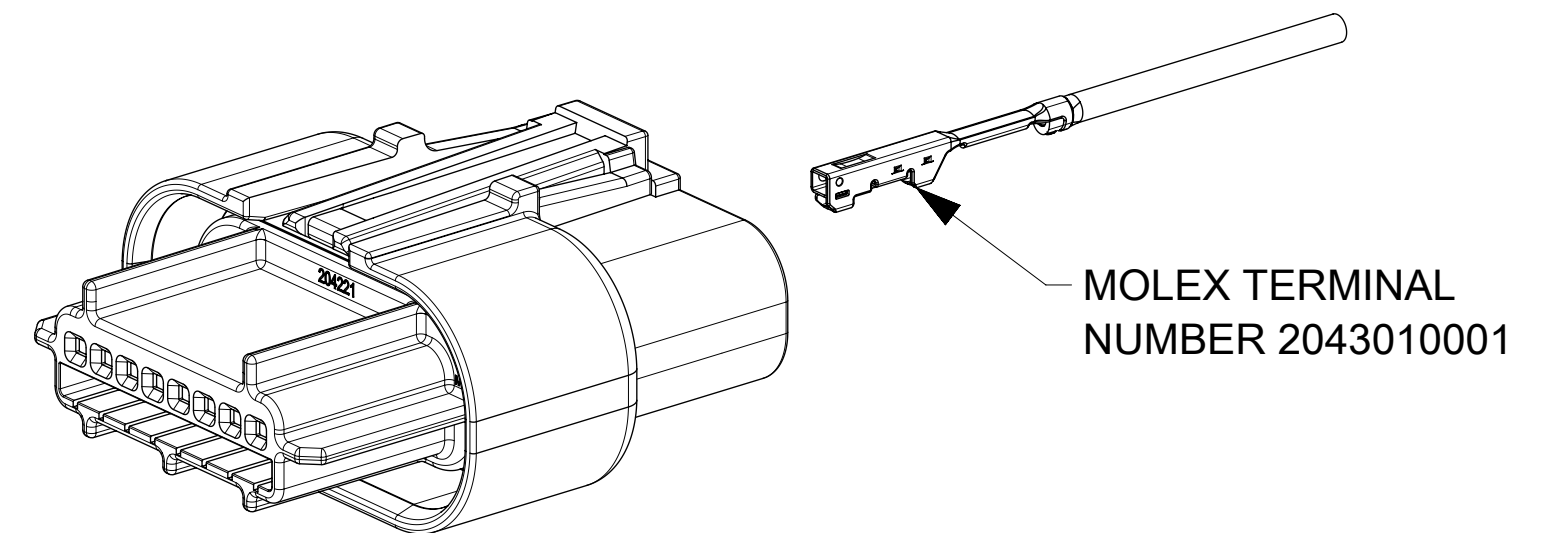
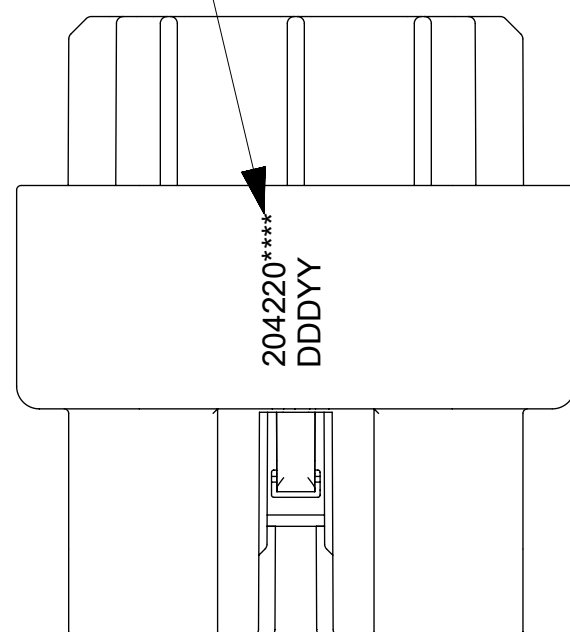

CIRCUIT SIZE	DIM A
2	13.8
4	17.4
6	21.0
8	24.6
10	28.2

THIS DRAWING CONTAINS INFORMATION THAT IS PROPRIETARY TO MOLEX ELECTRONIC TECHNOLOGIES, LLC AND SHOULD NOT BE USED WITHOUT WRITTEN PERMISSION											
SYMBOLS		DIMENSION UNITS		SCALE		CURRENT REV DESC: ADD ALL CKTS VOIDED PN'S					
= 0		mm		3:1							
= 0		GENERAL TOLERANCES (UNLESS SPECIFIED)									
= 0		ANGULAR TOL ± °				EC NO: 631906					
= 0		4 PLACES ±				DRWN: MKIPPER 2020/01/22					
= 0		3 PLACES ±				CHK'D: DSTEIER 2020/02/14					
= 0		2 PLACES ± 0.2				APPR: FSMITH 2020/02/19					
= 0		1 PLACE ±				INITIAL REVISION:					
= 0		0 PLACES ±				DRWN: TGREGORI 2017/04/26					
= 0		DRAFT WHERE APPLICABLE MUST REMAIN WITHIN DIMENSIONS				THIRD ANGLE PROJECTION		DRAWING		SERIES	
= 0				C-SIZE		204220		MATERIAL NUMBER		CUSTOMER	
								SEE CHART		GENERAL MARKET	
								DOCUMENT NUMBER		DOC TYPE DOC PART REVISION	
								2042200000-SD		PSD 000 A6	
								SHEET NUMBER		1 OF 2	

CIRCUIT SIZE	MATERIAL NUMBER	VOIDED CIRCUIT SEE NOTE 9
2	204220-0002	NONE
4	204220-0004	NONE
6	204220-0006	NONE
8	204220-0008	NONE
10	204220-0010	NONE
2	204220-9902	ALL CIRCUITS VOIDED
4	204220-9904	ALL CIRCUITS VOIDED
6	204220-9906	ALL CIRCUITS VOIDED
8	204220-9908	ALL CIRCUITS VOIDED
10	204220-9910	ALL CIRCUITS VOIDED
4	204220-4004	4
6	204220-6006	6
8	204220-8008	8
10	204220-1110	10

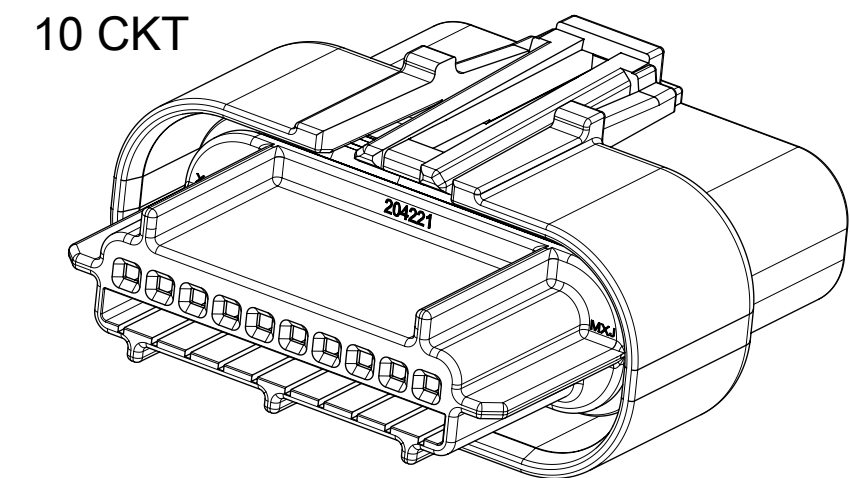
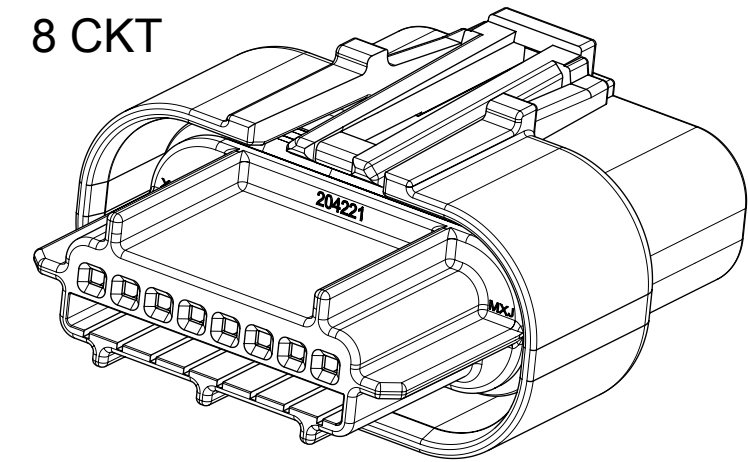
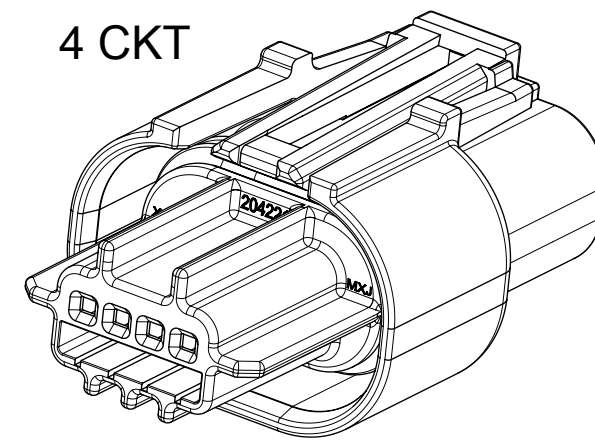
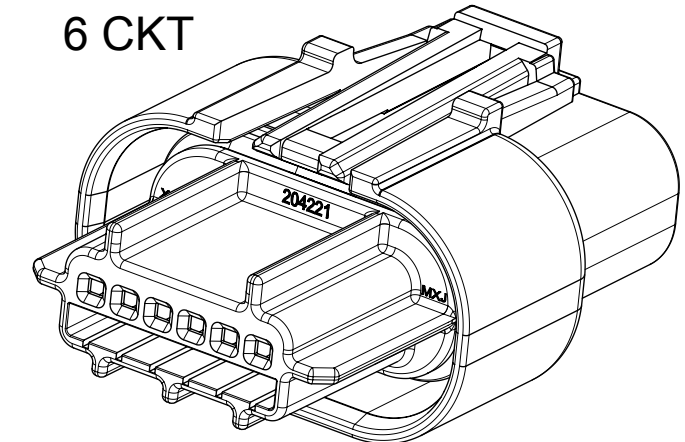
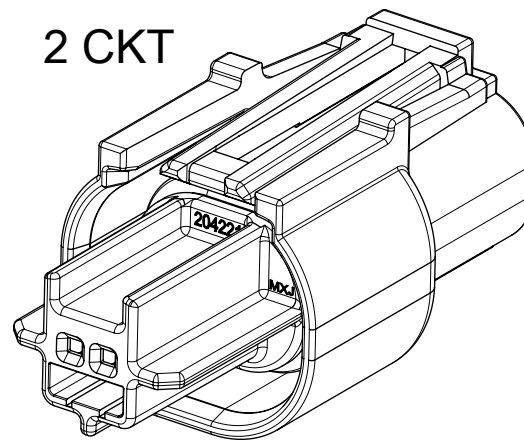

AVAILABLE CIRCUIT SIZES

SYMBOLS = 0 = 0 = 0 = 0 = 0 = 0 = 0 = 0 = 0 = 0	THIS DRAWING CONTAINS INFORMATION THAT IS PROPRIETARY TO MOLEX ELECTRONIC TECHNOLOGIES, LLC AND SHOULD NOT BE USED WITHOUT WRITTEN PERMISSION	DIMENSION UNITS: mm SCALE: 3:1		CURRENT REV DESC: ADD ALL CKTS VOIDED PN'S					
	GENERAL TOLERANCES (UNLESS SPECIFIED) ANGULAR TOL ± °		EC NO: 631906 DRWN: MKIPPER 2020/01/22 CHK'D: DSTEIER 2020/02/14 APPR: FSMITH 2020/02/19		RECEPTACLE ASSEMBLY SQUBA 1.8				
	DRAFT WHERE APPLICABLE MUST REMAIN WITHIN DIMENSIONS		THIRD ANGLE PROJECTION		DRAWING: C-SIZE SERIES: 204220		PRODUCT CUSTOMER DRAWING		
					INITIAL REVISION: DRWN: TGREGORI 2017/04/26 APPR: RHODGE 2018/01/26		DOCUMENT NUMBER: 2042200000-SD	DOC TYPE: PSD	DOC PART: 000
DOCUMENT STATUS: P1 RELEASE DATE: 2020/02/19 15:53:52						MATERIAL NUMBER: SEE CHART	CUSTOMER: GENERAL MARKET		SHEET NUMBER: 2 OF 2