

180905 ✓ ACTIVE

FASTIN-FASTON | FASTIN-FASTON 250

TE Internal #: 180905

Crimp Terminal Housings, Receptacle, Receptacle, 1 Position,
Straight, Natural, Polyamide, Mating Alignment, FASTIN-FASTON
250

[View on TE.com >](#)



Terminals & Splices > Terminal Housings, Insulation Sleeves & Blocks > Crimp Terminal Housings



Terminal Type: **Receptacle**

Housing Type: **Receptacle**

Number of Positions: **1**

Terminal Orientation: **Straight**

Primary Product Color: **Natural**

Features

Product Type Features

Terminates To	Wire & Cable
Product Type	Terminal Housing
Sealable	No
Housing Type	Receptacle
Insulated	No

Configuration Features

Number of Positions	1
---------------------	---

Body Features

Primary Product Color	Natural
-----------------------	---------

Contact Features

Terminal Type	Receptacle
Terminal Orientation	Straight
Contact Mating Retention	Without



Mechanical Attachment

Mating Alignment	With
Crimp Terminal Housing Mounting Style	Cable Mount (Free-Hanging)

Housing Features

Housing Material	Polyamide
------------------	-----------

Dimensions

Length	22.9 mm[.9 in]
--------	----------------

Usage Conditions

Operating Temperature Range	-40 – 105 °C[-40 – 221 °F]
-----------------------------	----------------------------

Packaging Features

Packaging Quantity	11000
Packaging Method	Carton

Product Compliance

[For compliance documentation, visit the product page on TE.com>](#)

EU RoHS Directive 2011/65/EU	Compliant
EU ELV Directive 2000/53/EC	Compliant
China RoHS 2 Directive MIIT Order No 32, 2016	No Restricted Materials Above Threshold
EU REACH Regulation (EC) No. 1907/2006	Current ECHA Candidate List: JUNE 2022 (224) Candidate List Declared Against: JAN 2022 (223) SVHC > Threshold: Not Yet Reviewed
Halogen Content	Low Halogen - Br, Cl, F, I < 900 ppm per homogenous material. Also BFR/CFR/PVC Free
Solder Process Capability	Not applicable for solder process capability

Product Compliance Disclaimer

This information is provided based on reasonable inquiry of our suppliers and represents our current actual knowledge based on the information they provided. This information is subject to change. The part numbers that TE has identified as EU RoHS compliant have a maximum concentration of 0.1% by weight in homogenous materials for lead, hexavalent chromium, mercury, PBB, PBDE, DBP, BBP, DEHP, DIBP, and 0.01% for cadmium, or qualify for an exemption to these limits as defined in the Annexes of Directive 2011/65/EU (RoHS2). Finished electrical and electronic equipment products will be CE marked as required by Directive 2011/65/EU. Components may not be CE marked. Additionally, the part numbers that TE has identified as EU ELV compliant have a maximum concentration of 0.1% by weight in homogenous materials for lead, hexavalent chromium, and mercury, and 0.01% for cadmium, or qualify for an exemption to these limits as defined in the Annexes of Directive 2000/53/EC (ELV). Regarding the REACH Regulation, the information TE provides

on SVHC in articles for this part number is based on the latest European Chemicals Agency (ECHA) 'Guidance on requirements for substances in articles' posted at this URL: <https://echa.europa.eu/guidance-documents/guidance-on-reach>

Compatible Parts



TE Part # 170258-2
FF 250 REC 14-12AWG TPBR REREELING



TE Part # 170258-1
FF 250 REC 14-12AWG BR REREELING



TE Part # 180905-1
FF 250 REC HSG 1P NYLON RED



TE Part # 180918
FF 250 REC HSG 2P NYLON CLEAR



TE Part # 880191-1
5W FASTIN-ON REC. H



TE Part # 925306-2
FF 312 REC HSG 3P NYLON CLEAR

Also in the Series | FASTIN-FASTON 250

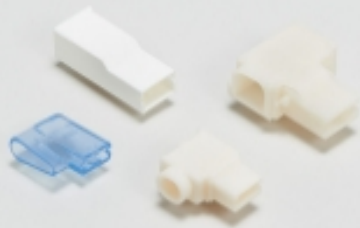

Crimp Terminal Housings(218)



Insertion & Extraction Tools(2)



PCB Terminals(2)



Quick Disconnects(255)

Customers Also Bought



TE Part #130230
SOLIS R 12-10 6MM

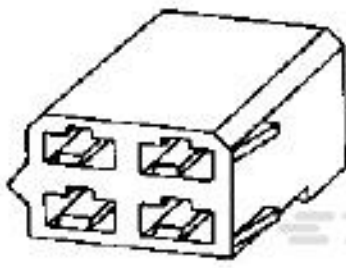

TE Part #180900
FF 250 REC HSG 4P NYLON NAT

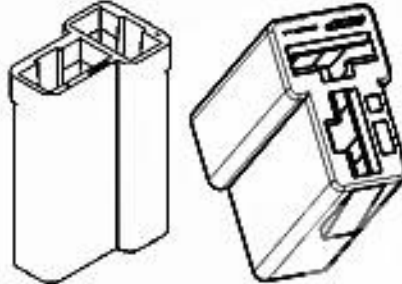

TE Part #180907
FF 250 REC HSG 2P NYLON NAT



TE Part #160743-4
110 FASTIN FASTON,TAB,20-16 AWG, PTBR



Documents

Product Drawings

[FF 250 REC HSG 1P NYLON NAT](#)

English

CAD Files

[3D PDF](#)

3D

Customer View Model

[ENG_CVM_CVM_180905_AB.2d_dxf.zip](#)

English

Customer View Model

[ENG_CVM_CVM_180905_AB.3d_igs.zip](#)

English

Customer View Model

[ENG_CVM_CVM_180905_AB.3d_stp.zip](#)

English

By downloading the CAD file I accept and agree to the [Terms and Conditions](#) of use.

Datasheets & Catalog Pages

[White Paper: Nylon Discoloration](#)

English

Product Specifications

[Application Specification](#)

English

Product Environmental Compliance

[TE Material Declaration](#)

180905

Crimp Terminal Housings, Receptacle, Receptacle, 1 Position, Straight, Natural, Polyamide, Mating Alignment, FASTIN-FASTON 250



English