

| LOC | | DIST | | REVISIONS | | | |
|-----|----|----------------------|---------|-----------|------|--|--|
| P | LR | DESCRIPTION | DATE | DRN | APVD | | |
| C | | REV PER 063H-0177-04 | 01OCT04 | JR | GJ | | |

- SPECIFICATIONS: MAGNET WIRE RANGE; #18-#34
 .006-.040 DIA [0.16-1.02] mm.
 OTHER SIZES MAY BE ACCOMMODATED, CONSULT
 TYCO ELECTRONICS FOR APPROVAL.
- POCKET RECOMMENDATION: 1601424.
- MAINTAIN THICKNESS FOR THIS LENGTH AND COIN
 EDGES WITH NO BURRS.
- SELECTIVE PLATE THIS AREA: .000050 [0.00127] MIN GOLD
 OVER .000050 [0.00127] MIN NICKEL UNDERPLATE OVER
 ENTIRE TERMINAL.
- PRELIMINARY - NOT FOR PRODUCTION

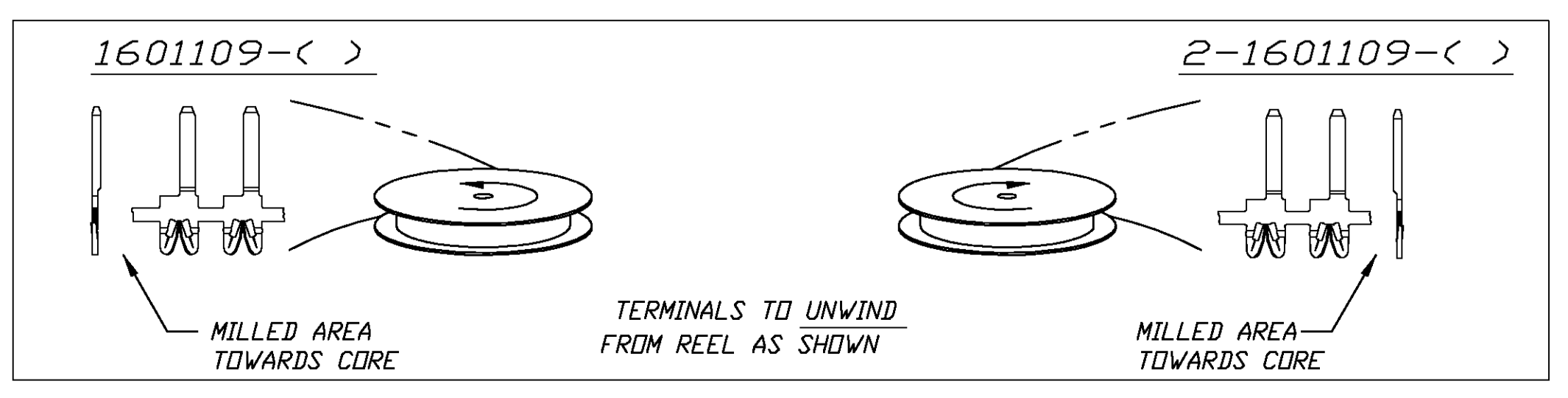
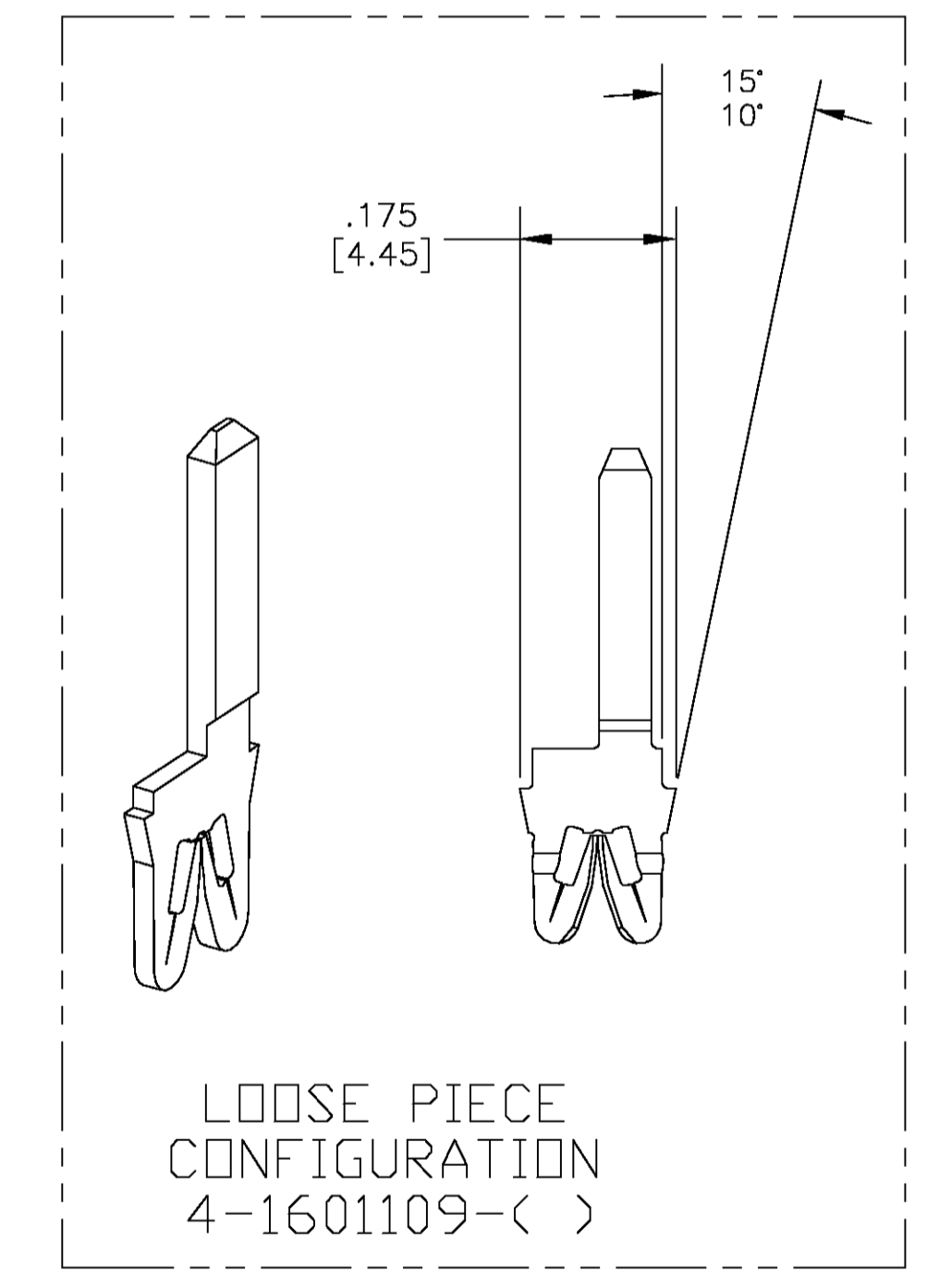
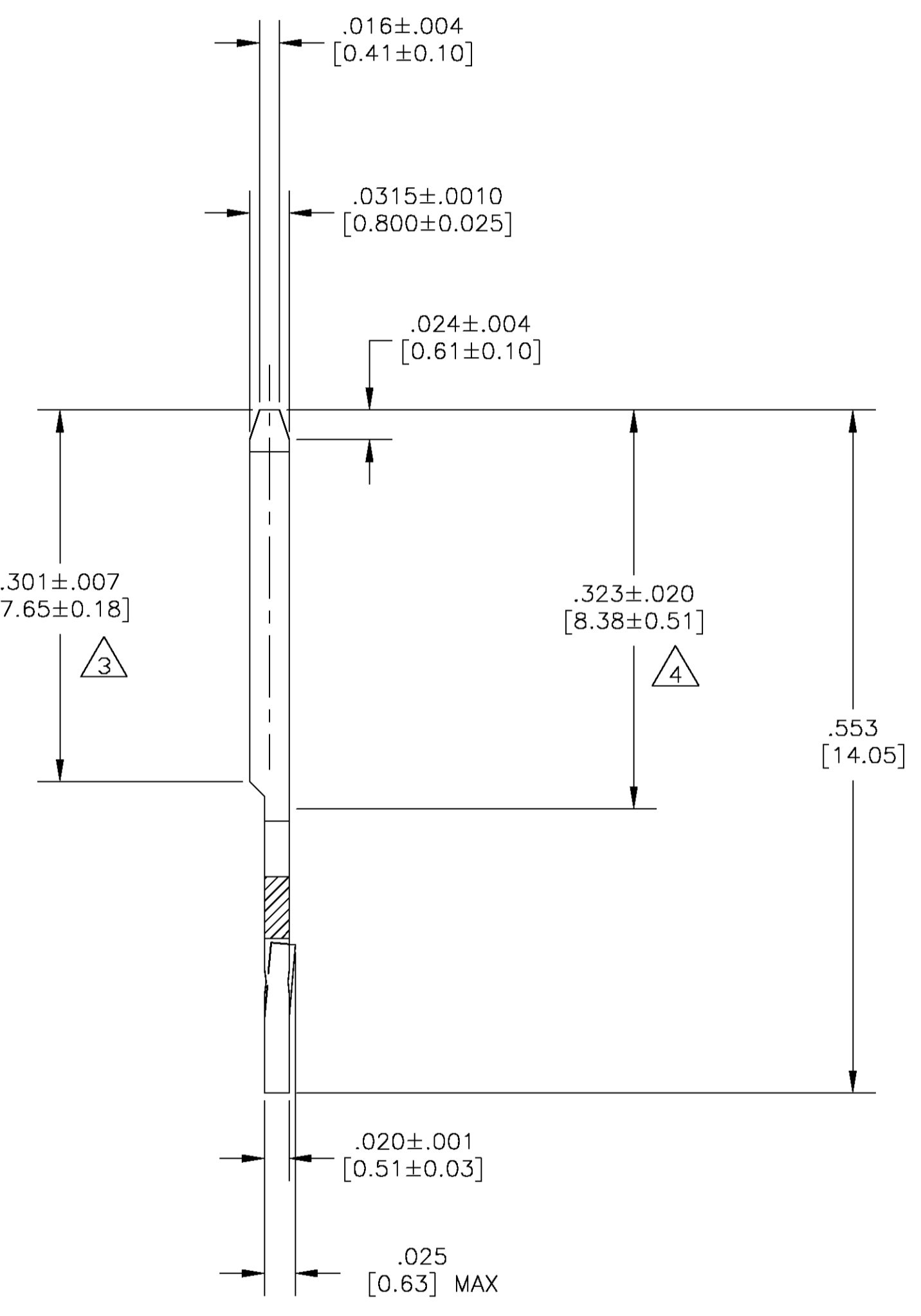
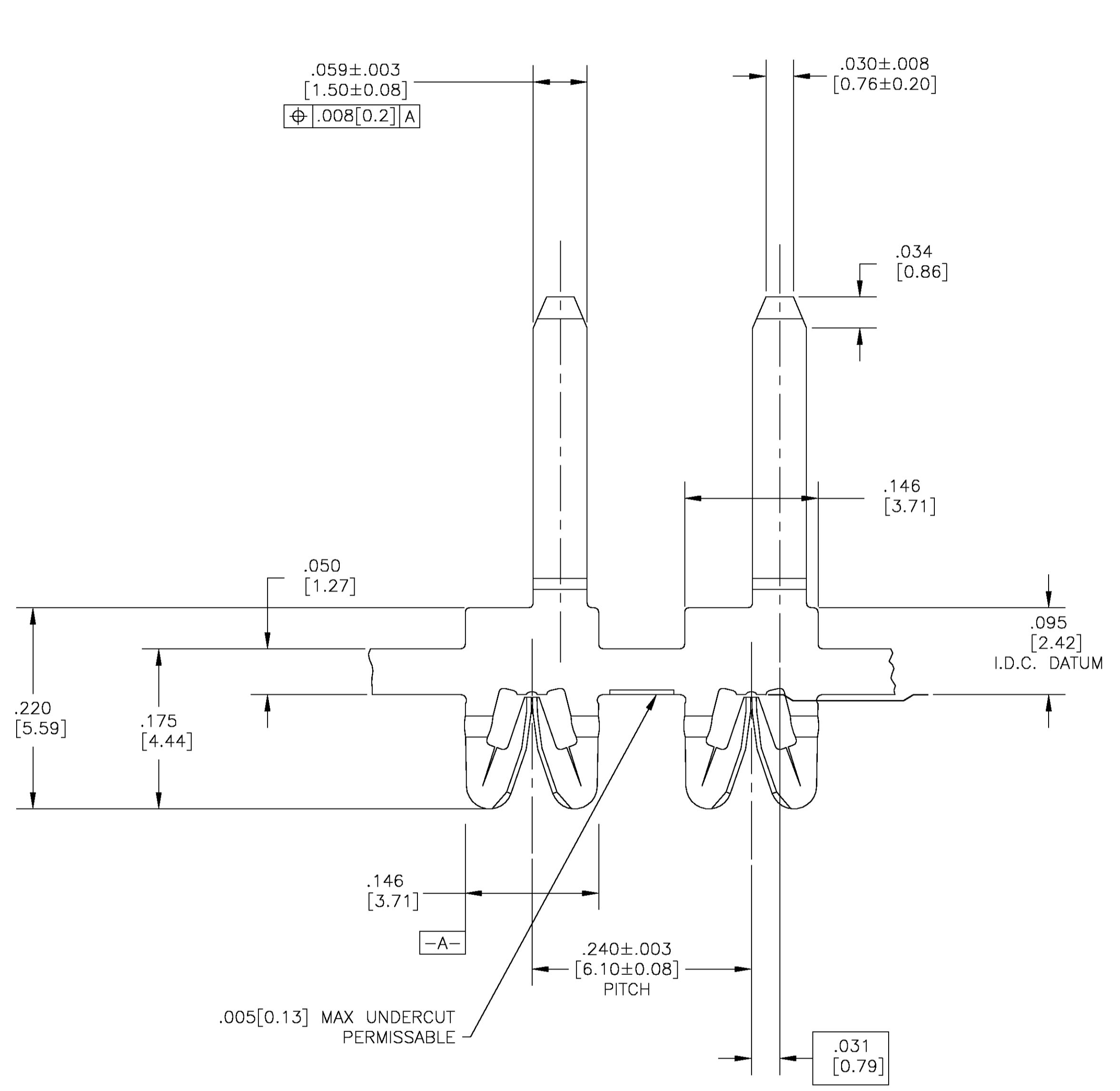

| | |
|----------|-------------|
| UNPLATED | 4-1601109-2 |
| UNPLATED | 4-1601109-1 |
| UNPLATED | 2-1601109-1 |
| UNPLATED | 1601109-2 |
| UNPLATED | 1601109-1 |
| FINISH | PART NUMBER |

| | | | | | |
|--|--|--------------------------------|--|------------------------------|--|
| THIS DRAWING IS A CONTROLLED DOCUMENT. | | DIN MICHAEL S. FEHER 28NOV2002 | | Tyco Electronics Corporation | |
| DIMENSIONS: INCHES | | CHK GENE JACOPO 28NOV2002 | | Harriaburg, PA 17105-3608 | |
| TOLERANCES UNLESS OTHERWISE SPECIFIED: | | APVD GENE JACOPO 28NOV2002 | | NAME .059 X .032 OFFSET TAB | |
| 0 PLC ± - | | PRODUCT SPEC 108-2085 | | STANDARD SIAMEZE TERMINAL | |
| 1 PLC ± - | | APPLICATION SPEC 408-8629 | | SIZE A1 | |
| 2 PLC ± .01(0.25) | | MATERIAL BRASS, FULL HARD | | CAGE CODE 00779 | |
| 3 PLC ± .005(0.13) | | FINISH SEE TABLE | | DRAWING NO 1601109 | |
| 4 PLC ± ± Z | | WEIGHT - | | RESTRICTED TO - | |
| ANGLES ± ± Z | | CUSTOMER DRAWING | | SCALE 10:1 | |
| | | | | SHEET 1 OF 1 | |
| | | | | REV G | |