

160914-4 ✓ ACTIVE

FASTIN-FASTON | FASTIN-FASTON 250

TE Internal #: 160914-4

Quick Disconnects, Receptacle, 11 – 10 AWG Wire Size, 4 – 5.2 mm<sup>2</sup> Wire Size, Mating Tab Width .25 in [6.35 mm], Straight, FASTIN-FASTON 250

[View on TE.com >](#)



Terminals & Splices > Quick Disconnects



Quick Disconnect Terminal Type: **Receptacle**

Wire Size: **4 – 5.2 mm<sup>2</sup>**

Mating Tab Width: **6.35 mm [ .25 in ]**

Mating Tab Thickness: **.81 mm [ .032 in ]**

## Features

### Product Type Features

Terminates To	Wire & Cable
Wire/Cable Type	Regular Wire
Wire Stop	No
Insertion Force	Normal
Sealable	No

### Configuration Features

Connection Capacity	Single
---------------------	--------

### Contact Features

Quick Disconnect Terminal Type	Receptacle
Mating Tab Width	6.35 mm [.25 in]
Mating Tab Thickness	.81 mm [.032 in]
Terminal Orientation	Straight
Contact Base Material	Phosphor Bronze
Terminal Plating Material	Tin
Crimp Type	F-Crimp



Barrel Type	Open
-------------	------

### Mechanical Attachment

Mating Retention Type	Locking Lance
	.053 in

Wire Insulation Support	With
-------------------------	------

### Dimensions

Accepts Wire Insulation Diameter Range	4 – 5.2 mm [.157 – .205 in]
--	-----------------------------

Receptacle Terminal Stock Thickness	.41 mm [.016 in]
-------------------------------------	------------------

Overall Length	19.2 mm [.755 in]
----------------	-------------------

Wire Size	4 – 5.2 mm <sup>2</sup>
-----------	-------------------------

### Usage Conditions

Insulation Option	Uninsulated
-------------------	-------------

Operating Temperature Range	-40 – 110 °C [-40 – 230 °F]
-----------------------------	-----------------------------

### Industry Standards

UL Flammability Rating	UL 94V-2
------------------------	----------

### Packaging Features

Packaging Quantity	4000
--------------------	------

Packaging Method	Strip/Reel
------------------	------------

### Other

Comment	Chamfered, With dimple
---------	------------------------

### Product Compliance

[For compliance documentation, visit the product page on TE.com>](#)

EU RoHS Directive 2011/65/EU	Compliant
------------------------------	-----------

EU ELV Directive 2000/53/EC	Compliant
-----------------------------	-----------

China RoHS 2 Directive MIIT Order No 32, 2016	No Restricted Materials Above Threshold
---	---

EU REACH Regulation (EC) No. 1907/2006	Current ECHA Candidate List: JUNE 2022 (224) Candidate List Declared Against: JAN 2022 (223) SVHC > Threshold: Not Yet Reviewed
--	--

Halogen Content	Low Halogen - Br, Cl, F, I < 900 ppm per homogenous material. Also BFR/CFR/PVC
-----------------	--

Free

Solder Process Capability

Not applicable for solder process capability

Product Compliance Disclaimer

This information is provided based on reasonable inquiry of our suppliers and represents our current actual knowledge based on the information they provided. This information is subject to change. The part numbers that TE has identified as EU RoHS compliant have a maximum concentration of 0.1% by weight in homogenous materials for lead, hexavalent chromium, mercury, PBB, PBDE, DBP, BBP, DEHP, DIBP, and 0.01% for cadmium, or qualify for an exemption to these limits as defined in the Annexes of Directive 2011/65/EU (RoHS2). Finished electrical and electronic equipment products will be CE marked as required by Directive 2011/65/EU. Components may not be CE marked. Additionally, the part numbers that TE has identified as EU ELV compliant have a maximum concentration of 0.1% by weight in homogenous materials for lead, hexavalent chromium, and mercury, and 0.01% for cadmium, or qualify for an exemption to these limits as defined in the Annexes of Directive 2000/53/EC (ELV). Regarding the REACH Regulation, the information TE provides on SVHC in articles for this part number is based on the latest European Chemicals Agency (ECHA) 'Guidance on requirements for substances in articles' posted at this URL: <https://echa.europa.eu/guidance-documents/guidance-on-reach>

## Compatible Parts



TE Part # 1-1579007-4  
EXTRACTION TOOL



TE Part # 4-1579007-3  
EXTRACTION TOOL KIT



TE Part # 151667-2  
FF 375 REC 4-6MM2 TPBR



TE Part # 539745-2  
DIE F6.3FF REC.



TE Part # 151667-4  
FF 375 REC TERMINAL 11-10 AWG PBR



TE Part # 160920-4  
FF 312 REC 2.5-4MM2 TPPB



TE Part # 2-2150402-1  
OCEAN-2.0-APPLICATOR-E-160F220F



TE Part # 2-2150402-2  
OCEAN-2.0-APPLICATOR-E-160F220F



TE Part # 2150402-1  
OCEAN-2.0-APPLICATOR-E-160F220F



TE Part # 2150402-2  
OCEAN-2.0-APPLICATOR-E-160F220F



TE Part # 7-2150402-7  
OCEAN\_2.0\_SPARE\_PART\_KIT-160F220F

Also in the Series | **FASTIN-FASTON 250**

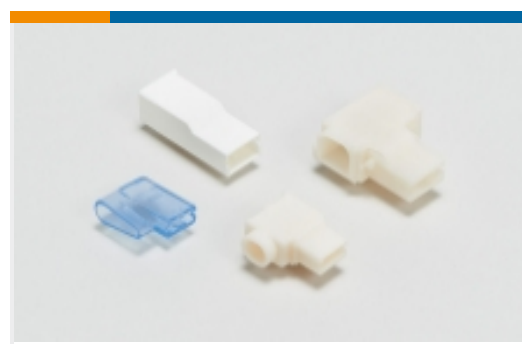

Crimp Terminal Housings(218)



Insertion &amp; Extraction Tools(2)



PCB Terminals(2)

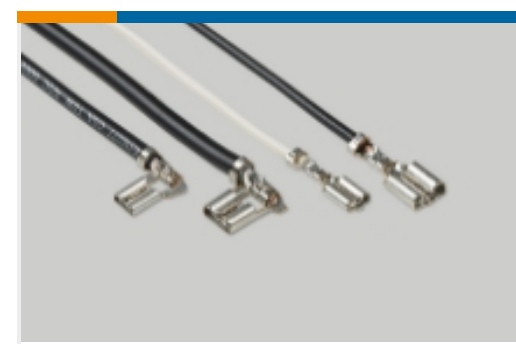

Quick Disconnects(255)

## Customers Also Bought

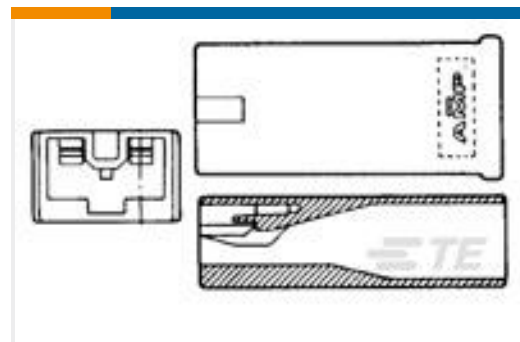
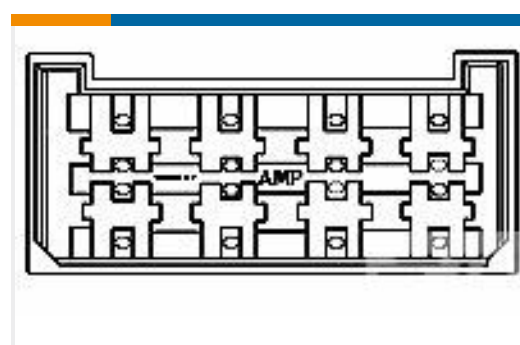
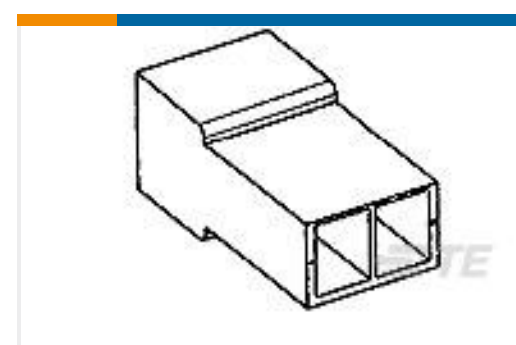
TE Part #160533-2  
110 FASTON,REC.,20-17 AWG,TPBRTE Part #179970-1  
250 HSG. PL EX REC.TE Part #179974-1  
250 PL EX REC. 18-14AWG PTBRTE Part #HD10-9-1939P-B022  
RECP ASMTE Part #1-1703543-0  
2POS,TAB 2.8X0.8,TAB HSG,ASSYTE Part #280099  
FF 250 TAB HSG 8P NYLON CLEARTE Part #3-180916-0  
FF 250 TAB HSG 1P NYLON NATTE Part #280542  
FF 250 TAB HSG 2P NYLON NAT

## Documents

### Product Drawings

[FF 250 REC 4-6MM2 TPPB](#)

English

### CAD Files

[3D PDF](#)

3D

Customer View Model

[ENG\\_CVM\\_CVM\\_160914-4\\_M.2d\\_dxf.zip](#)

English

Customer View Model

[ENG\\_CVM\\_CVM\\_160914-4\\_M.3d\\_igs.zip](#)

English

Customer View Model

[ENG\\_CVM\\_CVM\\_160914-4\\_M.3d\\_stp.zip](#)

English

By downloading the CAD file I accept and agree to the [Terms and Conditions](#) of use.



---

[Product Specifications](#)

[Application Specification](#)

German