

SYMBOL DEFINITION		MISSING SYMBOLS	
A DIMENSION WITHOUT AN INSPECTION REPORT SYMBOL  DOES NOT REQUIRE INSPECTION. IT MAY BE CONTROLLED ON THE INDIVIDUAL COMPONENT DRAWING.	TOTAL NO OF INSPECTIONS REQUIRED	NO MISSING SYMBOL NUMBER	
	2		
	LAST NO. USED		
	2		

DWG STATUS					REVISION HISTORY					
DATE	STG	REV	N/P	CHG	ZONE		AUTH	DR	APVD 1	APVD 2
06FE01	R	001	-	-		RELEASED	197292	JCH	JCH	JMW
23AP02	R	01	AA	-		BASE TERMINAL REVISED; PRINT MATCH PART	224463	PJC	PJC	JMW
07N002	R	01	AB	-		REMOVED NOTE #3	233205	PJC	PJC	RAT
01MY03	R	01	AC	-		REMOVED NOTE #3	240578	PJC	PJC	RAT
090C03	R	01	AD	-		ADDED NOTE #3	247257	PJC	PJC	RAT
10JA05	R	01	AE	-		ADDED NOTE #4	263091	PJC	PJC	RAT
24JA06	R	01	AF	-		REMOVED NOTE 3; RENUMBERED NOTE 4 TO 3	276701	PJC	PJC	PJC
01FE06	R	01	AG	-		3.16±0.15 WAS 3.16	276952	PJC	PJC	PJC

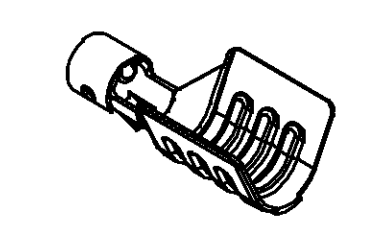
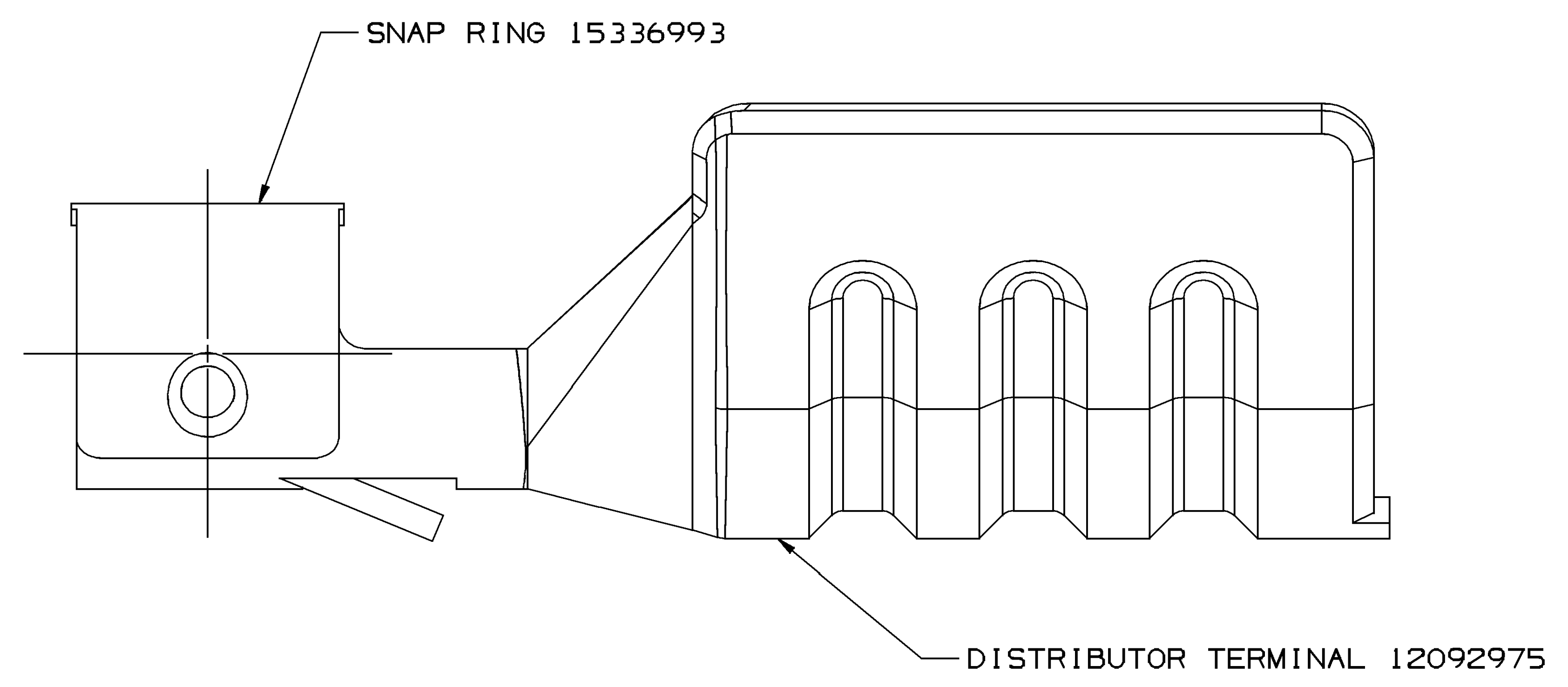
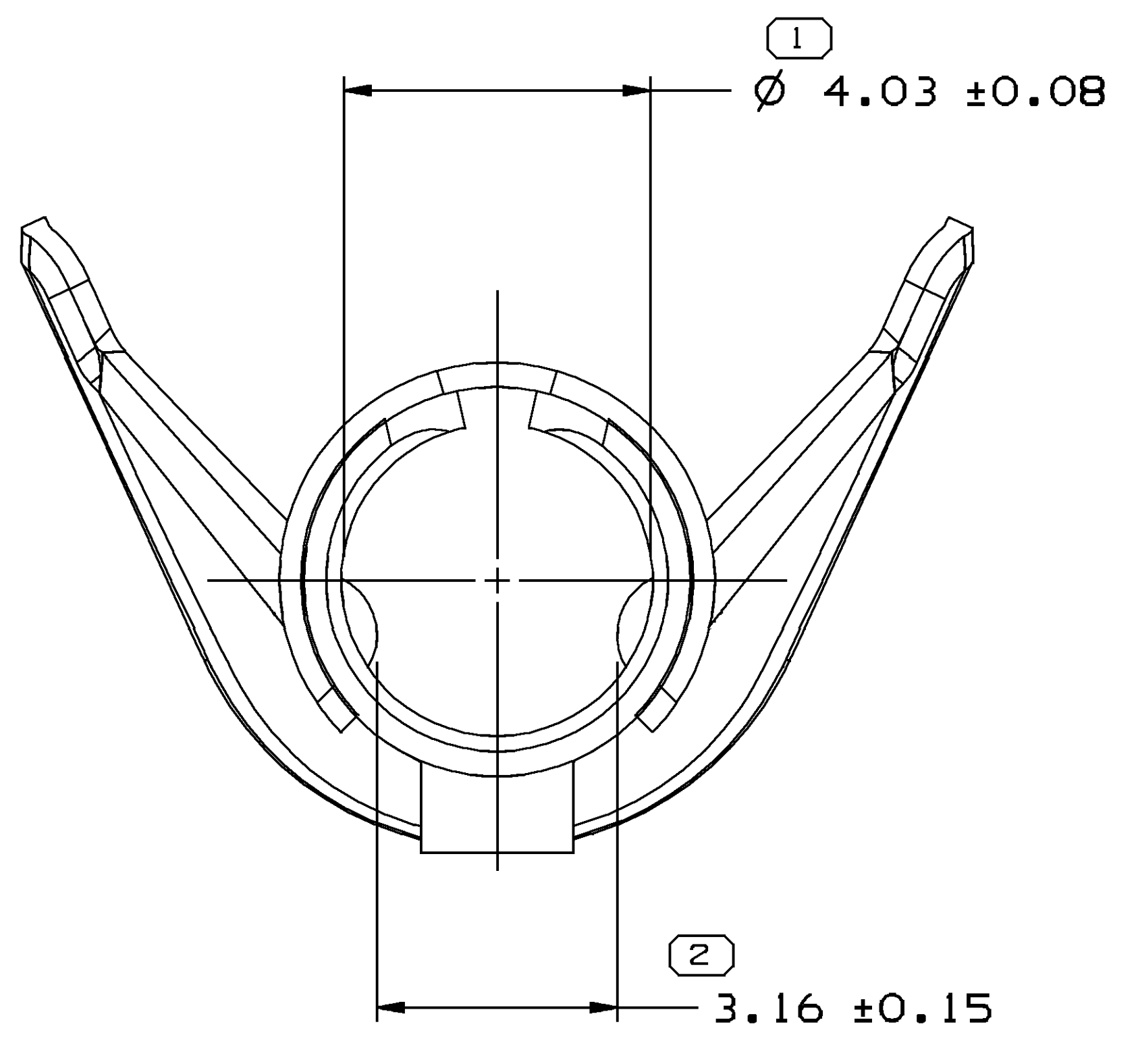
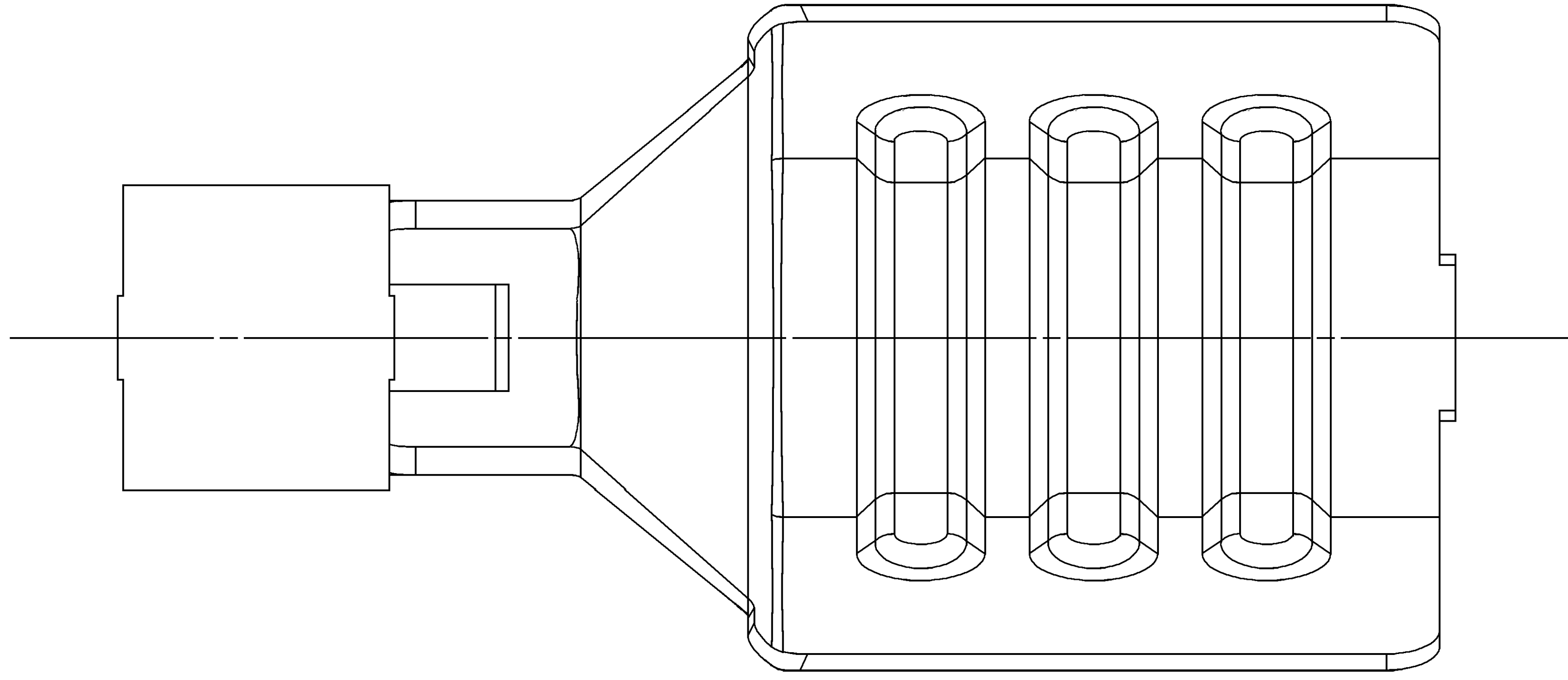

SCALE 1:1

NOTES:

1. THIS PART IS NOT CONTROLLED FOR AUTOMATIC FEEDING.
2. UNLESS OTHERWISE SPECIFIED AND/OR INDICATED: DIMENSIONS ARE TO FACE OF VIEW SHOWN AND AUTOMATICALLY ROUNDED BY COMPUTER FOR INSPECTION. (SEE MATH MODEL FOR PRECISE DIMENSION) FOR ALL OTHER DIMENSIONS NOT SHOWN BUT REQUIRED FOR TOOL BUILD, SEE MATH MODEL FOR PRECISE TOOL PATH DATA.
3. SPLICE LABELS MUST BE USED TO IDENTIFY SPLICES WITHIN A REEL. USE NON-METAL SPLICES ONLY.

DIMENSIONAL RANGE (MM)	CHART D
FROM 0	> 12
TO 12	
TOLERANCE UNLESS OTHERWISE SPECIFIED	
±0.1	±0.2
ANGULAR TOLERANCE ±2°	

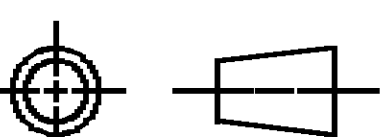
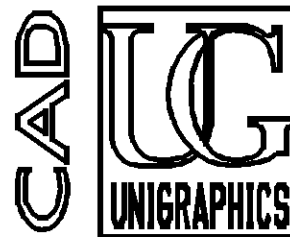
DWG TYPE PART DRAWING	
STYLE	
VOLUME (C/P)	DISTR CODE D
UNLESS OTHERWISE SPECIFIED THIS DOCUMENT IS IN ACCORDANCE WITH ASME Y14.5M-1994 AS AMENDED BY THE 2003 GLOBAL DIMENSIONING AND TOLERANCING ADDENDUM - 1997. ALL GEOMETRIC TOLERANCES AND RELATED DATUMS APPLY RFS. RULE #1 (PERFECT FORM AT ALL TIMES) DOES NOT APPLY WHEN RELATIONSHIP BETWEEN FEATURES IS ESTABLISHED BY ORIENTATION OR LOCATION TOLERANCES. SEPARATE POSITION CALLOUTS MAY BE GAGED SEPARATELY, REGARDLESS OF DATUM REFERENCE. ALL DIMENSIONS ARE IN MILLIMETERS	
REFERENCE	001
THIRD ANGLE PROJECTION	DO NOT SCALE
	USE MATH DATA
	

DELPHI			
DELPHI PACKARD ELECTRIC SYSTEMS WARREN, OH			
DR	JAMES C HOLMES	DATE	06FE01
APVD1	JAMES C HOLMES		06FE01
APVD2	JAMES C HOLMES		06FE01
APVD3	JAMES WESTON		06FE01
APVD4			
APVD5			
SUBSTANCES OF CONCERN AND RECYCLED CONTENT PER DELPHI-A 10949001			
MATERIAL SEE DRAWING			
DRAWING NAME ASM TERM 1GN 7MM			
DRAWING NUMBER 15336994			
SIZE	SCALE	FRAME NO	SHEET NO
A1	10:1	1 OF 1	1 OF 1
STG	REV	N/P	AG
R	01		