

141628-4 ✓ ACTIVE

FASTON | FASTON 110

TE Internal #: 141628-4

Crimp Terminal Housings, Receptacle, Receptacle, 1 Position,  
Straight, UL 94V-2, Black, Polyamide, Mating Alignment, FASTON  
110

[View on TE.com >](#)



Terminals & Splices > Terminal Housings, Insulation Sleeves & Blocks > Crimp Terminal Housings



Terminal Type: **Receptacle**

Housing Type: **Receptacle**

Number of Positions: **1**

Terminal Orientation: **Straight**

UL Flammability Rating: **UL 94V-2**

## Features

### Product Type Features

Product Type	Terminal Housing
Sealable	No
Housing Type	Receptacle
Insulated	No

### Configuration Features

Number of Positions	1
---------------------	---

### Body Features

Primary Product Color	Black
-----------------------	-------

### Contact Features

Terminal Type	Receptacle
Terminal Orientation	Straight
Contact Mating Retention	Without

### Mechanical Attachment



Mating Alignment	With
Crimp Terminal Housing Mounting Style	Cable Mount (Free-Hanging)

### Housing Features

Housing Material	Polyamide
------------------	-----------

### Dimensions

Length	21.1 mm[.83 in]
--------	-----------------

### Usage Conditions

Operating Temperature Range	-40 – 105 °C[-40 – 221 °F]
-----------------------------	----------------------------

### Industry Standards

UL Flammability Rating	UL 94V-2
------------------------	----------

### Packaging Features

Packaging Quantity	15000
Packaging Method	Carton

## Product Compliance

[For compliance documentation, visit the product page on TE.com>](#)

EU RoHS Directive 2011/65/EU	Compliant
EU ELV Directive 2000/53/EC	Compliant
China RoHS 2 Directive MIIT Order No 32, 2016	No Restricted Materials Above Threshold
EU REACH Regulation (EC) No. 1907/2006	Current ECHA Candidate List: JUNE 2022 (224) Candidate List Declared Against: JAN 2022 (223) SVHC > Threshold: Not Yet Reviewed
Halogen Content	Low Halogen - Br, Cl, F, I < 900 ppm per homogenous material. Also BFR/CFR/PVC Free
Solder Process Capability	Not applicable for solder process capability

#### Product Compliance Disclaimer

This information is provided based on reasonable inquiry of our suppliers and represents our current actual knowledge based on the information they provided. This information is subject to change. The part numbers that TE has identified as EU RoHS compliant have a maximum concentration of 0.1% by weight in homogenous materials for lead, hexavalent chromium, mercury, PBB, PBDE, DBP, BBP, DEHP, DIBP, and 0.01% for cadmium, or qualify for an exemption to these limits as defined in the Annexes of Directive 2011/65/EU (RoHS2). Finished electrical and electronic equipment products will be CE marked as required by Directive 2011/65/EU. Components may not be CE marked. Additionally, the part numbers that TE has identified as EU ELV compliant have a maximum concentration of 0.1% by weight in homogenous materials for lead, hexavalent chromium, and mercury, and 0.01% for cadmium, or qualify for an exemption to these limits

as defined in the Annexes of Directive 2000/53/EC (ELV). Regarding the REACH Regulation, the information TE provides on SVHC in articles for this part number is based on the latest European Chemicals Agency (ECHA) 'Guidance on requirements for substances in articles' posted at this URL: <https://echa.europa.eu/guidance-documents/guidance-on-reach>

## Compatible Parts



TE Part # 5-160321-2  
FASTON 110 REC 22-20 AWG  
ELECTRO TPBR



TE Part # 280311-5  
FASTON 375 IS NYLON BLK

## Also in the Series | FASTON 110

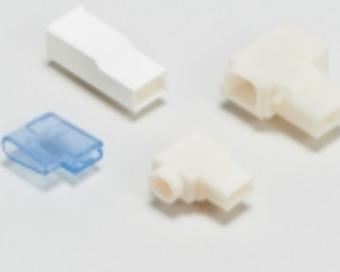

Crimp Terminal Housings(17)



Insertion & Extraction Tools(1)



PCB Terminals(21)



Quick Disconnects(173)

## Customers Also Bought



TE Part #DT06-2S  
DEUTSCH DT Series Housings & Connectors



TE Part #W2S  
DEUTSCH DT WEDGELOCKS

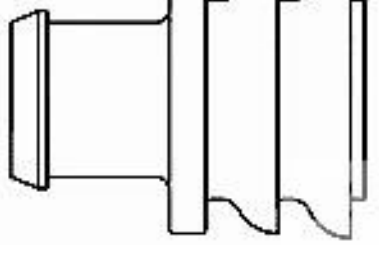

TE Part #281934-2  
SINGLE WIRE SEAL



TE Part #0460-202-16141  
DEUTSCH SOLID CONTACTS



TE Part #282104-1  
AMP SUPERSEAL 1.5MM,  
CONNECTOR HOUSING



TE Part #114017-ZZ  
SEALING PLUG, SIZE 12/16, WHT

## Documents



### Product Drawings

[110 FASTON HSG.,REC.,1 POS,BLACK](#)

English

---

### CAD Files

[3D PDF](#)

English

**Customer View Model**

[ENG\\_CVM\\_141628-4\\_H.2d\\_dxf.zip](#)

English

**Customer View Model**

[ENG\\_CVM\\_141628-4\\_H.3d\\_igs.zip](#)

English

**Customer View Model**

[ENG\\_CVM\\_141628-4\\_H.3d\\_stp.zip](#)

English

[3D PDF](#)

3D

**Customer View Model**

[ENG\\_CVM\\_CVM\\_141628-4\\_J.2d\\_dxf.zip](#)

English

**Customer View Model**

[ENG\\_CVM\\_CVM\\_141628-4\\_J.3d\\_igs.zip](#)

English

**Customer View Model**

[ENG\\_CVM\\_CVM\\_141628-4\\_J.3d\\_stp.zip](#)

English

By downloading the CAD file I accept and agree to the [Terms and Conditions](#) of use.

---

### Product Specifications

[.110,.187 & 250 Series FASTON Terminals](#)

English

[Product Specification](#)

English