

THIS DRAWING IS UNPUBLISHED. RELEASED FOR PUBLICATION
 © COPYRIGHT - BY TYCO ELECTRONICS CORPORATION. ALL RIGHTS RESERVED.

LOC	DIST	REVISIONS					
G	14	P	LTR	DESCRIPTION	DATE	DWN	APVD
			B	REV PER ECR 07-023034	12NOV07	JR	TM

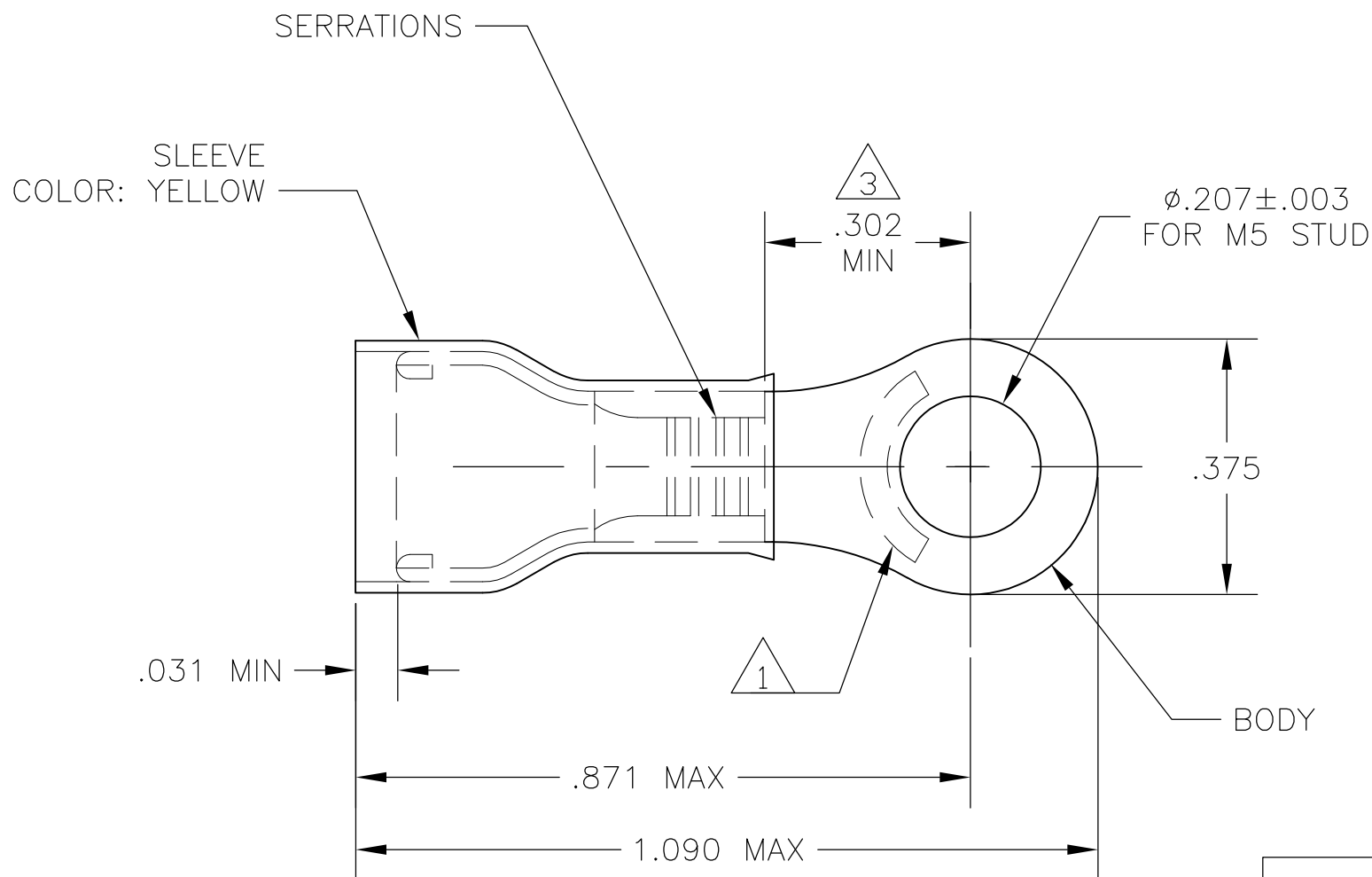

- 1 STAMP "AMP 12-10*", LOCATION APPROX AS SHOWN.
- 2 TONGUE THICKNESS IS $.039 \pm .002$
- 3 APPLIES TO EDGE OF METAL WIRE BARREL TO CENTER OF STUD HOLE.
- 4 FOR AMP BRAZIL PRODUCTION ONLY
- 5 BODY - COPPER PER ASTM B-152 SLEEVE - COPPER PER ASTM B-152 INSULATION - NYLON
- 6 BODY - TIN PL PER ASTM B-545 SLEEVE - TIN PL PER ASTM B-545 INSULATION - COLOR - YELLOW
- 7 105°C MAX OPERATING TEMPERATURE.
- 8 300 VOLT MAX
- 9 2.62-6.64mm² [5,180 - 13,100 CMA] SOLID OR STRANDED

WIRE INSULATION OD RANGE	QTY	PACKAGE TYPE	PART NO
.150-.250	25	LOOSE PIECE	8-130171-1
.150-.250	2500	REELED ON TAPE	2-130171-1
.170-.300	-	LOOSE PIECE	4 130171-1
.150-.250	500	LOOSE PIECE	130171

THIS DRAWING IS A CONTROLLED DOCUMENT.		DWN jr_ruth 20FEB06	Tyco Electronics Corporation Harrisburg, PA 17105-3608	
DIMENSIONS: INCHES		CHK T MICHIELUTTI 20FEB06	NAME TERMINAL RING TONGUE, PIDG, WIRE SIZE 12:10	
TOLERANCES UNLESS OTHERWISE SPECIFIED:		APVD T MICHIELUTTI 20FEB06	PRODUCT SPEC	
0 PLC ± - 1 PLC ± - 2 PLC ± - 3 PLC ± .008 4 PLC ± - ANGLES ± 5°		APPLICATION SPEC		
MATERIAL	FINISH	WEIGHT	SIZE	CAGE CODE
5	6	-	A3	00779
CUSTOMER DRAWING			DRAWING NO	RESTRICTED TO
			G-130171	-
			SCALE	SHEET
			4:1	1 OF 1
			REV	B