

REV	DATE	DESCRIPTION	BY	CHK	APPD
N4	SEE PCN-E-15-007677		19MAY2015	JR	HR
N5	SEE PCN-E-17-001532		09FEB2017	KC	SH
N6	SEE PCN-E-18-005619		19APR2018	RS	-

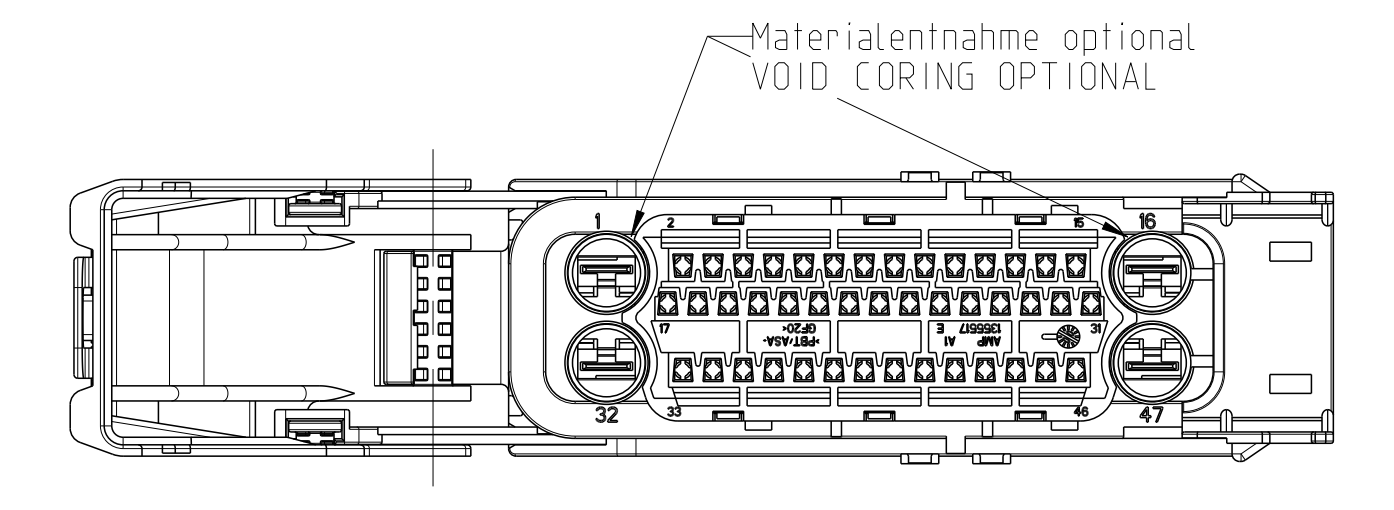

CONNECTOR WITH OPENED SHIELD

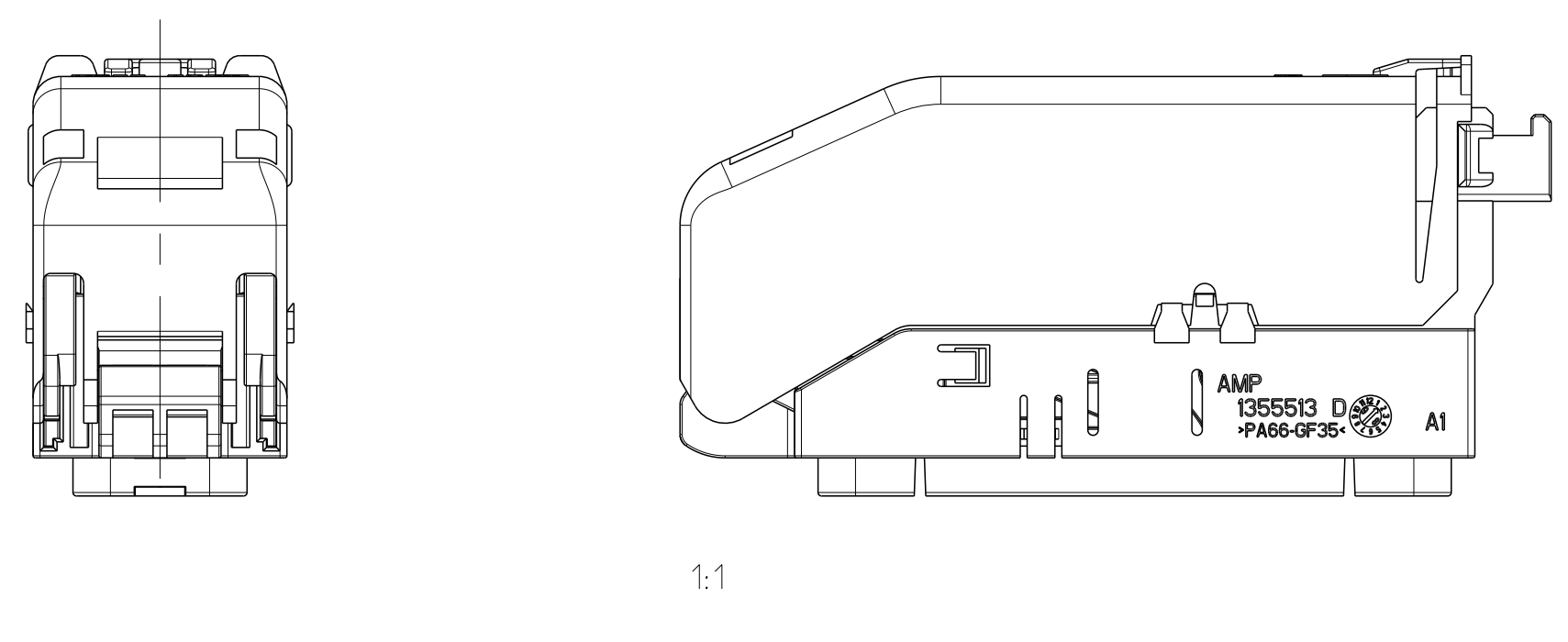
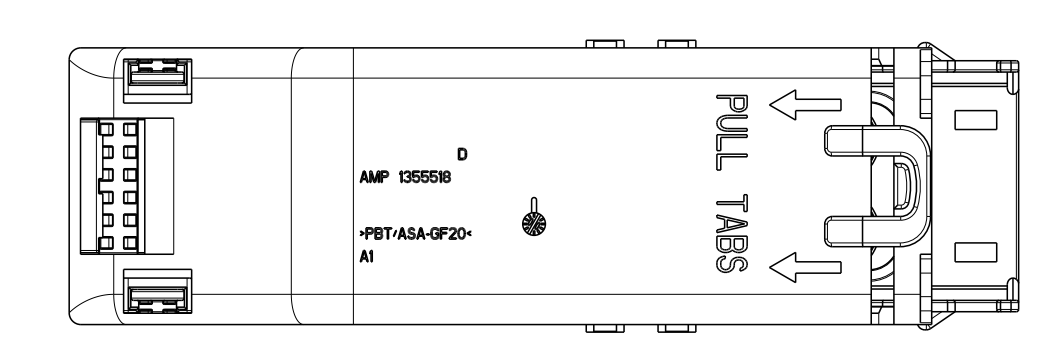
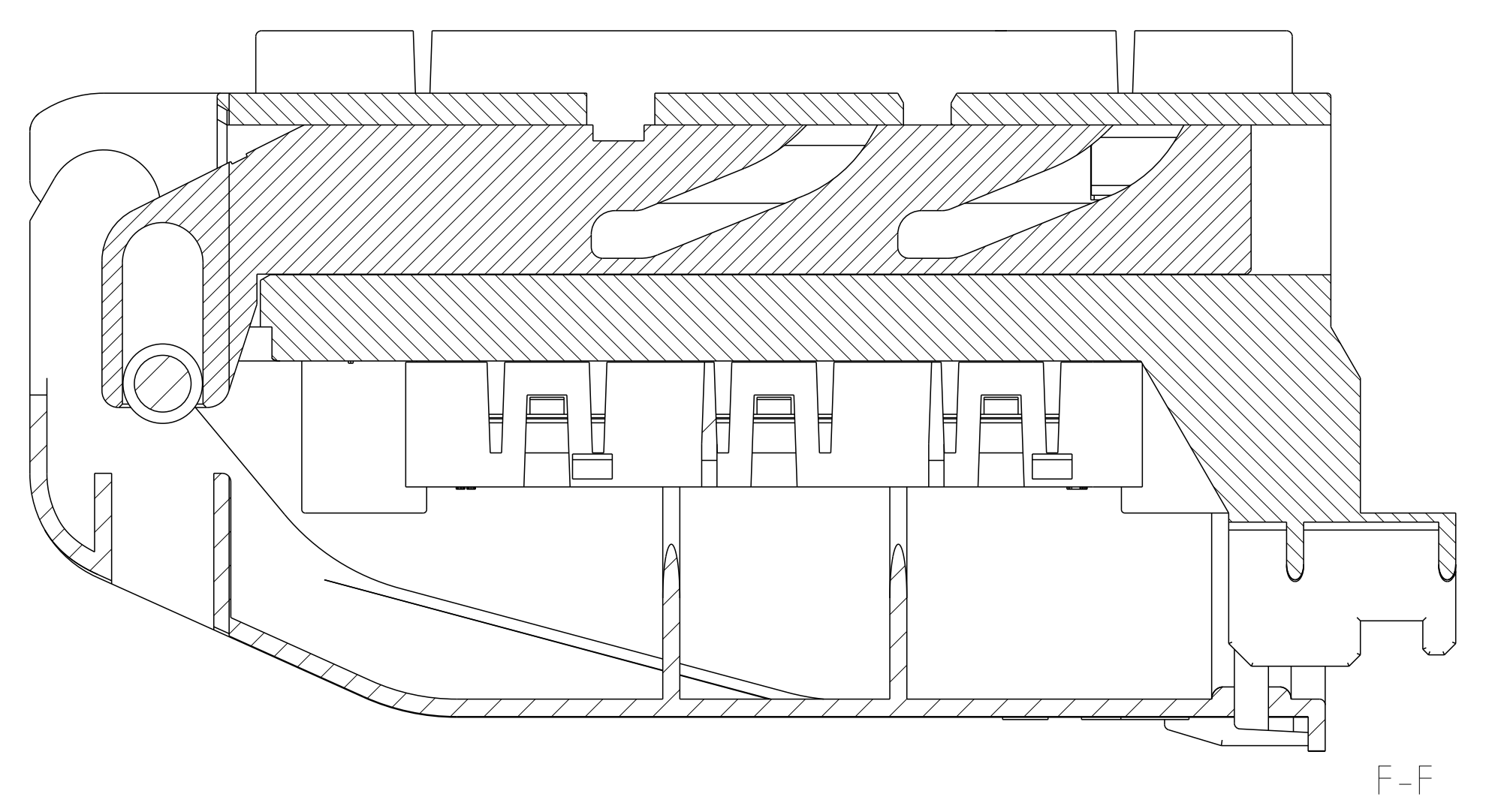
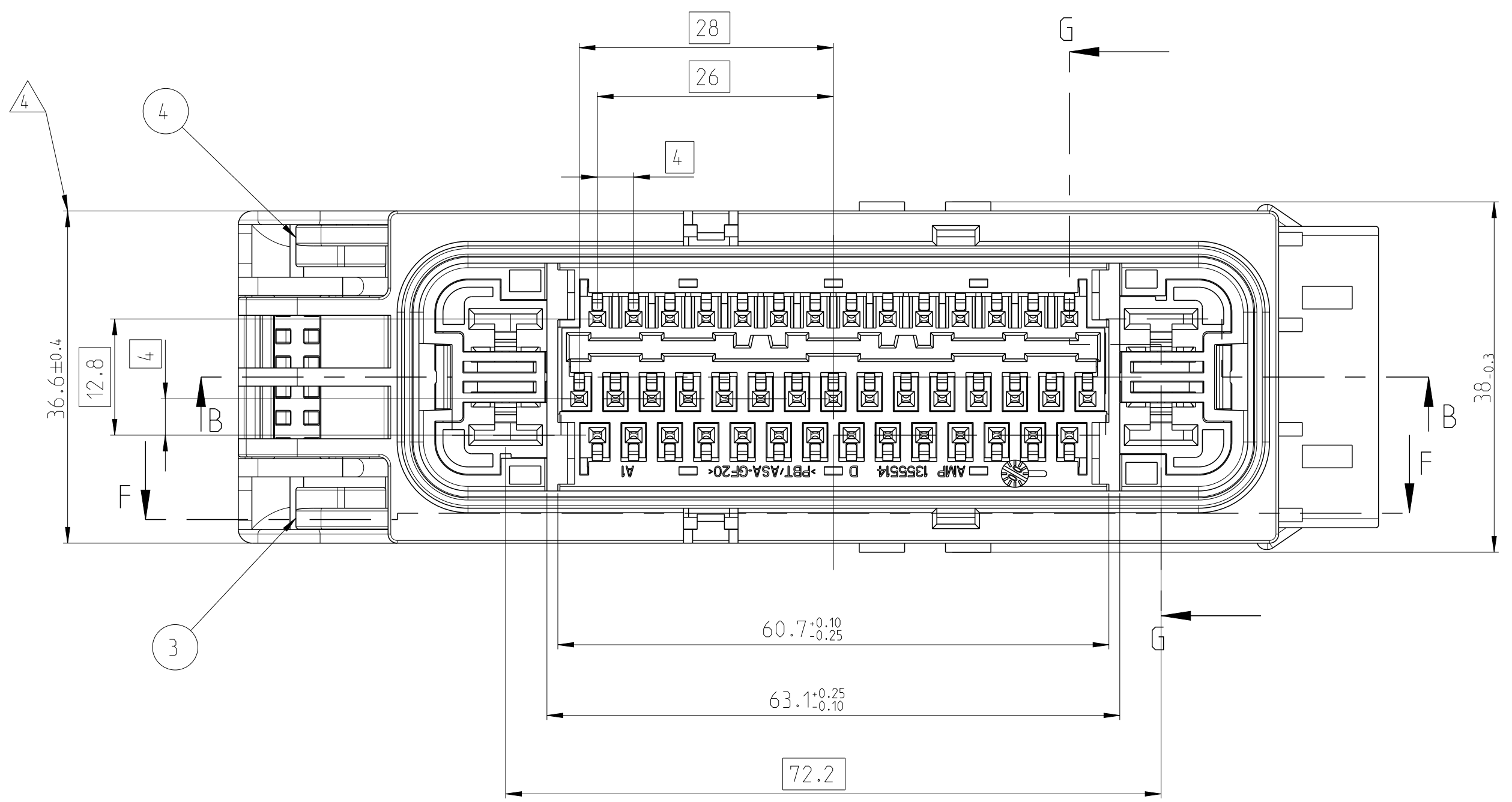
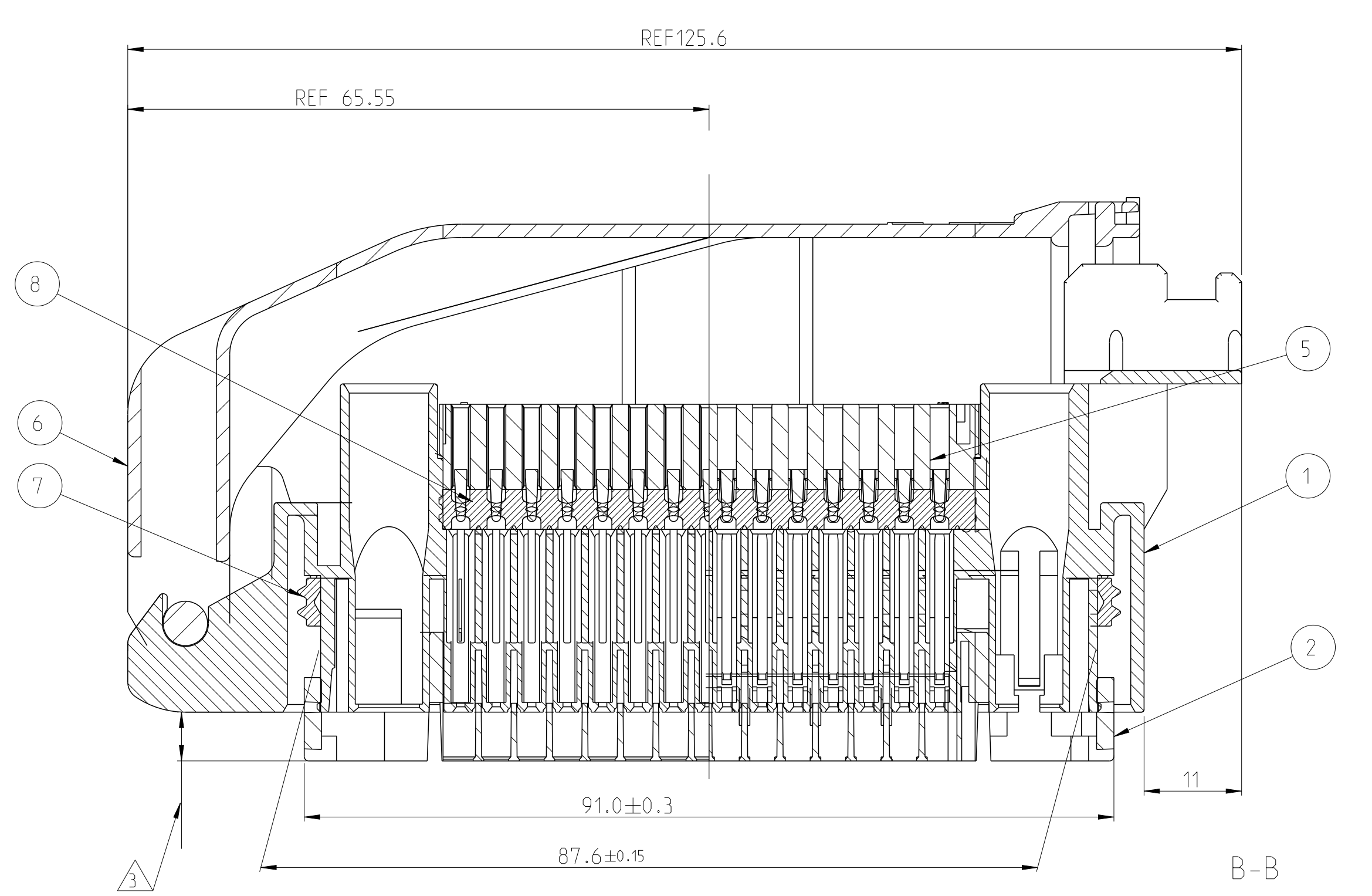
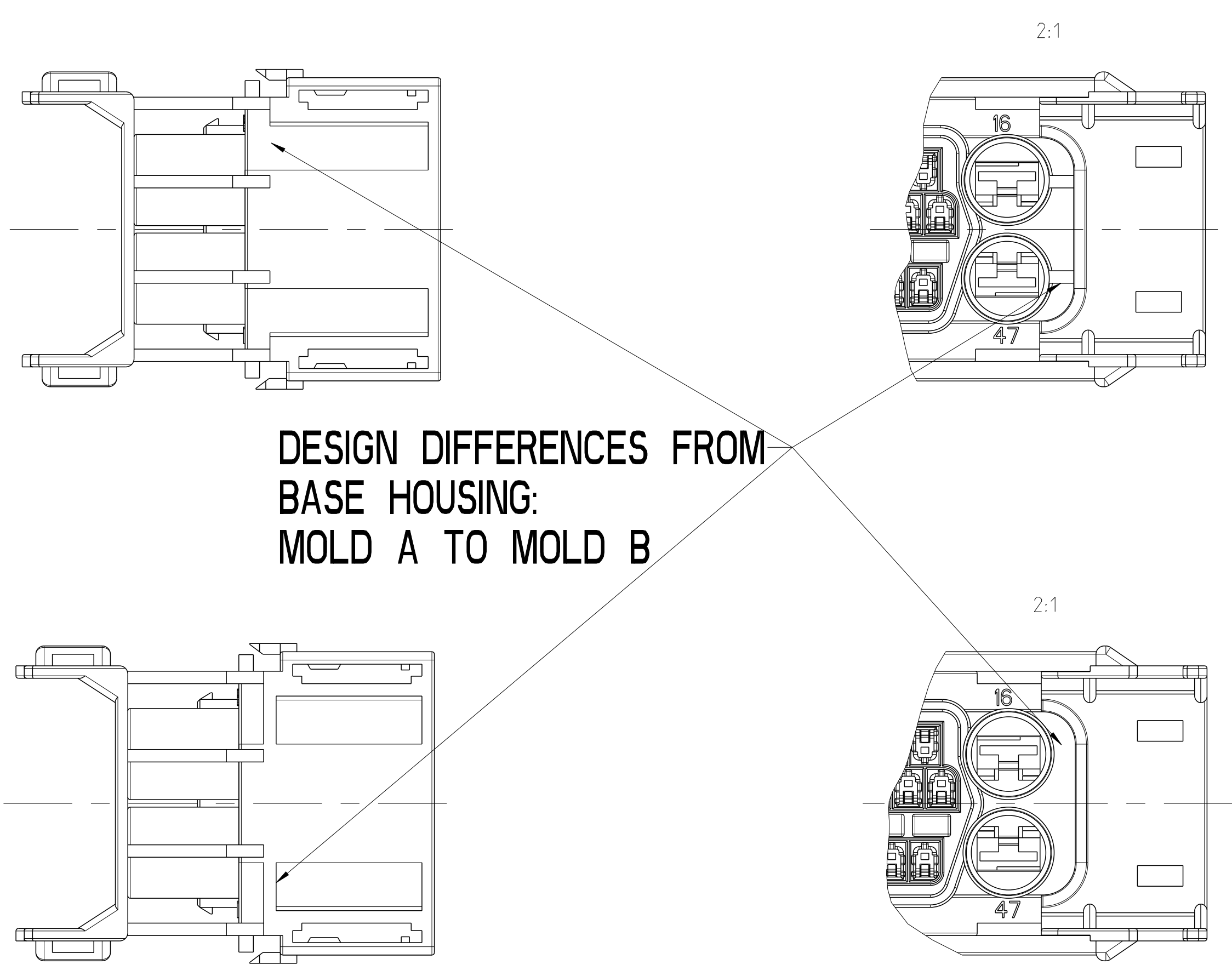
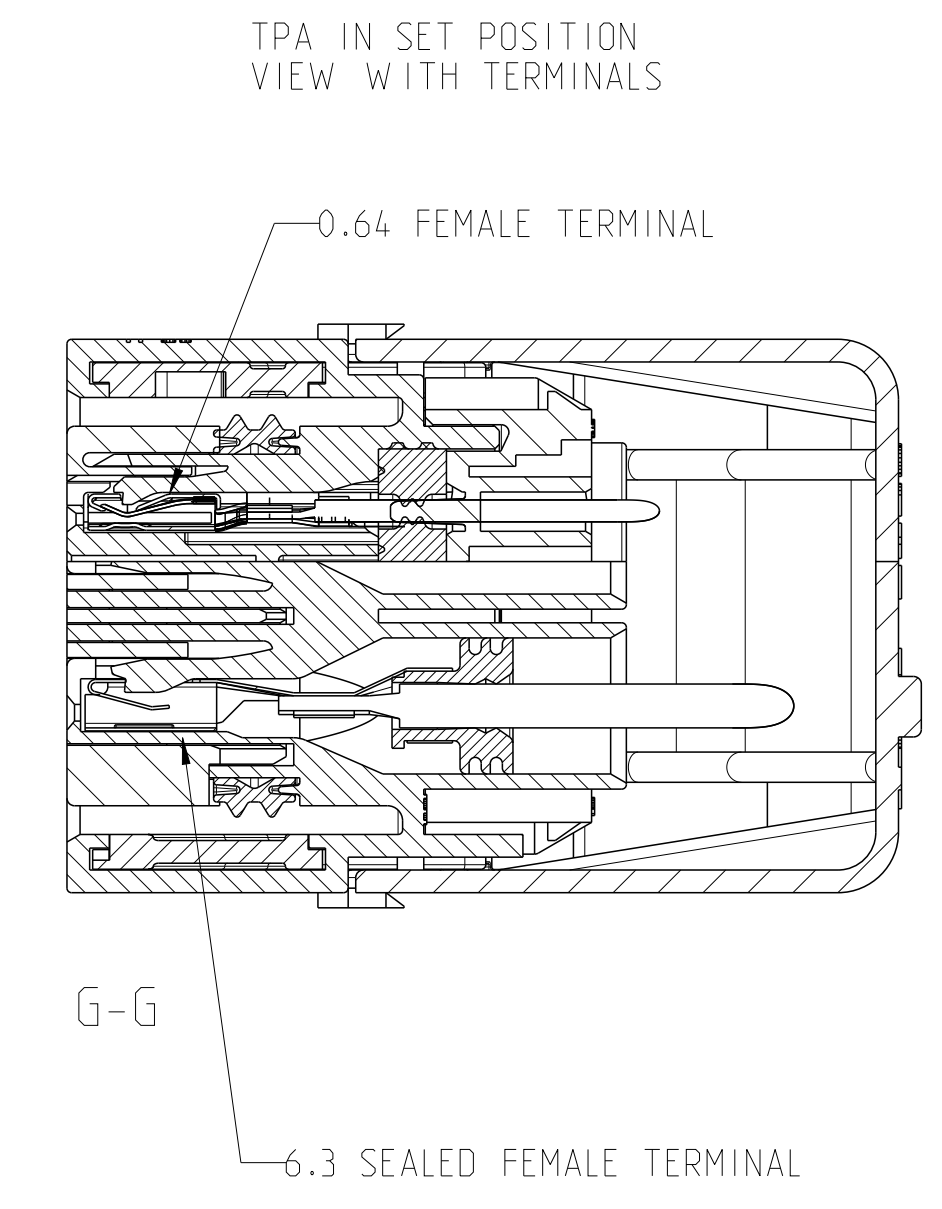
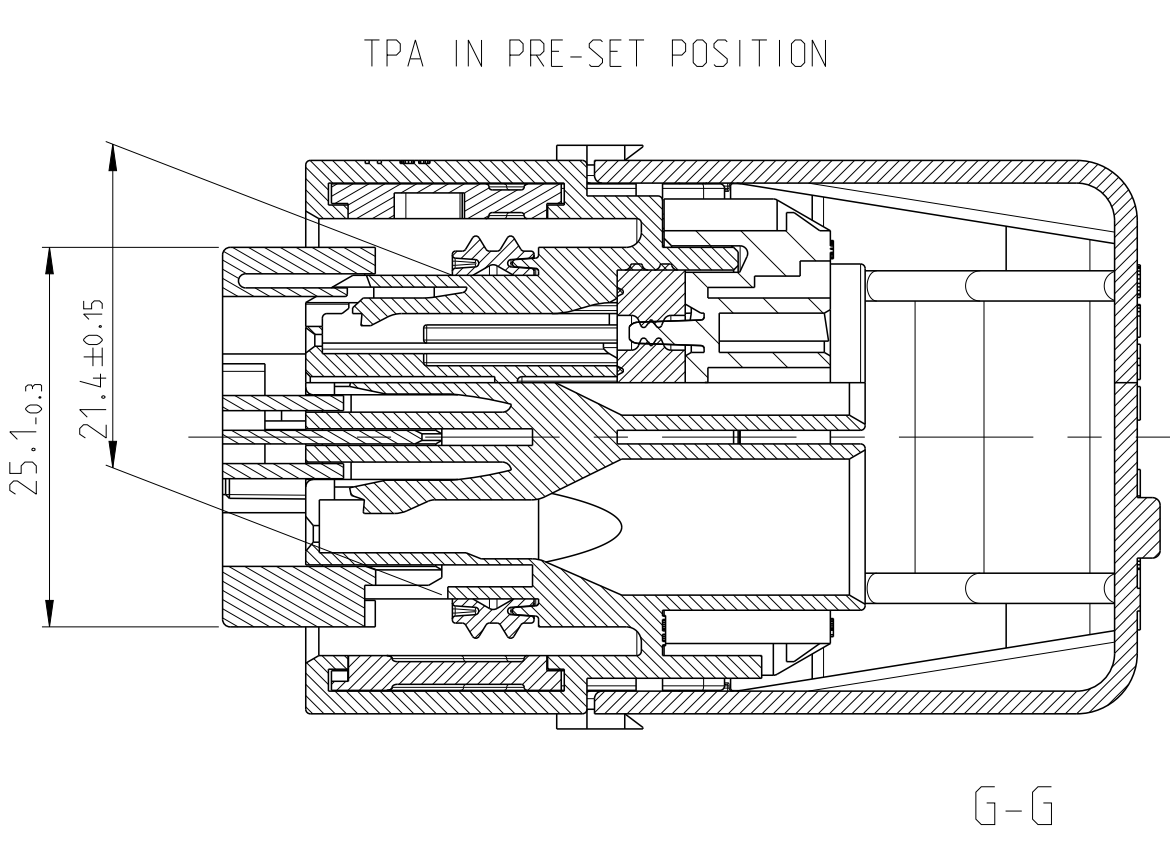
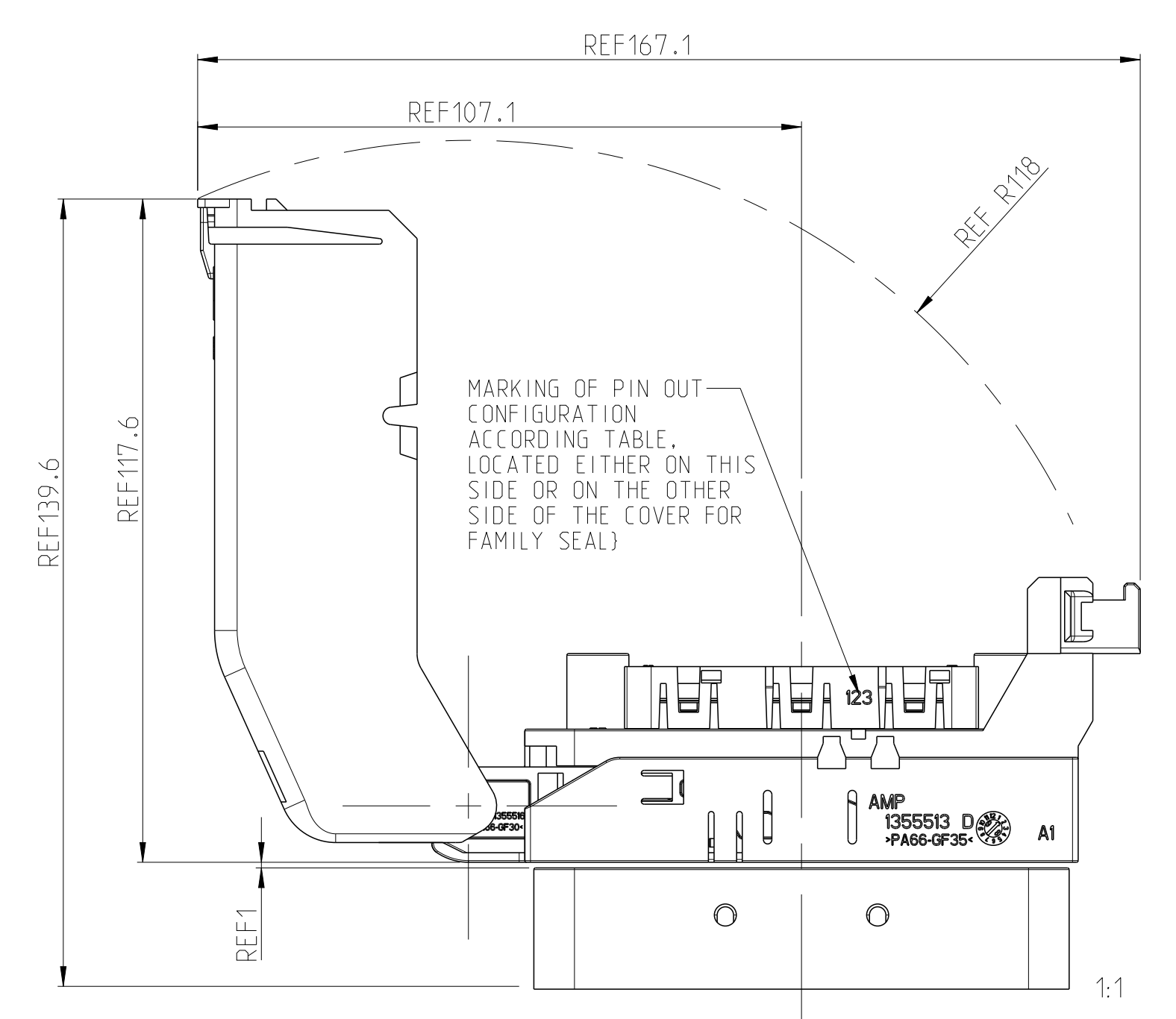

DESIGN DIFFERENCES FROM BASE HOUSING: MOLD A TO MOLD B

3D VIEW

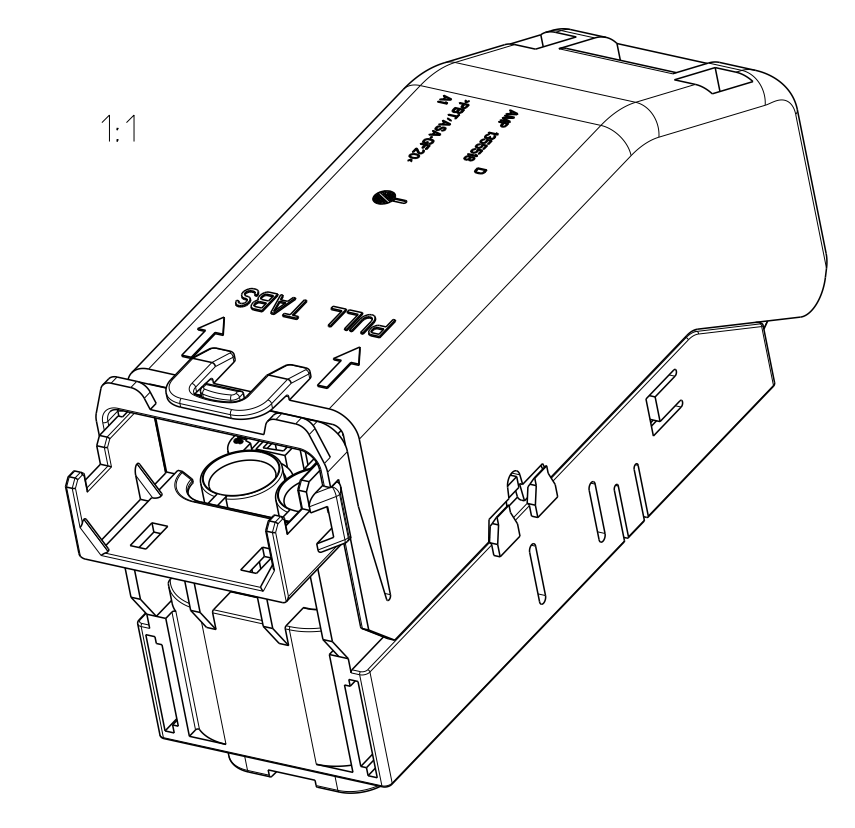

- ⚠ Siehe Tabelle Seite 2 und 3
SEE TABLE SHEET 2 AND 3
- ⚠ SEE PAGE 2
Siehe Blatt 2
- ⚠ SPACER IN PRESET POSITION
Spacer in Vorraststellung
- ⚠ WARPAGE ALLOWED DOWN TO 35.7
Verzug bis 35.7 zulässig
- ⚠ Signal Kontakte sind ausgelegt fuer Kabelgrossen AWG 18-20, Leiterquerschnitt 0.5 - 0.75mm.
Fuer die Dichtigkeit der Steckverbinder ist notwendig, dass der Isolationsdurchmesser 1.4 - 1.9mm befragt.
SIGNAL CONTACTS ARE SUITABLE FOR WIRE SIZE AWG 18-20, CONDUCTOR CROSS SECTION 0.5 - 0.75mm.
FOR THE SEALING OF THE CONNECTOR IT IS NECESSARY TO HAVE A CABLE ISOLATION DIAMETER OF 1.4 - 1.9mm.

CUSTOMER PN	TE- PN	TE- PN	DESCRIPTION	QTY
ZL1T-14A464-AB-XXX	X-2291024-X	X-1355512-X	1x FAMILY SEALING	8
			1x PERIPHERAL SEAL	7
			1x WIRE DRESS COVER	6
			1x COVER FAM.-SEAL	5
			1x RIGHT SLIDE	4
			1x LEFT SLIDE	3
			1x SPACER	2
			1x HOUSING	1
			DESCRIPTION	

THIS DRAWING IS A CONTROLLED DOCUMENT.		DATE: 19MAY2015	BY: JAKLIN	CHK: DMAY99	APPD: DMAY99
DIMENSIONS:	UNITS:	SCALE:	PROJECT SPEC:	APPLICATION SPEC:	WEIGHT:
0 PLC ISO A	1 PLC ISO A	2 PLC ISO A	3 PLC ISO A	4 PLC ISO A	5 PLC ISO A
MATERIAL:		FINISH:	ANGLE:	WEIGHT:	FINISH:
Customer Drawing		SCALE: 2:1	SHEET 1 of 3	REV: N6	



ASSY 47W AY MK25/60
ABS CONNECTOR

REVISIONS table with columns: REV, DATE, APP'D, DESCRIPTION. Includes entry: SEE SHEET 1.

Main table with 32 columns (1-32) and multiple rows. Contains vehicle part numbers, descriptions, and pin configurations. Includes a 'Bemerkung NOTE' section at the bottom with instructions on how to use the numbered fields.

△ PINOUT CONFIGURATIONS SHOWN AS "NOT USED" WERE RAISED FOR THE CONNECTOR FORD/JAGUAR PN 2R81-14A464-KB-XXX LITE PN X-1355628-X) OR VOLVO PN 86456XX (TE PN X-1355956-X)

Customer Drawing information block including dimensions, materials, weights, and drawing specifications. Includes the STE logo and part name: ASSY 47W AY MK25/60 ABS CONNECTOR.

