

SYMBOL DEFINITION		MISSING NUMBERS		DWO STATUS				REVISION HISTORY				AUTH	DR	APVD	APVD		
THE NUMBER INSIDE THE SYMBOL CORRESPONDS TO THE NUMBER ON THE INSPECTION REPORT FOR THIS DRAWING/PART NUMBER	TOTAL NO. OF SYMBOLS ON DRAWING	LAST NO. USED		DATE	STG	REV	N/P	CHO	ZONE								
	8	10		22MY00	R	01	-	-									
				19APOS	R	02	-	-									
										ALL PARTS - REDRAWN TO PD FORMAT: 12048369 MAT'L SPEC WAS R0065444 BLUE, 12129377 MAT'L SPEC WAS R0064366 MD GRV				199739	RH	GMC	JA
										2X (13) TYP WAS 2X 13 TYP				267465	JBD	JAA	NTM

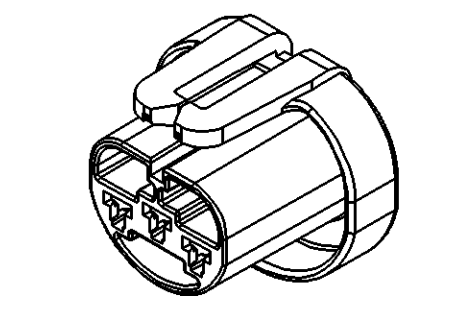
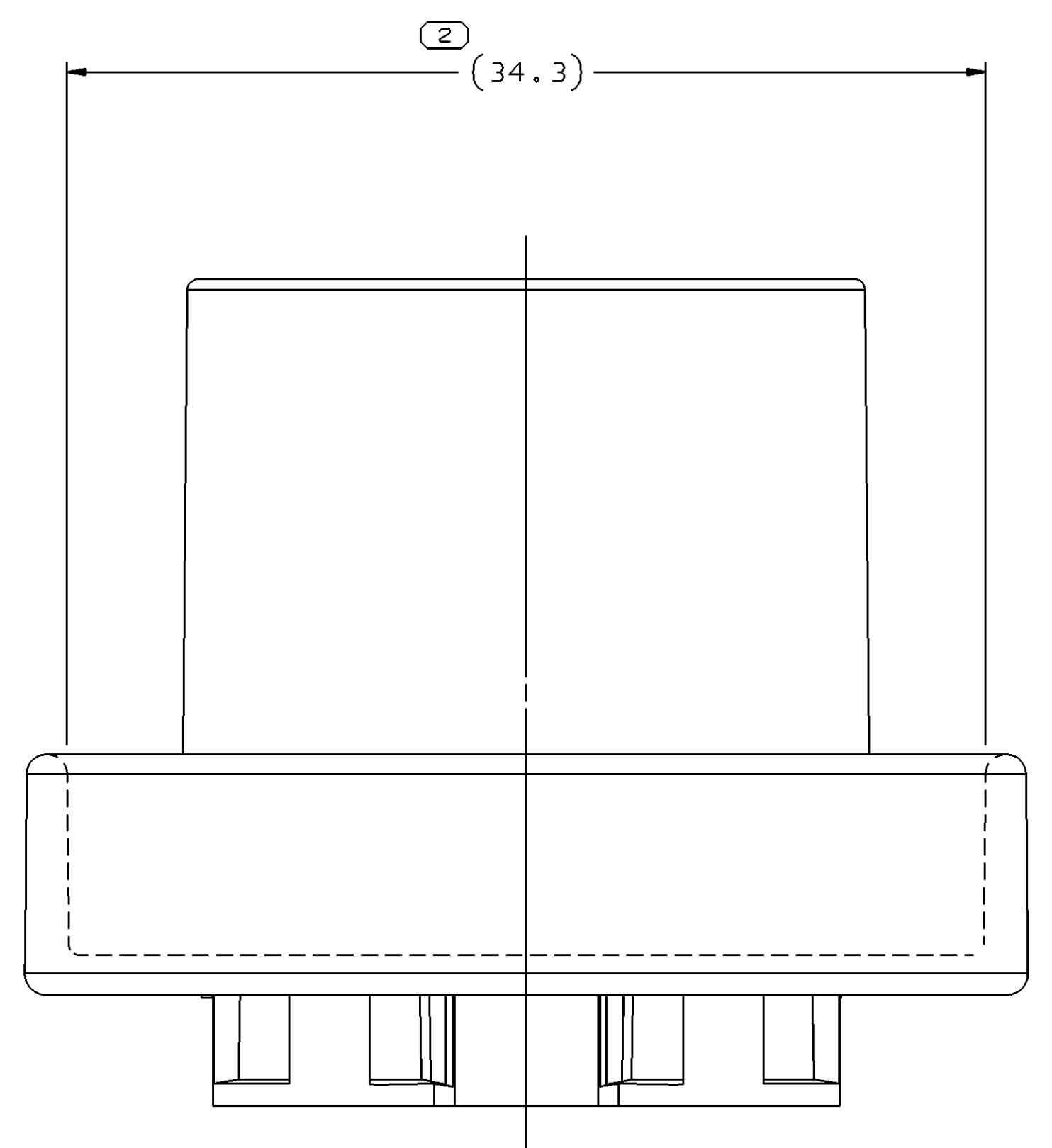
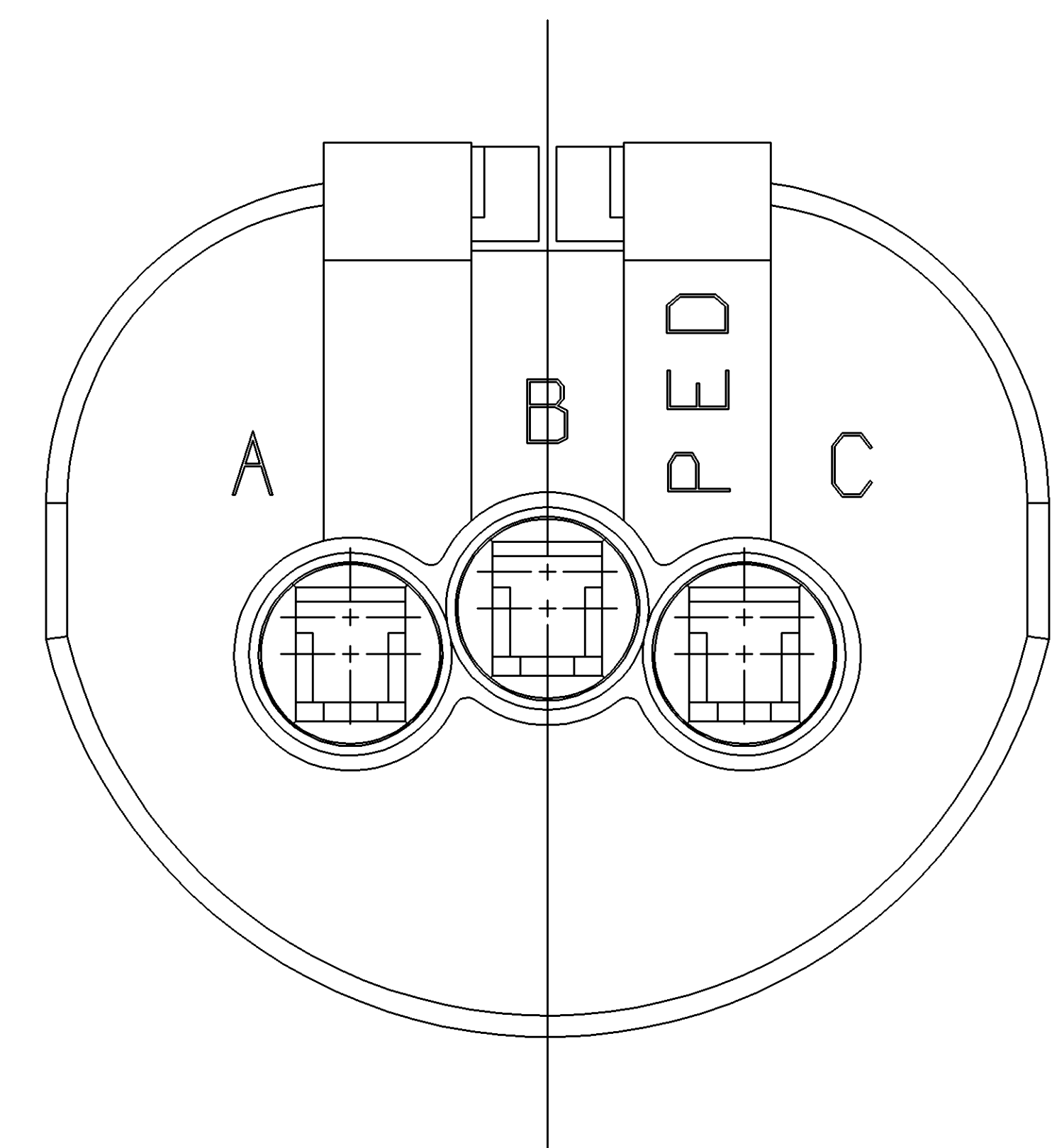
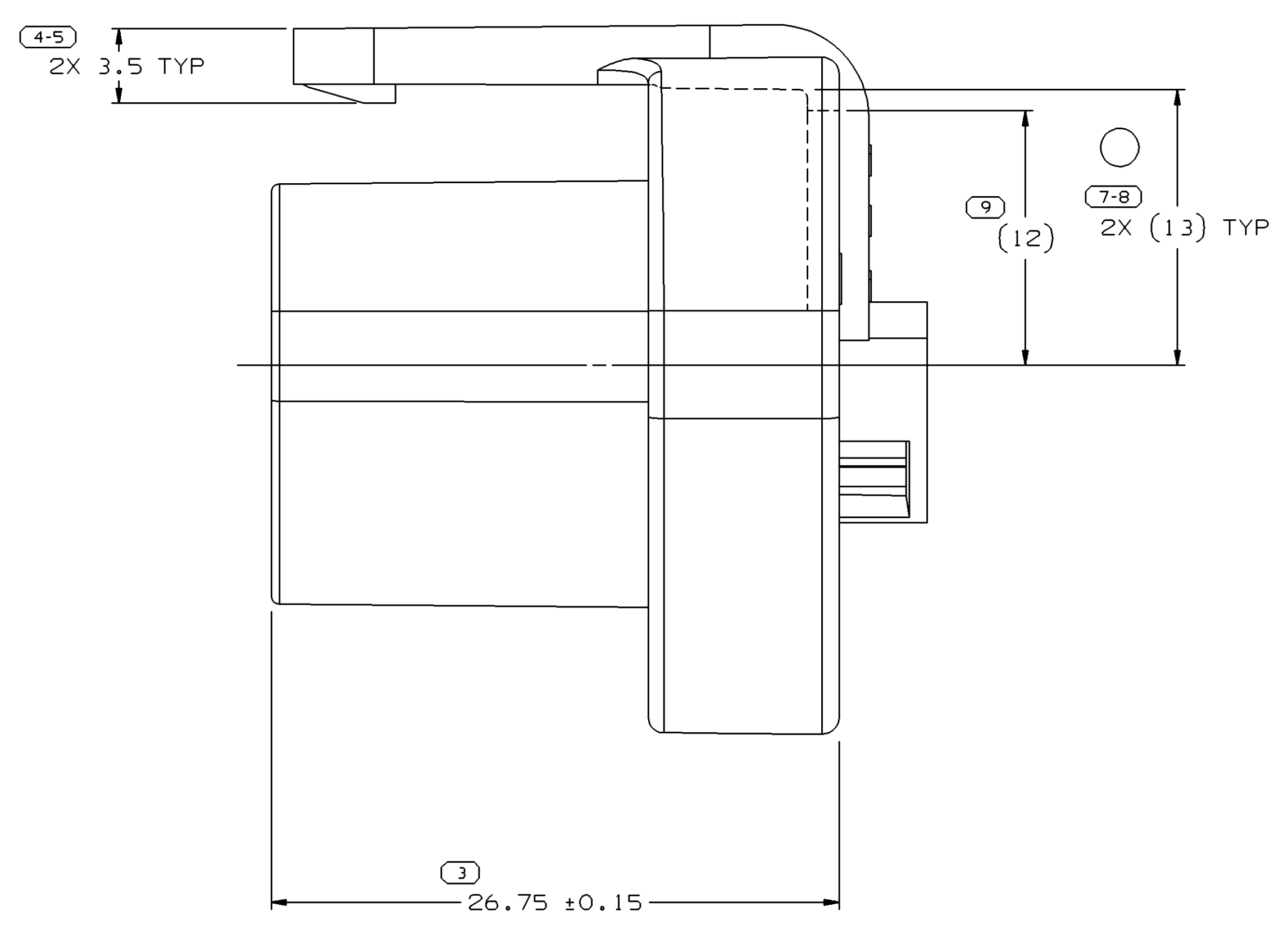
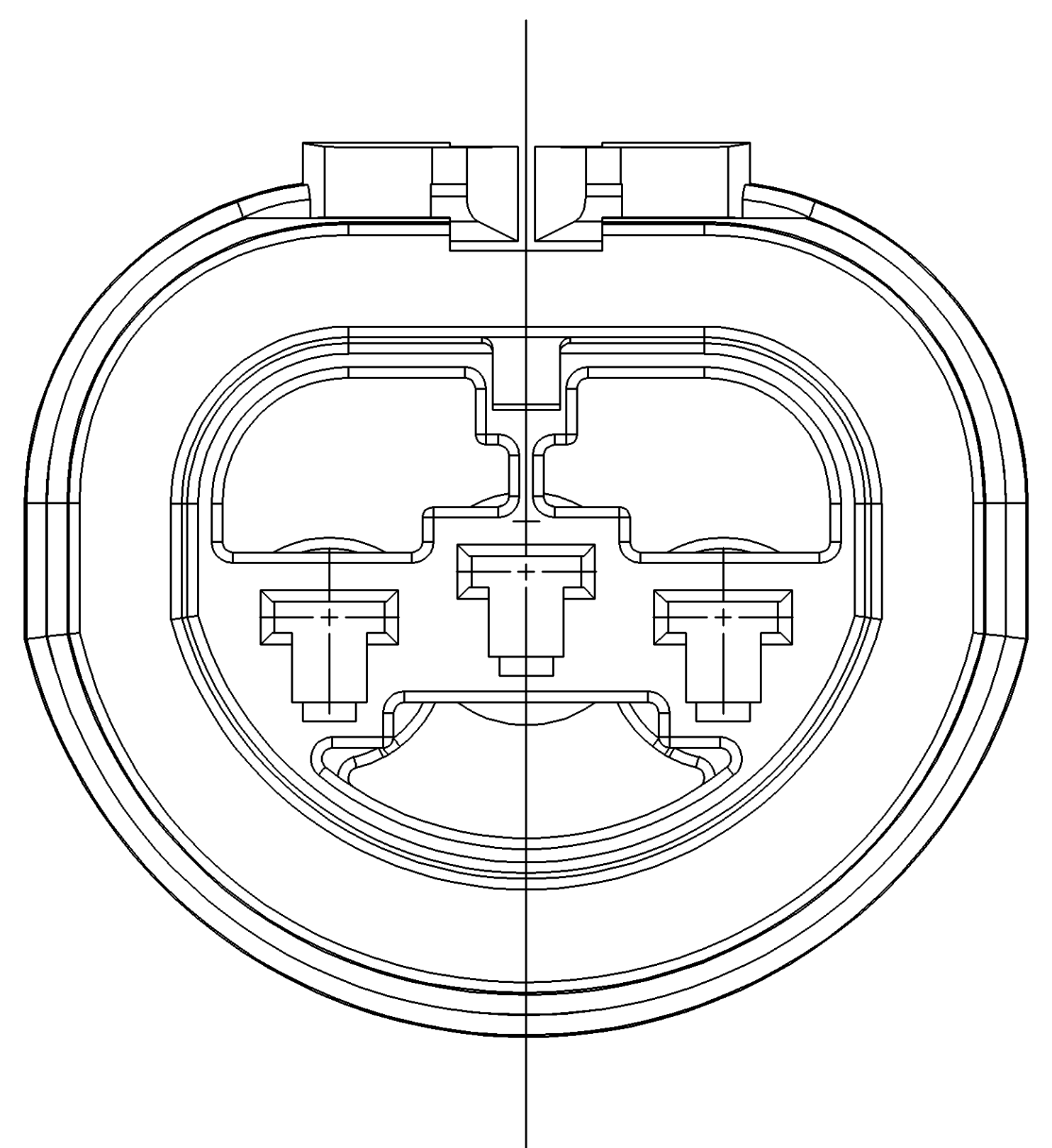
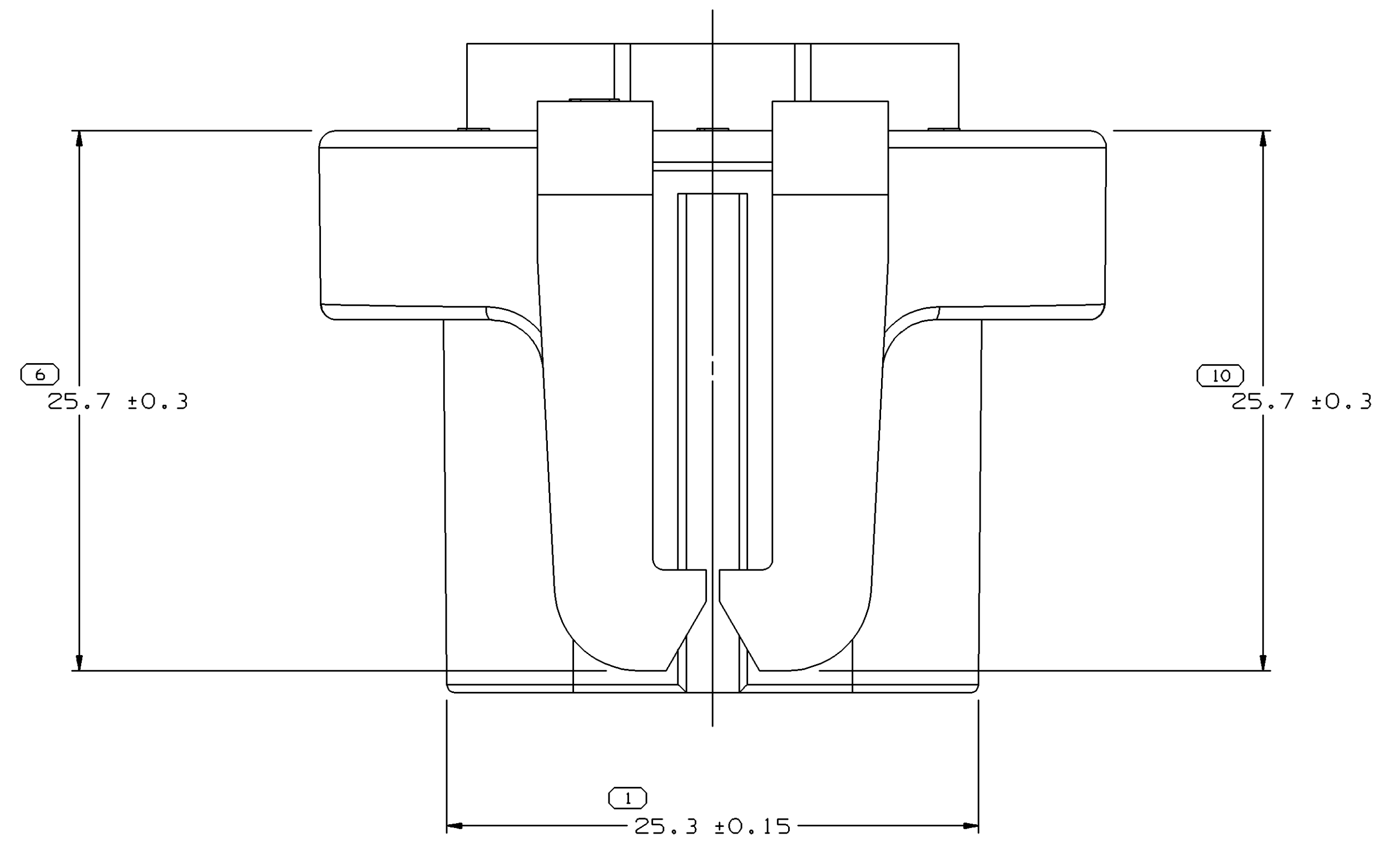

NOTES

- UNLESS OTHERWISE SPECIFIED AND/OR INDICATED:
DIMENSIONS ARE TO FACE OF VIEW SHOWN AND AUTOMATICALLY ROUNDED BY COMPUTER FOR INSPECTION (SEE MATH MODEL FOR PRECISE DIMENSIONS). FOR ALL OTHER DIMENSIONS NOT SHOWN BUT REQUIRED FOR TOOL BUILD, SEE MATH MODEL FOR PRECISE TOOL PATH DATA.
- REFERENCE MATING COMPONENTS OR EQUIVALENT:
GM PART NO. 16504049 HEADLAMP BULB (TRADE NO. 9004)
- THIS PART ACCEPTS THE FOLLOWING COMPONENTS OR EQUIVALENT:
CAVITIES TO ACCEPT 12077411 TERMINAL OR EQUIVALENT.
CABLE SEAL 12010295
GASKET 12048370
TERMINAL POSITION ASSURANCE LOCK 12048371
- SEE CABLE SEAL AND T.P.A. DRAWINGS FOR COMPATIBLE CABLE O.D. RANGE.
- THIS PART IS NOT CONTROLLED FOR AUTOMATIC FEEDING.
- (2.3)X(0.1) DELPHI CORPORATE BRAND TO BE LOCATED ON ANY EXTERIOR SURFACE, PREFERABLY VISIBLE AT FINAL ASSEMBLY. OPTIONAL CONSTRUCTION FOR EXISTING TOOLING MAY BE "PED".

PART NO	REV	N/P	STATUS	MATERIAL SPECIFICATION AND COLOR	VOL CM ³
12129377	02	AA	-	M3592025 PA66 HS IM GRA MD	8.138
12048369	06	AA	-	M3592008 PA66 HS IM BLU	8.138

DIMENSIONAL RANGE (MM)	CHART	ET
FROM > 0	> 20	> 30
TO 20	30	70
	100	150
	200	250
	300	400
TOLERANCE UNLESS OTHERWISE SPECIFIED		
	±0.15	±0.3
	±0.4	±0.6
	±0.8	±1
	±1.2	
ANGULAR TOLERANCE ±2°		

DWO TYPE		PART DRAWING	
STYLE		DISTR CODE	D
VOLUME (CM ³)	SEE CHART		
UNLESS OTHERWISE SPECIFIED			
PERFECT FORM REQUIRED FOR FEATURES OF SIZE AT MMC. THE POSITION TOLERANCES AND RELATED DATUMS APPLY AT CONDITION OF SIZE INDICATED IN FEATURE CONTROL FRAME. ALL OTHER GEOMETRIC TOLERANCES AND RELATED DATUMS APPLY OFF. SEPARATE TRUE POSITION CALCULATIONS MAY BE OBTAINED SEPARATELY, REGARDLESS OF DATUM REFERENCE.			
ALL DIMENSIONS ARE IN MILLIMETERS			
REFERENCE		THIRD ANGLE PROJECTION	DO NOT SCALE
		USE MATH DATA	UNSPRINGS

DELPHI
DELPHI PACKARD ELECTRIC SYSTEMS
WARREN, OH

DR	DATE
APVD1 R. HERMOSILLO	22MY00
APVD2 G. MACIAS	12JN00
APVD3 J. ALVAREZ	16JN00
APVD4	
APVD5	

SUBSTANCES OF CONCERN AND RECYCLED CONTENT PER DELPHI 10949001

MATERIAL SEC CHART

DRAWING NAME
TAXI CONN 2 F M/P 280 SLD

DRAWING NUMBER
12052373

SIZE	SCALE	FRAME NO	SHEET NO	STG	REV	N/P
A0	5:1	1 OF 1	3 OF 3	R	02	-