

DO NOT SCALE

DIMENSIONS IN mm

METRIC

THIRD ANGLE PROJECTION

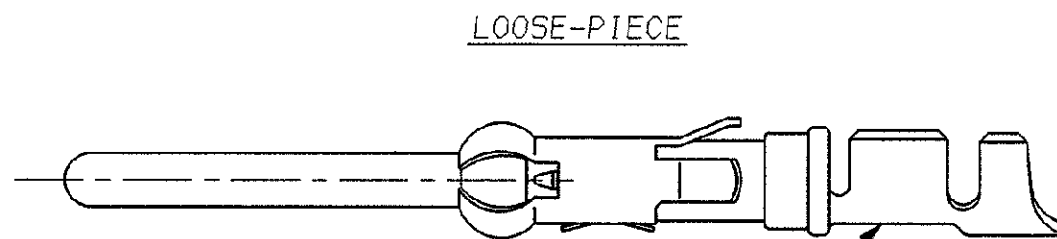
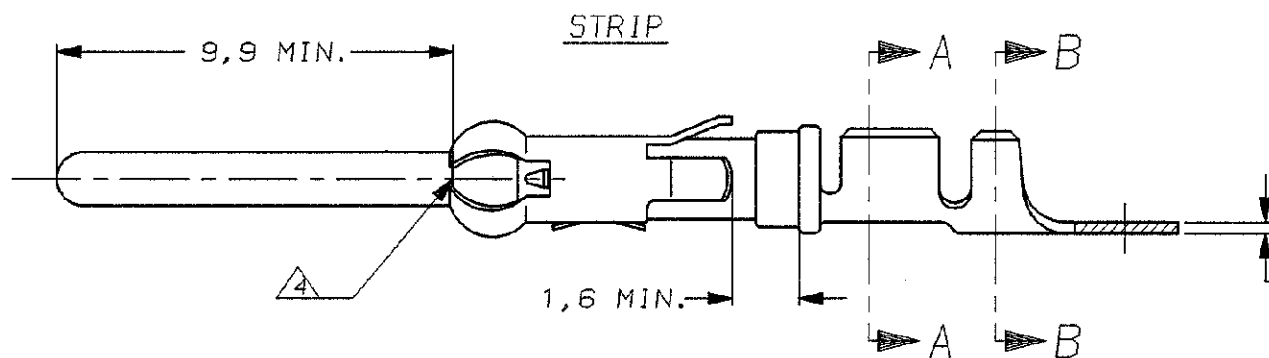
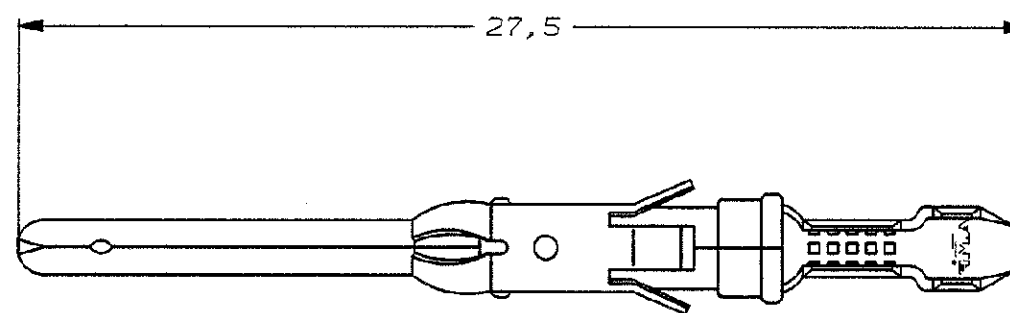
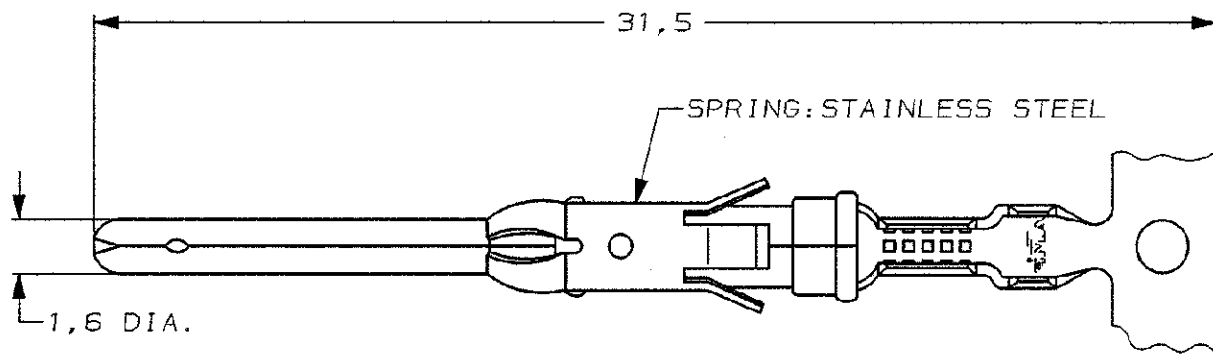
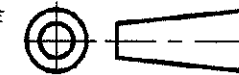

COLOR CODE: BLUE

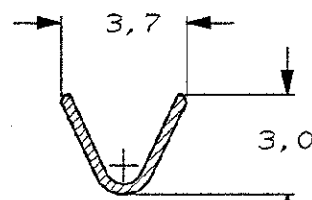
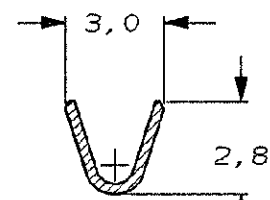

SECTION A-A

SECTION B-B

WIRE RANGE : 0,75-1,50 mm<sup>2</sup> (18-16 AWG)  
INSUL. RANGE : 2,0-2,5 mm (.080-.100)

NOTES :

- 1 U.L. RECONIZED UNDER FILE E28476 VOL.VI SEC.I .
- 2 FOR CRIMPDETAILS SEE AMP-SPEC. 114-19.000 .
- 3 MEETS PRODUCT SPECIFICATION 108-10042.
- 4 0,40 MAX. GAP BETWEEN SPRING-NOSE AND CONTACT BODY.
- 5 SPECIAL REEL WITH 200 PCS FOR REEL-FED HANDTOOL.

| NOTES | MATERIAL                     | THICKNESS             | AREA                                 |
|-------|------------------------------|-----------------------|--------------------------------------|
| 20    | TIN                          | 2,0 μm                | ALL OVER                             |
| 21    | NICKEL<br>GOLD<br>TIN/LEAD   | 0,8 μm                | ALL OVER<br>CONTACT AREA<br>BARREL   |
| 22    | NICKEL<br>GOLD<br>GOLD       | 0,8 μm                | ALL OVER<br>CONTACT AREA<br>ALL OVER |
| 23    | NICKEL<br>GOLD<br>GOLD       | 1,2 μm                | ALL OVER<br>CONTACT AREA<br>ALL OVER |
| 24    | NICKEL<br>SILVER<br>TIN/LEAD | 2,5 μm                | ALL OVER<br>CONTACT AREA<br>BARREL   |
| 25    | SILVER<br>NICKEL             | 1,5-2,5 μm<br>0,76 μm | ALL OVER<br>ALL OVER                 |
| 26    | SILVER                       | 2,5 μm                | ALL OVER                             |
| 27    | NICKEL                       | 1,27 μm               | ALL OVER                             |
| 28    | TIN/LEAD                     | 1,27 μm               | ALL OVER                             |
| 29    | LUBRICATED                   |                       |                                      |

| DIRECTION OFF TOP OF REEL             |   |
|---------------------------------------|---|
| AMPOMATOR + MINI-APPL.<br>107-3-FIG.1 | A |
| 107-3-FIG.2                           | B |
| 107-3-FIG.4                           | C |

| PARTNUMBER | DIRECTION OF REEL | LOOSE-PIECE | MATERIAL   | PLATING    |
|------------|-------------------|-------------|------------|------------|
| 5-163081-3 | A                 |             | BRASS      | ECON. GOLD |
| 5-163081-2 | A                 |             | BRASS      | SEL. GOLD  |
| 5-163081-1 | A                 |             | BRASS      | EL. TIN    |
| 1-163081-8 | A                 | 1-163082-8  | BRASS      | TIN/LEAD   |
| 1-163081-7 | A                 |             | BRASS      | SILVER     |
| 1-163081-6 | B                 | 1-163082-6  | BRASS      | SILVER     |
| 1-163081-5 | A                 |             | PH. BRONZE | PRE-TIN    |
| 1-163081-4 | B                 |             | PH. BRONZE | PRE-TIN    |
| 1-163081-3 | A                 |             | BRASS      | PRE-TIN    |
| 1-163081-2 | B                 |             | BRASS      | PRE-TIN    |
| 1-163081-1 | A                 | 1-163082-0  | BRASS      | ECON. GOLD |
| 1-163081-0 | B                 |             | BRASS      | ECON. GOLD |
| 163081-9   | A                 | 1-163082-1  | BRASS      | EL. TIN    |
| 163081-8   | A                 |             | BRASS      | EL. TIN    |
| 163081-7   | A                 |             | BRASS      | SEL. GOLD  |
| 163081-2   | B                 | 163082-2    | BRASS      | SEL. GOLD  |
| 163081-1   | B                 | 163082-1    | BRASS      | EL. TIN    |

| AW              | W    | V   | U        | T | LTR. | DR. | CHK. | APP. | DATE |
|-----------------|------|-----|----------|---|------|-----|------|------|------|
| EBD0-0335-04    | JMS  | FWK | 02-08-04 |   |      |     |      |      |      |
| EH-1347-96      | JvL  | RV  | 21-11-96 |   |      |     |      |      |      |
| EH-0302-94      | JvL  | MvD | 03-05-94 |   |      |     |      |      |      |
| ECN H-9813      | JvdH | RD  | 18-05-92 |   |      |     |      |      |      |
| ECN H-9192      | MvD  | RD  | 09-10-91 |   |      |     |      |      |      |
| REVISION RECORD |      |     |          |   |      |     |      |      |      |

**CUSTOMER DRAWING** FOR REFERENCE ONLY  
WILL NOT BE UPDATED

© COPYRIGHT 19- BY AMP HOLLAND B.V.  
ALL INTERNATIONAL RIGHTS RESERVED. AMP PRODUCTS MAY BE COVERED BY U.S. AND FOREIGN AND/OR PATENTS PENDING.  
THIS DRAWING IS UNPUBLISHED  
RELEASED FOR PUBLICATION

**AMP** | AMP HOLLAND B.V.  
's-Hertogenbosch,  
The Netherlands.

NAME

**PIN TYPE III CONTACT**  
SIZE 16

|       |   |       |   |       |   |          |        |           |    |       |        |    |
|-------|---|-------|---|-------|---|----------|--------|-----------|----|-------|--------|----|
| DR.:  | - | CHK.: | - | APP.: | - | DWG. No. | 163081 | REV. LTR. | AW | SHEET | 1 OF 1 | A3 |
| DATE: | - | DATE: | - | DATE: | - |          |        |           |    |       |        |    |