

USABLE WITH TAB 0.8mm AND TAB 0.6mm THICKNESS
 Verwendbar mit Flachstecker 0.8mm und 0.6mm Dicke

CONTACTS FOR FLR-CABLE
 Kontakte fuer FLR-Leitung

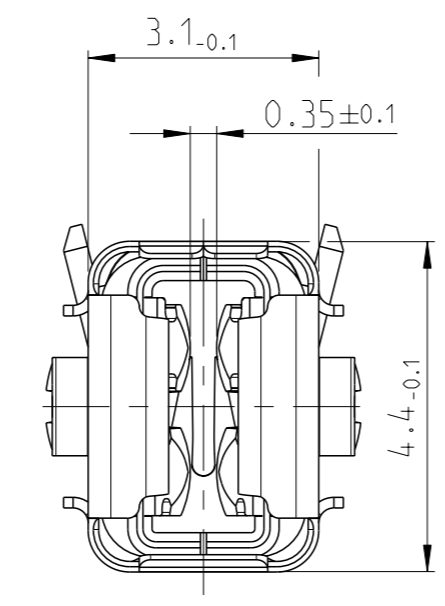

TYPE B1

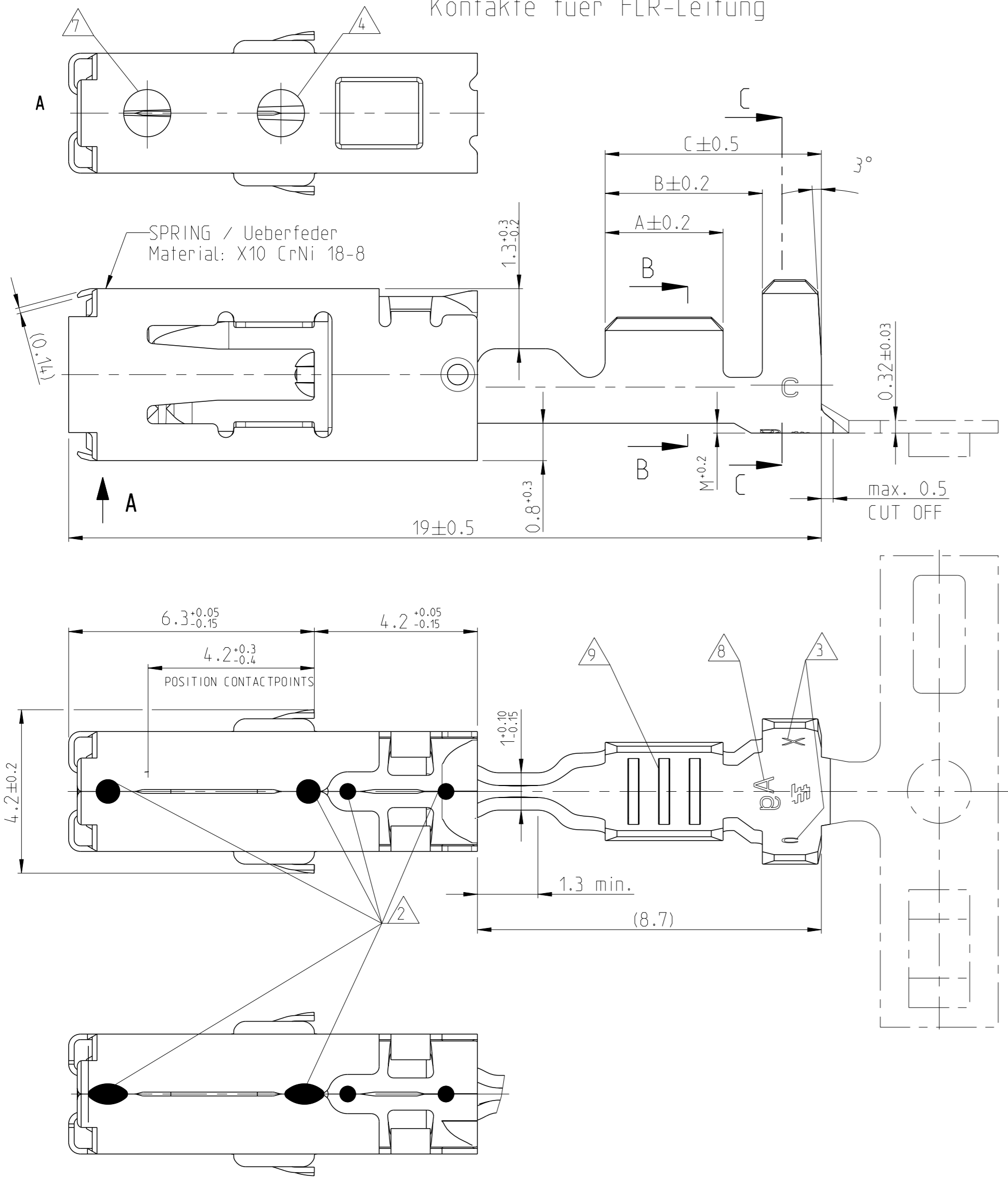
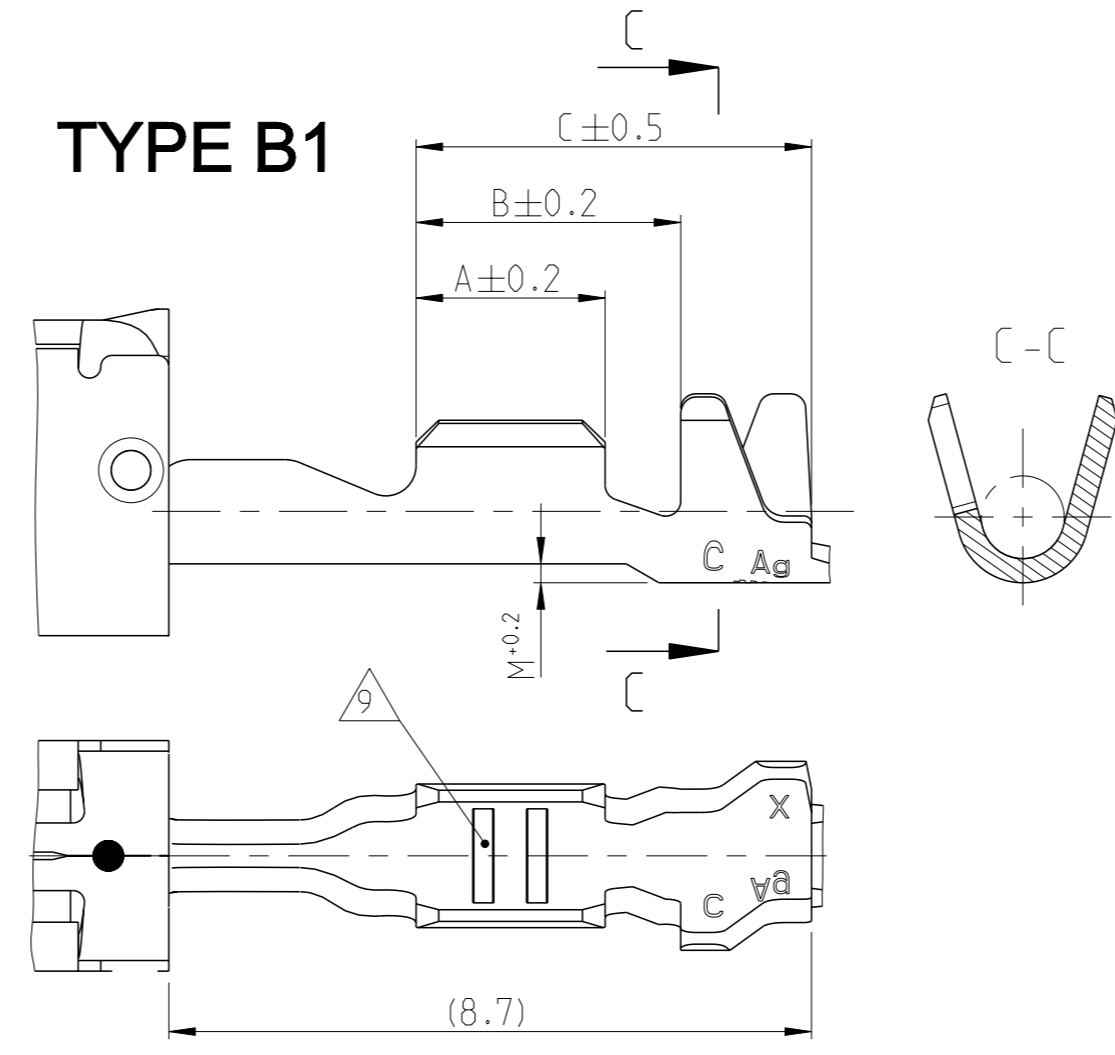

TYPE C1

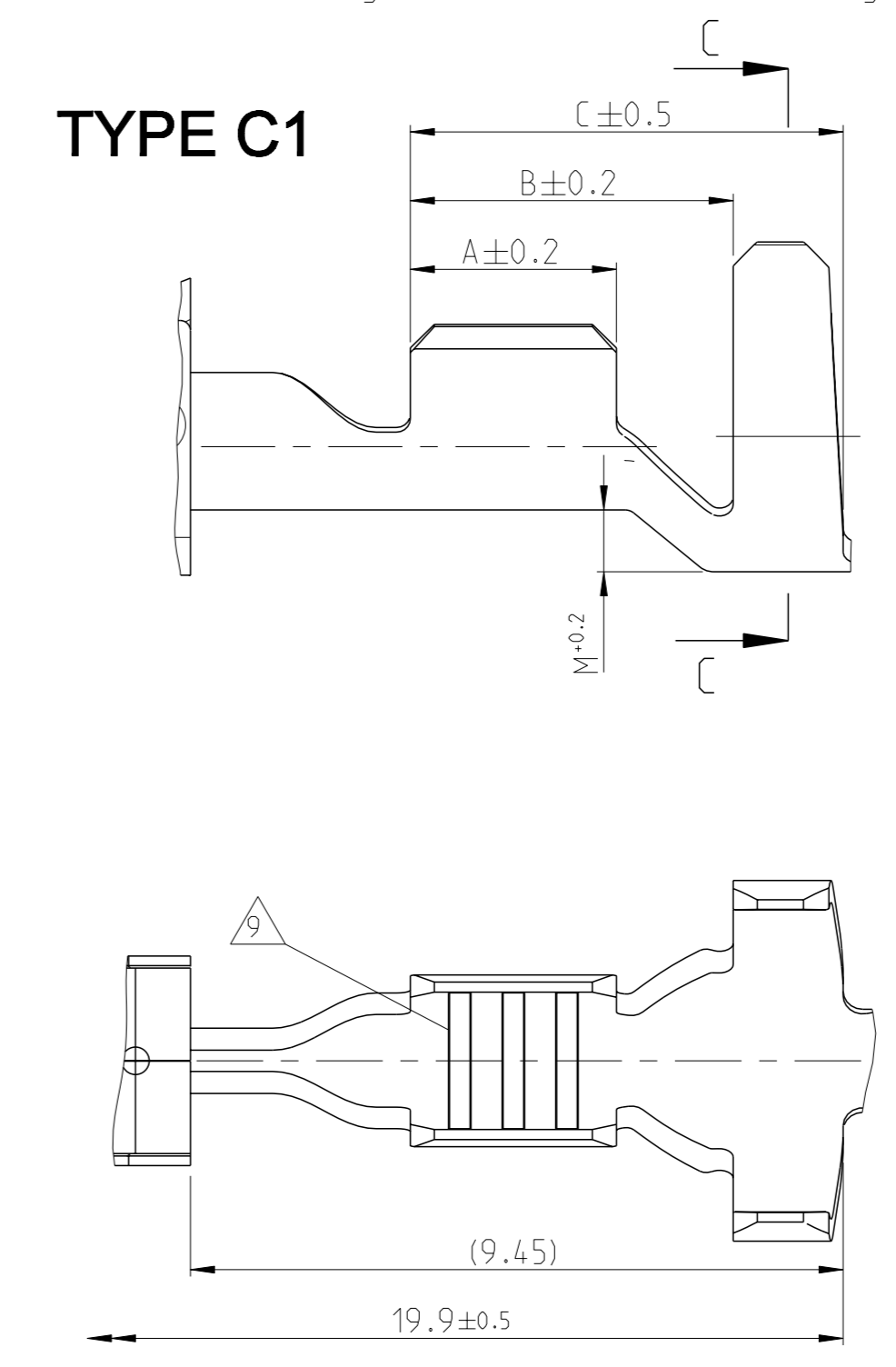

TYPE C2 A16

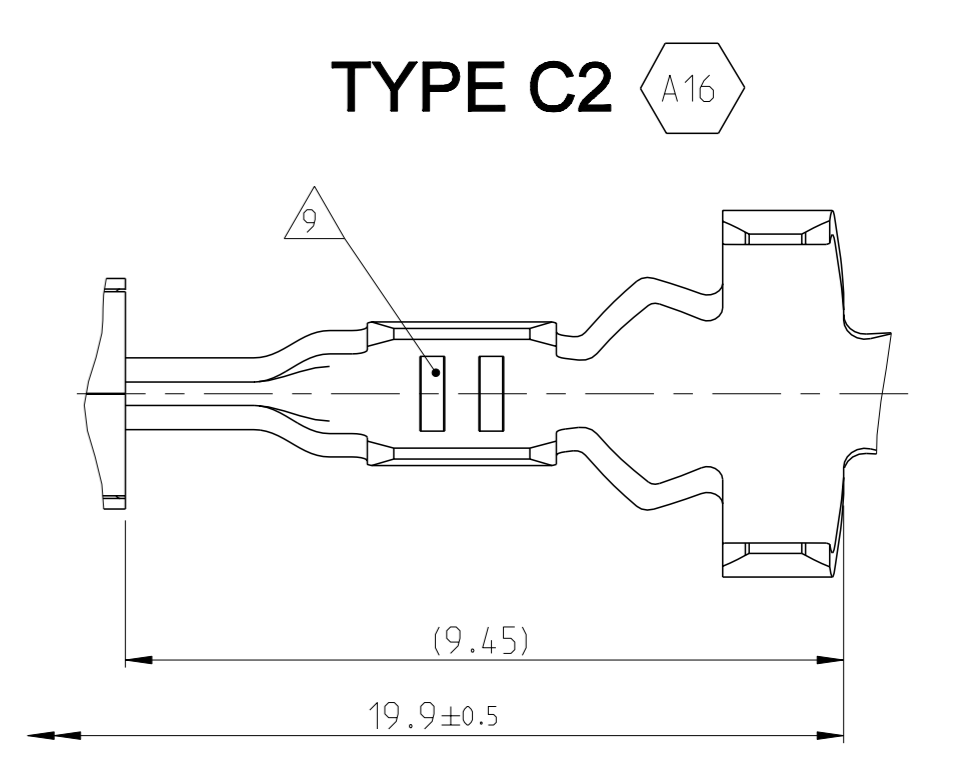

TYPE A

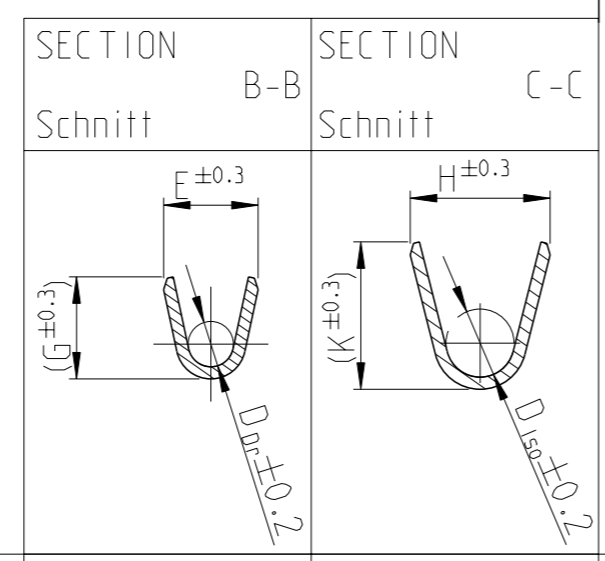

TYPE B2

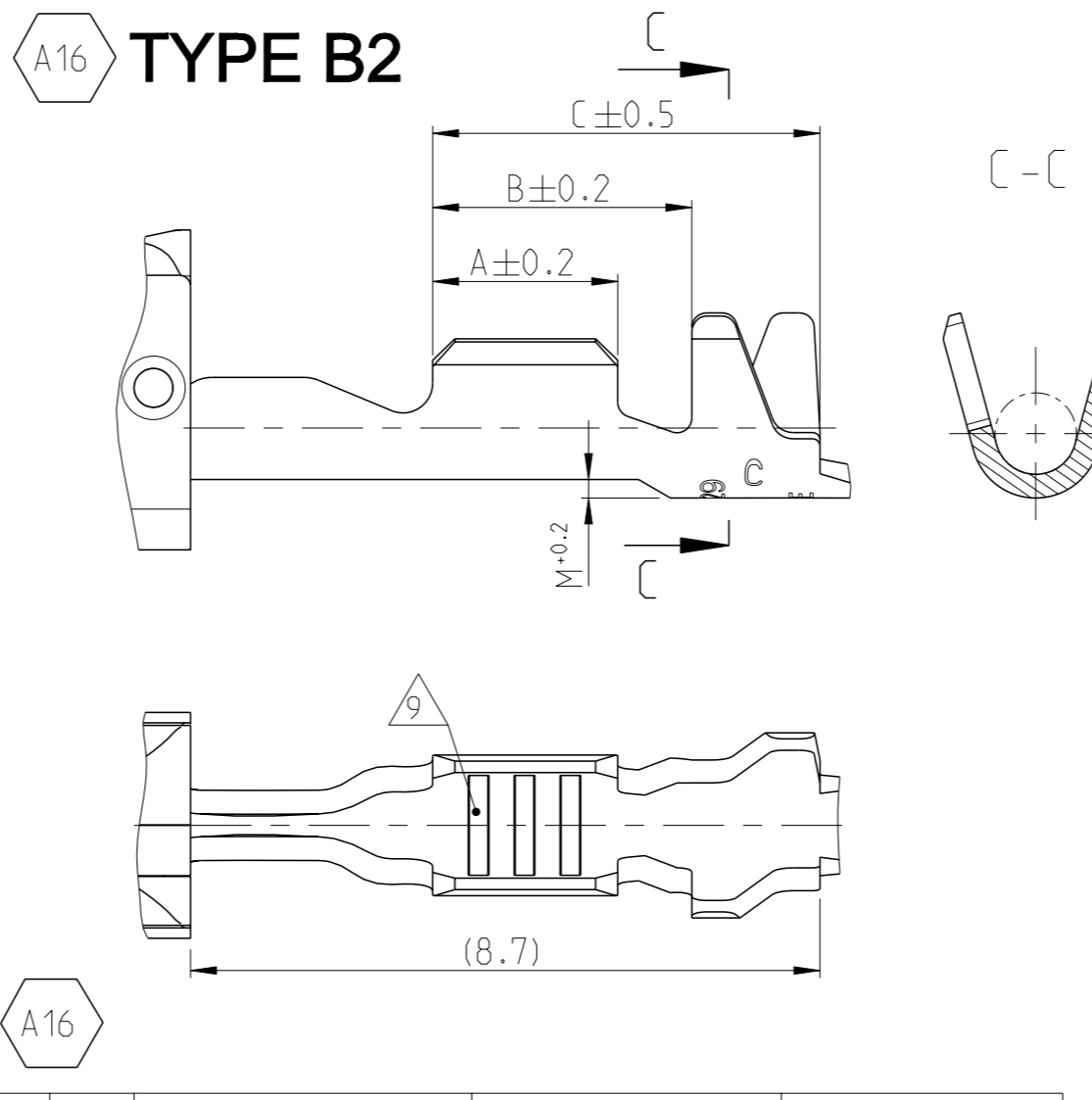

SINGLE WIRE SEALING SYSTEM

ORDER NO. Bestell-Nr.	INSULATION DIA Isolations Ø	COLOUR Farbe
963292-1	2.7...3.0	YELLOW gelb
963293-1	2.0...2.7	REDBROWN rotbraun
963294-1	1.2...2.1	BLUE blau

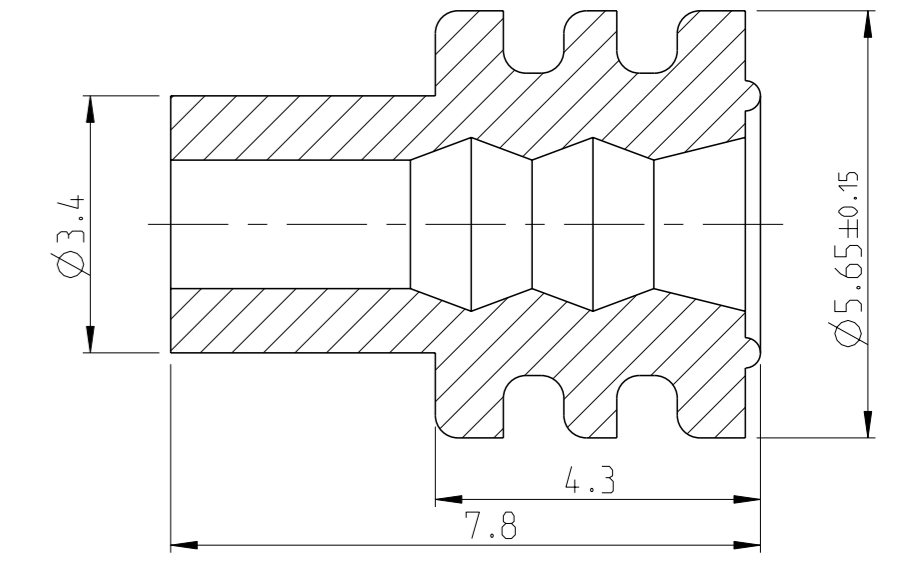

ORDER NO. Bestell-Nr.	REV.	WIRE RANGE Drahtgroessen- bereich (mm 2)	INSULATION DIA Isolations Ø (mm)	MATERIAL Werkstoff	PLATING Ueberzug	LENGTH Laenge	WIRE CRIMP Drahtcrimp	INSUL. CRIMP Isol.-Crimp	CRIMP DATA AND CRIMP TOOL	EXTRACTION TOOL Ausdruckwerkzeug	CRIMP DATA AND CRIMP TOOL
0-1241396-4	C	>1.0-2.5	2.2-3.0	CuNiSi	SILVERPLATED versilbert	A = 3.5 B = 5.2 C = 6.8	E = 3.6 G = 3.8 D _{Dr} = 1.8	H = 5.45 K = (4.8) D _{iso} = 3.5 M = 0.85	C1	HANDCRIMP TOOL Handcrimpwerkzeug 539635-1	539969-1
0-1241396-3	C			CuNiSi	PRESILVER vorversilbert						
0-1241396-2	C			CuNiSi	TINPLATED vorverzinkt						
0-1241396-1	C	0.5-1.0	1.4-2.7	CuNiSi	PRESILVER vorversilbert	A = 3.0 B = 4.7 C = 6.3	E = 2.5 G = 2.7 D _{Dr} = 1.2	H = 5.25 K = (4.8) D _{iso} = 3.3 M = 0.75	C1	INSERT / Matrize 539952-2	
0-1241394-3	C			CuNiSi	TINPLATED vorverzinkt						
0-1241394-2	C			CuNiSi	PRESILVER vorversilbert						
0-1241392-3	C	0.2-0.35	1.1-1.4	CuNiSi	PRESILVER vorversilbert	A = 2.5 B = 4.7 C = 6.3	E = 1.9 G = 1.9 D _{Dr} = 0.75	H = 4.85 K = (4.4) D _{iso} = 3.2 M = 0.7	C1	HANDCRIMP TOOL 539635-1	
0-1241392-2	C			CuNiSi	TINPLATED vorverzinkt						
0-1241392-1	C			CuNiSi	PRESILVER vorversilbert						
0-1564984-3	C	0.2-0.35	1.1-1.4	CuNiSi	PRESILVER vorversilbert	A = 3.3 B = 4.3 C = 5.8	E = 2.4 G = 2.3 D _{Dr} = 1.0	H = 4.7 K = (4.9) D _{iso} = 2.6 M = 0.4	C1	INSERT 4-1579016-1	
0-1564984-2	C			CuNiSi	TINPLATED vorverzinkt						
0-1564984-1	C			CuNiSi	PRESILVER vorversilbert						
0-1241390-3	C	>1.0-2.5	2.2-3.0	CuNiSi	PRESILVER vorversilbert	A = 3.0 B = 4.0 C = 5.5	E = 2.5 G = 2.7 D _{Dr} = 1.2	H = 3.7 K = (3.9) D _{iso} = 1.8 M = 0.2	TYPE A	HANDCRIMP TOOL Handcrimpwerkzeug 539635-1	
0-1241390-2	C			CuNiSi	TINPLATED vorverzinkt						
0-1241390-1	C			CuNiSi	PRESILVER vorversilbert						
0-1241388-3	C	0.5-1.0	1.4-2.1	CuNiSi	PRESILVER vorversilbert	A = 2.5 B = 3.5 C = 5.2	E = 1.9 G = 1.9 D _{Dr} = 0.75	H = 2.5 K = (2.5) D _{iso} = 1.1 M = 0.2	TYPE B1	INSERT / Matrize 539951-2	
0-1241388-2	C			CuNiSi	TINPLATED vorverzinkt						
0-1241388-1	C			CuNiSi	PRESILVER vorversilbert						
0-1241386-3	C	0.2-0.35	1.1-1.4	CuNiSi	PRESILVER vorversilbert	A = 2.5 B = 3.5 C = 5.2	E = 2.4 G = 2.3 D _{Dr} = 1.0	H = 2.5 K = (2.5) D _{iso} = 1.1 M = 0.2	TYPE B2	HANDCRIMP TOOL 539635-1	
0-1241386-2	C			CuNiSi	TINPLATED vorverzinkt						
0-1241386-1	C			CuNiSi	PRESILVER vorversilbert						
0-1564982-3	C	0.2-0.35	1.1-1.4	CuNiSi	PRESILVER vorversilbert	A = 2.5 B = 3.5 C = 5.2	E = 2.4 G = 2.3 D _{Dr} = 1.0	H = 2.5 K = (2.5) D _{iso} = 1.1 M = 0.2	TYPE B2	INSERT 4-1579016-1	
0-1564982-2	C			CuNiSi	TINPLATED vorverzinkt						
0-1564982-1	C			CuNiSi	PRESILVER vorversilbert						
ORDER NO. Bestell-Nr.	REV.	WIRE RANGE Drahtgroessen- bereich (mm 2)	INSULATION DIA Isolations Ø (mm)	MATERIAL Werkstoff	PLATING Ueberzug	LENGTH Laenge	WIRE CRIMP Drahtcrimp	INSUL. CRIMP Isol.-Crimp	CRIMP DATA AND CRIMP TOOL	EXTRACTION TOOL Ausdruckwerkzeug	CRIMP DATA AND CRIMP TOOL
Strip Bandware											

SEE APPLICATION SPECIFICATION
 siehe Verarbeitungsspezifikation
 114-18387

CONTACTS FOR SINGLE WIRE SEALING SYSTEM:
 FLR- AND FLK- CABLE
 Kontakte fuer Einzel-Dichtung-System:
 FLR- und FLK-Leitung

DIMENSIONS SEE FIGURE "CONTACTS FOR FLR-CABLE"
 Masse siehe Darstellung der Kontakte fuer FLR-Leitung

LOC	DIST	REV	DESCRIPTION	DATE	OWN	APVD
A1	-	-	-	-	-	-
		C13	ECR-15-010777	20JUL2015	SG	RL
		C14	ECR-15-012070	22SEP2015	JBH	BK
		C15	ECR-15-017391	30NOV2015	SG	RL
		C16	Type B2 added, see PCN E-18-010946	19APR2018	FRAN	MERZ

Notes
 Bemerkungen:

- TO BE USED ON Flachstecker / TAB 2.8^{+0.3}_{-0.1} x 0.6^{+0.07}_{-0.03}
 Geeignet fuer Flachstecker / TAB 2.8^{+0.3}_{-0.1} x 0.8 ±0.03
- ALTERNATIVELY LASERWELDED POINT OR LINE SHAPED (DIE CAUSED)
 Laserschweissung wahlweise Punkt- oder Linienformig (Fertigungsbedingt)
- DIE-IDENTIFICATION AND REVISION STATUS
 Kennung fuer Werkzeug und Revisionsstand
- MIN. 0.8µm GOLDPLATE IN CONTACT AREA OVER MIN. 1.3µm NICKELPLATE;
 MIN. 1µm TINPLATE IN CRIMP AREA.
 AS INDEX SEE HOLE AT SPRING
 0,8µm Goldueberzug im Kontaktbereich ueber min. 1,3µm Nickelueberzug;
 min. 1µm Zinnueberzug im Crimpbereich.
 Zur Kennzeichnung siehe Loch an der Ueberfeder
- FOR DOUBLE AND SINGLE CRIMP
 Fuer Doppel- und Einzelcrimp
- SINGLE WIRE SEAL TO BE SELECTED ACCORDING TO INSULATION-DIA
 Auswahl der Einzeldichtung entsprechend dem Isolationsdurchmesser
- MANUFACTURIN-CONDITIONED HOLE, IS STARTING FROM REV. C AT ALL VERSIONS
 Fertigungsbedingtes Loch, befindet sich ab Rev. C an allen Kontakten
- MARKING WITH "Ag" FOR SILVERPLATE IN CONTACT AREA
 Kennzeichnung mit "Ag" bei Silberueberzug im Kontaktbereich
- DIFFERENT FORM OF THE SERRATION POSSIBLE
 Unterschiedliche Ausfuehrung der Rillen moeglich
- PN 1241386 AND 1241392 NOT FOR NEW APPLICATION, REPLACED BY PN 1564982 AND PN1564984.
 PN 1241386 und 1241392 nicht fuer Neuanwendung, Ersatz durch PN 1564982 und 1564984
- DETAILS OF DESIGN ARE LEFT TO MANUFACTURER
 Einzelheiten der Ausfuehrung bleiben dem Hersteller ueberlassen
- "Ag" MARKING ON SILVER PLATED VERSIONS FOR INCREASED LIMIT TEMPERATURE
 "Ag" Markierung auf versilberten Versionen fuer erhoehete Grenztemperatur

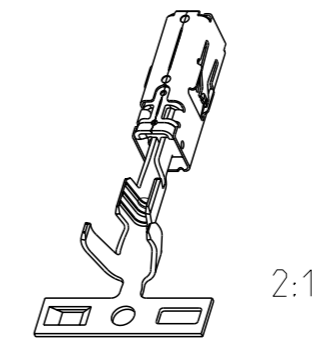

2:1

THIS DRAWING IS A CONTROLLED DOCUMENT.
 DIESER ZEICHNUNGSDRUCK IST EIN KONTROLLIERTES DOKUMENT.
 ANWENDERN SIND DAFUER VERANTWORTLICH, DASS SIE DIE RICHTIGE VERSION NUTZEN.
 THE USER IS RESPONSIBLE FOR USING THE CORRECT VERSION OF THE DRAWING.

DATE Datum	05JUN2006
DESIGNER Entwerfer	P. Liebing
CHECKED Geprueft	-
APPROVED Genehmigt	-
PRODUCT SPEC Produktspez.	108-18717
APPLICATION SPEC Anwendungsspez.	114-18387
MATERIAL Material	see table siehe Tabelle
WEIGHT Gewicht	-
Customer Drawing	/KUNDENZEICHNUNG

SCALE
Maßstab: 10:1

SHEET
Blatt: 1

REV
Rev: C16

Customer Drawing /KUNDENZEICHNUNG SCALE MAßSTAB 10:1 SHEET BLATT 1 OF 1 REV C16