

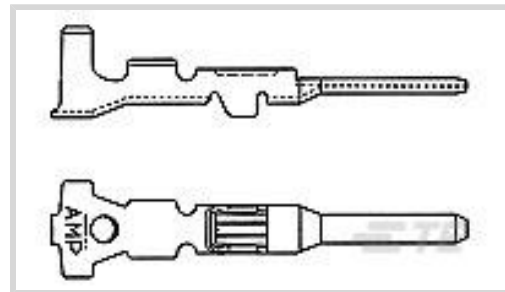

Terminals & Splices > Automotive Terminals > AMP SUPERSEAL 1.5MM, RECEPTACLE AND TAB



Terminal Type: **Tab**

Mating Tab Width: **1.5 mm [.059 in]**

Mating Tab Thickness: **.8 mm [.031 in]**

Terminal Transmits: **0 – 24 A (Low Power)**

Wire Size: **18 – 15 AWG**

[All AMP SUPERSEAL 1.5MM, RECEPTACLE AND TAB \(15\)](#)

Features

Product Type Features

Receptacle Style	180°
Sealable	Yes
Primary Locking Feature	Clean Body

Body Features

Terminal Seal Type	Single Wire Seal (SWS)
--------------------	------------------------

Contact Features

Typical Current Rating	14 A
Crimp Type	F-Crimp
Terminal Type	Tab
Mating Tab Width	1.5 mm [.059 in]
Mating Tab Thickness	.8 mm [.031 in]
Interface Plating	Other
Contact Termination Area Plating Material	Gold (Au)

Termination Features

Termination Method to Wire & Cable	Crimp
Product Terminates To	Wire



Dimensions

Wire Size	.75 – 1.5 mm ²
Wire Size Search	15 AWG, 16 AWG, 17 AWG, 18 AWG
Wire Insulation Diameter	1.7 – 2.4 mm [.071 – .13 in]

Usage Conditions

Insulation Option	Uninsulated
Operating Temperature (Max)	80 °C, 85 °C, 90 °C, 100 °C, 105 °C, 110 °C, 120 °C, 125 °C [176 °F][185 °F][194 °F][212 °F][221 °F][230 °F][248 °F][257 °F]
Operating Temperature Range	-40 – 125 °C [-40 – 257 °F]

Operation/Application

Compatible With Wire Base Material	Copper
------------------------------------	--------

Packaging Features

Packaging Method	Reel
Packaging Quantity	4000

Other

Terminal Transmits	0 – 24 A (Low Power)
--------------------	----------------------

Product Compliance

[For compliance documentation, visit the product page on TE.com>](#)

EU RoHS Directive 2011/65/EU	Compliant
EU ELV Directive 2000/53/EC	Compliant
China RoHS 2 Directive MIIT Order No 32, 2016	No Restricted Materials Above Threshold
EU REACH Regulation (EC) No. 1907/2006	Current ECHA Candidate List: JAN 2022 (223) Candidate List Declared Against: JAN 2022 (223) Does not contain REACH SVHC
Halogen Content	Low Halogen - Br, Cl, F, I < 900 ppm per homogenous material. Also BFR/CFR/PVC Free
Solder Process Capability	Not applicable for solder process capability

Product Compliance Disclaimer

This information is provided based on reasonable inquiry of our suppliers and represents our current actual knowledge based on the information they provided. This information is subject to change. The part numbers that TE has identified as EU RoHS compliant have a maximum concentration of 0.1% by weight in homogenous materials for lead, hexavalent

chromium, mercury, PBB, PBDE, DBP, BBP, DEHP, DIBP, and 0.01% for cadmium, or qualify for an exemption to these limits as defined in the Annexes of Directive 2011/65/EU (RoHS2). Finished electrical and electronic equipment products will be CE marked as required by Directive 2011/65/EU. Components may not be CE marked. Additionally, the part numbers that TE has identified as EU ELV compliant have a maximum concentration of 0.1% by weight in homogenous materials for lead, hexavalent chromium, and mercury, and 0.01% for cadmium, or qualify for an exemption to these limits as defined in the Annexes of Directive 2000/53/EC (ELV). Regarding the REACH Regulation, the information TE provides on SVHC in articles for this part number is based on the latest European Chemicals Agency (ECHA) 'Guidance on requirements for substances in articles' posted at this URL: <https://echa.europa.eu/guidance-documents/guidance-on-reach>

Compatible Parts



TE Part # 785084-1
EXT TOOL SOC-LOC TAB 1.5 CONN



TE Part # 58583-1
PROCrimp HT&D SUPRSEAL 1.5 SER



TE Part # 9-1579007-1
EXTRACTION TOOL

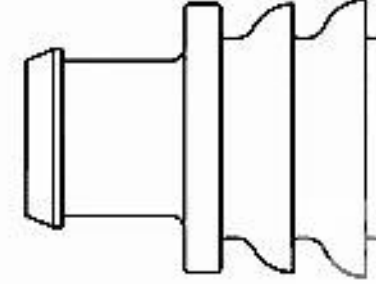

TE Part # 282081-1
RUBBER PLUG

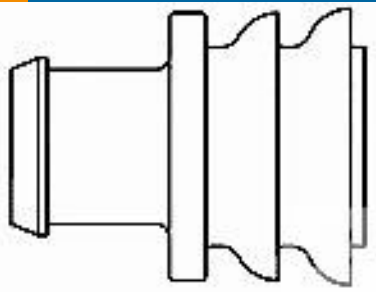

TE Part # 281934-2
SINGLE WIRE SEAL



TE Part # 58583-2
PROCrimp DIE SUPERSEAL 1.5 SER



TE Part # 2305570-1
TERMINAL CUTTER, SIDE FEED



TE Part # CAT-AM71-CH8172
AMP SUPERSEAL 1.5MM, CONNECTOR HOUSING



TE Part # 282403-1
MINI MIC SRS REC CONT



TE Part # 2151204-1
OCEAN-2.0-APPLICATOR-S-090F1450



TE Part # 1745099-1
AMP SUPERSEAL 1,5 SRS. 2 POS. TAB ASSY



TE Part # 2-2151204-1
OCEAN-2.0-APPLICATOR-S-090F1450



TE Part # 2-2151204-2
OCEAN-2.0-APPLICATOR-S-090F1450



TE Part # 2151204-2
OCEAN-2.0-APPLICATOR-S-090F1450



TE Part # 5-2151204-1
OCEAN-2.0-APPLICATOR-S-090F1450



TE Part # 5-2151204-2
OCEAN-2.0-APPLICATOR-S-090F1450



Also in the Series | AMP Superseal 1.5mm Series

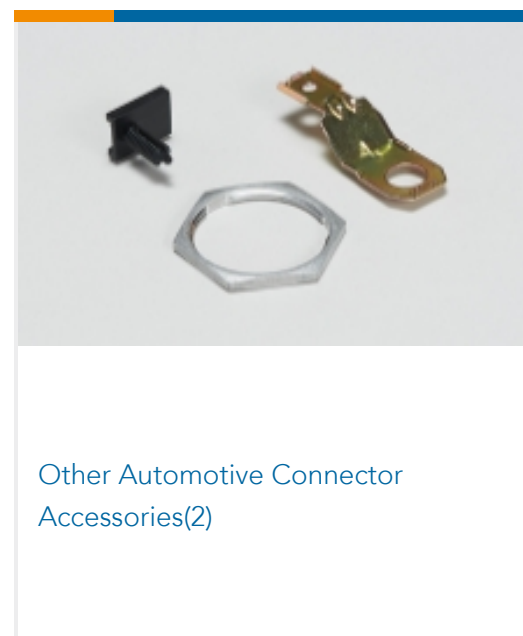
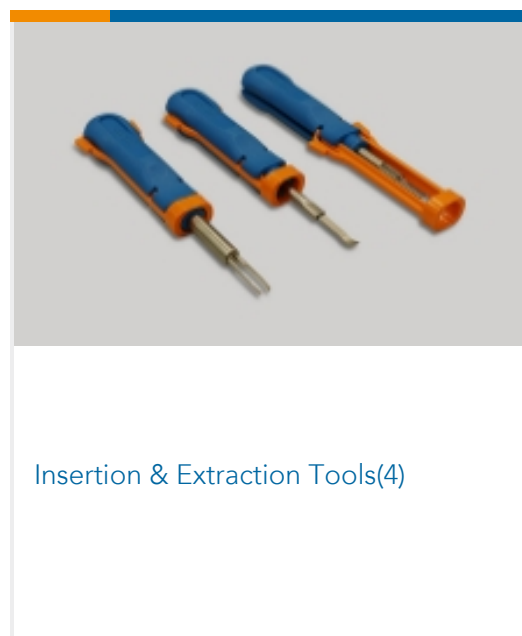
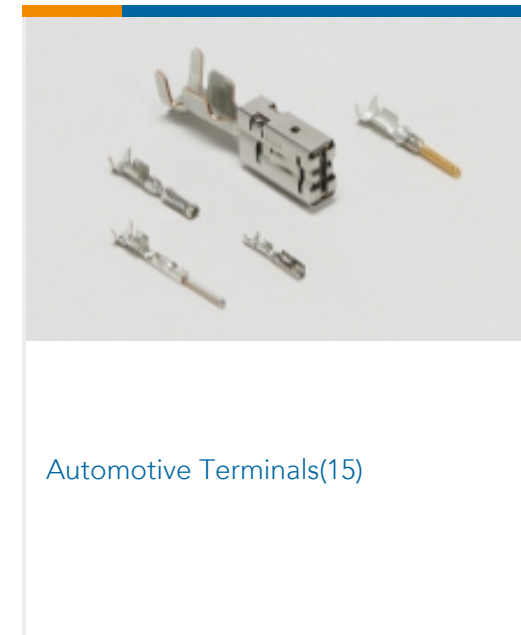
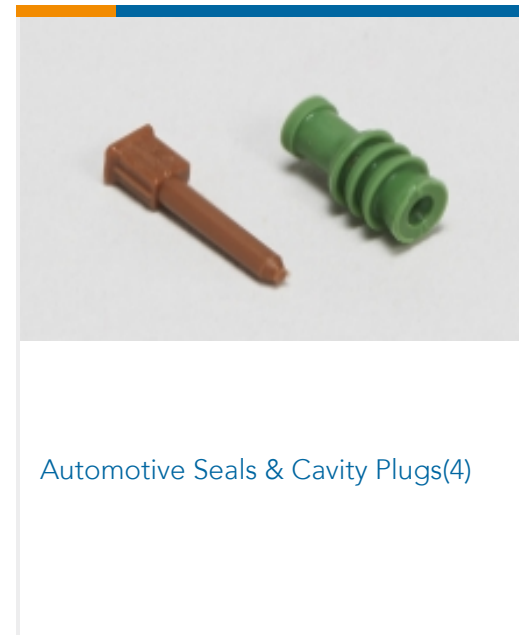
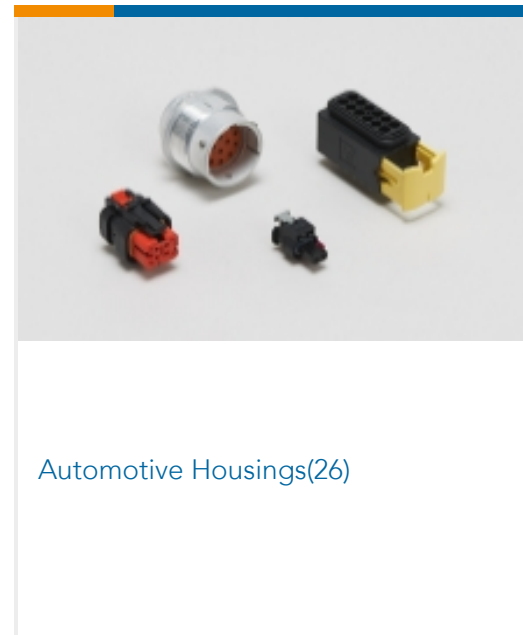
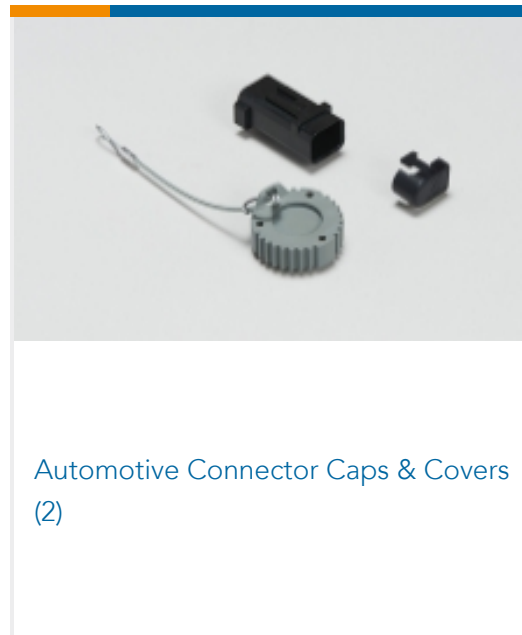

Customers Also Bought

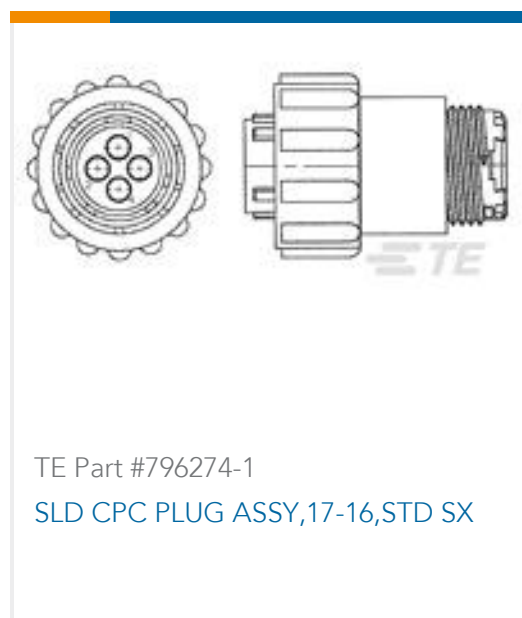



Documents

Product Drawings

MINI MIC TAB CONTACT

English

CAD Files

3D PDF

3D

Customer View Model

[ENG_CVM_CVM_282109-3_E.2d_dxf.zip](#)

English

Customer View Model

[ENG_CVM_CVM_282109-3_E.3d_igs.zip](#)

English

Customer View Model

[ENG_CVM_CVM_282109-3_E.3d_stp.zip](#)

English

By downloading the CAD file I accept and agree to the [Terms and Conditions](#) of use.

Datasheets & Catalog Pages

AMP SUPERSEAL 1.5mm Connector System

English

ICT Terminals and Connectors Catalogue

English

Product Specifications

Application Specification

English