



AMP

TE Internal #: 1612119-1

Automotive Connector Locks & Position Assurance, Black, Wire-to-Board, PBT GF, -30 – 80 °C [-22 – 176 °F]

[View on TE.com >](#)

Connectors > Automotive Connectors > Connector Accessories > Locks & Position Assurance



Primary Product Color: **Black**

Connector System: **Wire-to-Board**

Primary Product Material: **PBT GF**

Operating Temperature Range: **-30 – 80 °C [-22 – 176 °F]**

**Features**

**Product Type Features**

Connector System	Wire-to-Board
------------------	---------------

**Body Features**

Primary Product Color	Black
Primary Product Material	PBT GF

**Usage Conditions**

Operating Temperature Range	-30 – 80 °C[-22 – 176 °F]
-----------------------------	---------------------------

**Industry Standards**

UL Flammability Rating	UL 94HB
------------------------	---------

**Packaging Features**

Packaging Quantity	500
Packaging Method	Bag

**Other**

Serviceable	Yes
-------------	-----

**Product Compliance**

[For compliance documentation, visit the product page on TE.com>](#)

EU RoHS Directive 2011/65/EU	Compliant
EU ELV Directive 2000/53/EC	Compliant
China RoHS 2 Directive MIIT Order No 32, 2016	No Restricted Materials Above Threshold



EU REACH Regulation (EC) No. 1907/2006

Current ECHA Candidate List: JAN 2022 (223)

Candidate List Declared Against: JAN 2022 (223)

Does not contain REACH SVHC

Halogen Content

Low Halogen - Br, Cl, F, I < 900 ppm per homogenous material. Also BFR/CFR/PVC Free

Solder Process Capability

Not applicable for solder process capability

Product Compliance Disclaimer

This information is provided based on reasonable inquiry of our suppliers and represents our current actual knowledge based on the information they provided. This information is subject to change. The part numbers that TE has identified as EU RoHS compliant have a maximum concentration of 0.1% by weight in homogenous materials for lead, hexavalent chromium, mercury, PBB, PBDE, DBP, BBP, DEHP, DIBP, and 0.01% for cadmium, or qualify for an exemption to these limits as defined in the Annexes of Directive 2011/65/EU (RoHS2). Finished electrical and electronic equipment products will be CE marked as required by Directive 2011/65/EU. Components may not be CE marked. Additionally, the part numbers that TE has identified as EU ELV compliant have a maximum concentration of 0.1% by weight in homogenous materials for lead, hexavalent chromium, and mercury, and 0.01% for cadmium, or qualify for an exemption to these limits as defined in the Annexes of Directive 2000/53/EC (ELV). Regarding the REACH Regulation, the information TE provides on SVHC in articles for this part number is based on the latest European Chemicals Agency (ECHA) 'Guidance on requirements for substances in articles' posted at this URL: <https://echa.europa.eu/guidance-documents/guidance-on-reach>

### Compatible Parts

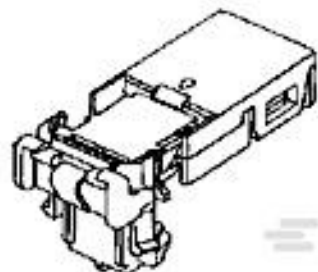

TE Part # 1612120-3  
11DIA SQUIB SLIM MK-2 PLUG HSG

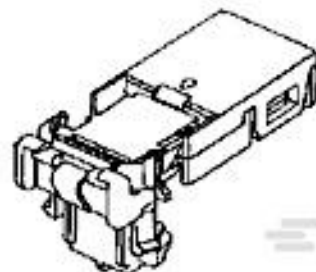

TE Part # 1612120-1  
11DIA SQUIB SLIM MK-2 PLUG HSG

### Customers Also Bought



TE Part #1217281-3  
FF 110 REC 24-20AWG BR



TE Part #170452-2  
PL 250 AUTOMOTIVE REC 22-20 AWG PRE TPBR

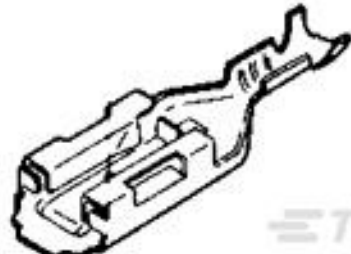

TE Part #170454-2  
PL 250 AM REC 18-14 0.40 X 21 PRE-TPBR

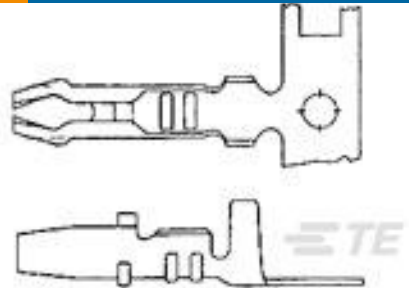

TE Part #170338-1  
AMP-IN 22-18 AWG

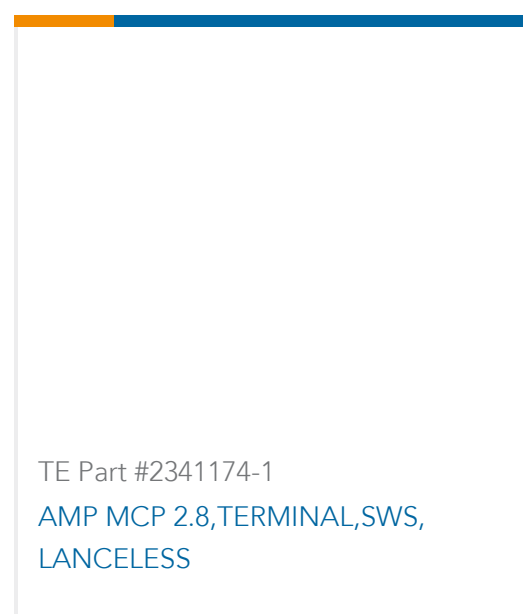
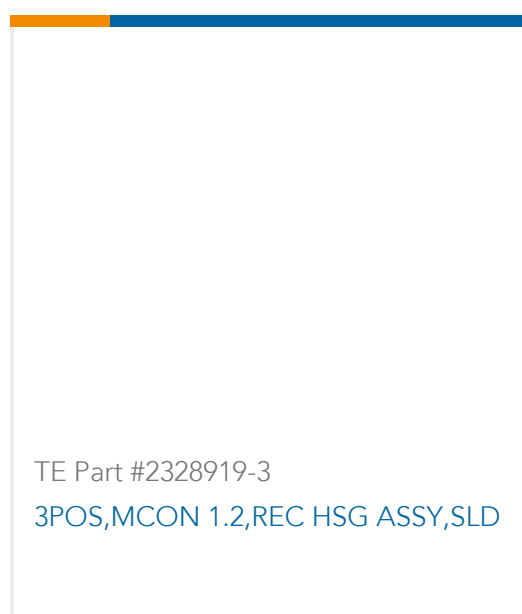
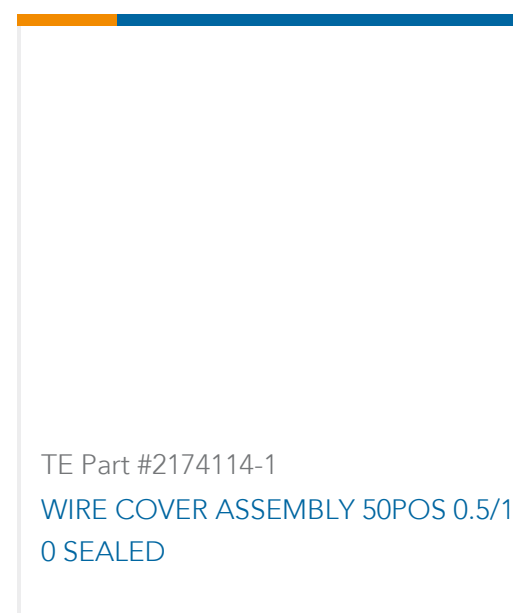
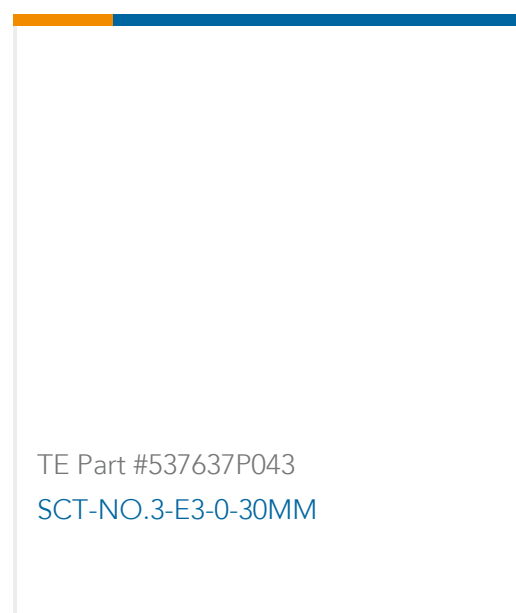
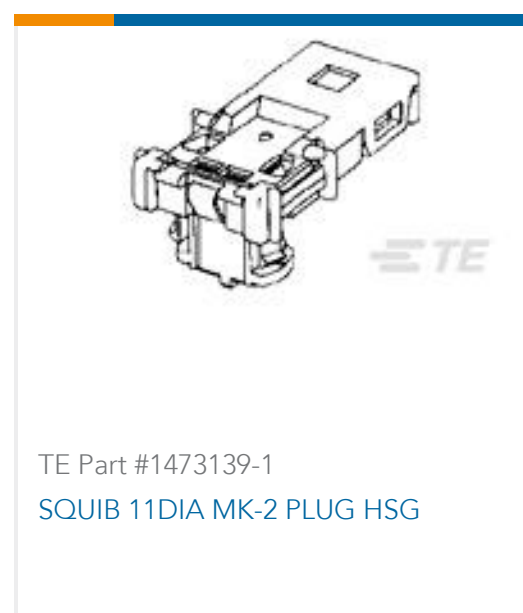

## Documents

### Product Drawings

#### 11DIA SQUIB SLIM MK-2 LOCKING

Japanese

### CAD Files

#### Customer View Model

[ENG\\_CVM\\_CVM\\_1612119-1\\_B.2d\\_dxf.zip](#)

English

#### 3D PDF

3D

#### Customer View Model

[ENG\\_CVM\\_CVM\\_1612119-1\\_B.3d\\_igs.zip](#)

English

#### Customer View Model

[ENG\\_CVM\\_CVM\\_1612119-1\\_B.3d\\_stp.zip](#)

English

By downloading the CAD file I accept and agree to the [Terms and Conditions](#) of use.

### Product Specifications

#### 11DIA SQUIB CONNECTOR SLIM TYPE MK-II

English

#### 11DIA SQUIB CONNECTOR SLIM TYPE MK-II

English

#### 11DIA SQUIB CONNECTOR SLIM TYPE MK-II

English

#### 11DIA SQUIB CONNECTOR SLIM TYPE MK-II

English



[11DIA SQUIB CONNECTOR SLIM TYPE MK-II](#)

English

[11DIA SQUIB CONNECTOR SLIM TYPE MK-II](#)

English

[11DIA SQUIB CONNECTOR SLIM TYPE MK-II](#)

Japanese

[11DIA SQUIB CONNECTOR SLIM TYPE MK-II](#)

Japanese

[11DIA SQUIB CONNECTOR SLIM TYPE MK-II](#)

English

[11DIA SQUIB CONNECTOR SLIM TYPE MK-II](#)

English

---

**Product Environmental Compliance**

[Product Compliance](#)

English

[Product Compliance](#)

English

---

**Instruction Sheets**

[11dia squib connector checker](#)

Japanese

[Instruction Sheet \(non U.S.\)](#)

Japanese