

1473139-1 ✓ ACTIVE

AMP | AMP Auto Squib Products

TE Internal #: 1473139-1

Housing for Female Terminals, Wire-to-Device / Wire-to-Board, 2 Position, .122 in [3.1 mm] Centerline, Yellow, AMP Auto Squib Products

[View on TE.com >](#)



Connectors > Automotive Connectors > Connector Housings

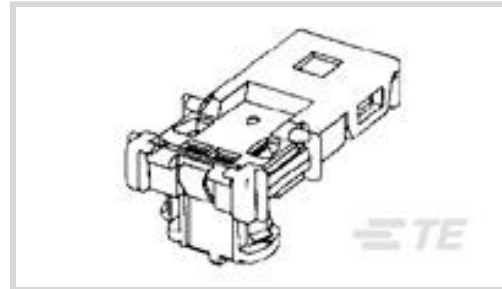

Connector & Housing Type: **Housing for Female Terminals**

Mating Pin Diameter: **1 mm [.039 in]**

Connector System: **Wire-to-Board, Wire-to-Device**

Number of Positions: **2**

Centerline (Pitch): **3.1 mm [.122 in]**

Features

Product Type Features

Connector & Housing Shape	Rectangular
Connector & Housing Type	Housing for Female Terminals
Connector System	Wire-to-Board, Wire-to-Device
Sealable	No
Hybrid Connector	No

Configuration Features

Number of Positions	2
Number of Rows	1

Body Features

Cable Exit Angle	90°
Body Material	PBT
Primary Product Color	Yellow

Contact Features

Contact Size	1mm
Contact Type	Socket
Mating Pin Diameter	1 mm[.039 in]

Mechanical Attachment

Mounting Feature	Without
------------------	---------



Terminal Position Assurance	Yes
Strain Relief	Without
Mating Alignment Type	Polarized
Mating Alignment	With
Connector Mounting Type	Cable Mount (Free-Hanging)

Housing Features

Centerline (Pitch)	3.1 mm[.122 in]
--------------------	-----------------

Dimensions

Product Width	16 mm[.63 in]
Product Length	14 mm[.551 in]
Product Height	29.5 mm[1.161 in]

Usage Conditions

Operating Temperature (Max)	70 °C, 75 °C, 80 °C[158 °F][167 °F][176 °F]
Operating Temperature Range	-30 – 80 °C[-22 – 176 °F]

Industry Standards

UL Flammability Rating	UL 94HB
------------------------	---------

Packaging Features

Packaging Quantity	100
Packaging Method	Bag

Other

Serviceable	Yes
Connector Position Assurance Capable	No

Product Compliance

[For compliance documentation, visit the product page on TE.com>](#)

EU RoHS Directive 2011/65/EU	Compliant
EU ELV Directive 2000/53/EC	Compliant
China RoHS 2 Directive MIIT Order No 32, 2016	No Restricted Materials Above Threshold
EU REACH Regulation (EC) No. 1907/2006	Current ECHA Candidate List: JAN 2022 (223) Candidate List Declared Against: JAN 2022 (223) Does not contain REACH SVHC











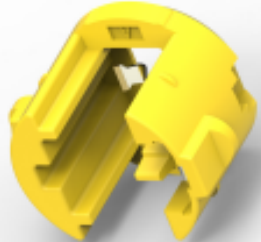

Halogen Content	Low Halogen - Br, Cl, F, I < 900 ppm per homogenous material. Also BFR/CFR/PVC Free
Solder Process Capability	Not applicable for solder process capability

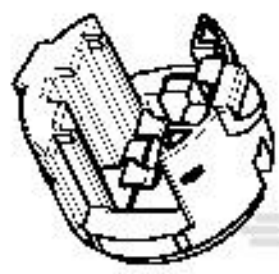
Product Compliance Disclaimer

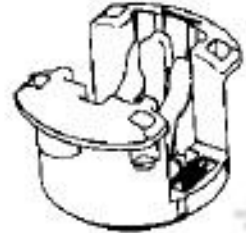
This information is provided based on reasonable inquiry of our suppliers and represents our current actual knowledge based on the information they provided. This information is subject to change. The part numbers that TE has identified as EU RoHS compliant have a maximum concentration of 0.1% by weight in homogenous materials for lead, hexavalent chromium, mercury, PBB, PBDE, DBP, BBP, DEHP, DIBP, and 0.01% for cadmium, or qualify for an exemption to these limits as defined in the Annexes of Directive 2011/65/EU (RoHS2). Finished electrical and electronic equipment products will be CE marked as required by Directive 2011/65/EU. Components may not be CE marked. Additionally, the part numbers that TE has identified as EU ELV compliant have a maximum concentration of 0.1% by weight in homogenous materials for lead, hexavalent chromium, and mercury, and 0.01% for cadmium, or qualify for an exemption to these limits as defined in the Annexes of Directive 2000/53/EC (ELV). Regarding the REACH Regulation, the information TE provides on SVHC in articles for this part number is based on the latest European Chemicals Agency (ECHA) 'Guidance on requirements for substances in articles' posted at this URL: <https://echa.europa.eu/guidance-documents/guidance-on-reach>

Compatible Parts

 <p>TE Part # 1376766-1 SQUIB 11DIA SCR ASSY 9.3MM TYP</p>	 <p>TE Part # 1473140-1 SQUIB 11DIA MK-2 LOCKING BUTTO</p>	 <p>TE Part # 353376-3 SQUIB CONT 1MM PIN DIA SOCKET</p>	 <p>TE Part # 1473369-1 SQUIB 11DIA SCR ASSY 8.8MM TYP</p>
 <p>TE Part # 1612124-3 1DIA SOCKET AU</p>	 <p>TE Part # 1376766-3 SQUIB 11DIA SCR ASSY 9.3MM TYP</p>	 <p>TE Part # 1473369-3 SQUIB 11DIA SCR ASSY 8.8MM TYP</p>	 <p>TE Part # 1473369-4 SQUIB 11DIA SCR ASSY 8.8MM TYP</p>
 <p>TE Part # 1473369-5 SQUIB 11DIA SCR ASSY 8.8MM TYP</p>	 <p>TE Part # 1-1473369-4 SQUIB 11DIA SCR ASSY 8.8MM TYPE</p>	 <p>TE Part # 1473369-7 SQUIB 11DIA SCR ASSY CODE-A GR</p>	 <p>TE Part # 1473369-9 SQUIB 11DIA SCR ASSY 8.8MM TYPE</p>

Also in the Series | **AMP Auto Squib Products**



Automotive Housings(13)



Automotive Terminals(2)



Other Automotive Connector Accessories(8)

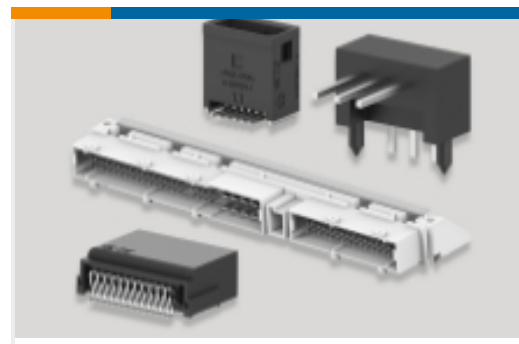

PCB Headers & Receptacles(1)

Customers Also Bought

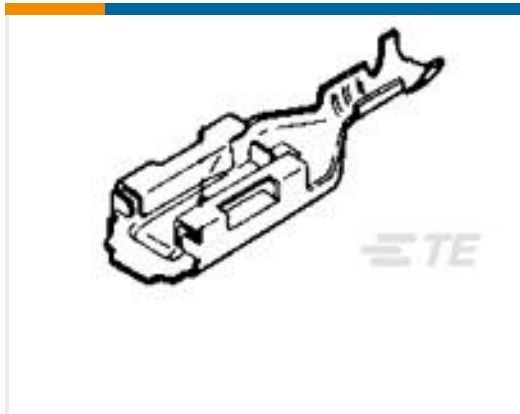

TE Part #170452-2
PL 250 AUTOMOTIVE REC 22-20 AWG
PRE TPBR



TE Part #170454-2
PL 250 AM REC 18-14 0.40 X 21 PRE-
TPBR



TE Part #1717975-1
CAP ASSY,6P,BRACKET REVERSE
TYPE,ATAC CO



TE Part #316837-2
040-3 UNSEALED REC CONT. S AU

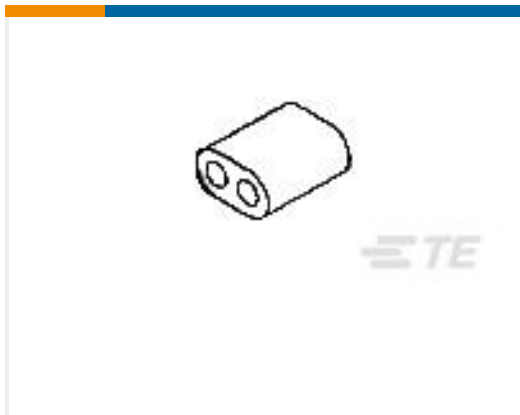

TE Part #353379-2
SQUIB CONN FERRITE

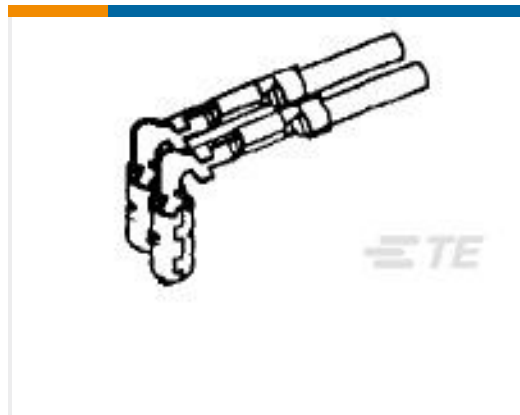

TE Part #353376-3
SQUIB CONT 1MM PIN DIA SOCKET



TE Part #1674311-8
0.64 III RCPT NON SEALED Au



TE Part #2819355-1
E/G ROOM R/B FRAME ASSY



TE Part #CS9984-000
ES2000-NO.3-O5-0-35MM-CS9156



TE Part #CS9985-000
ES2000-NO.2-O6-0-35MM-CS9156

Documents

Product Drawings

[SQUIB 11DIA MK-2 PLUG HSG](#)

Japanese

CAD Files

Customer View Model

[ENG_CVM_1473139-1_B1.3d_igs.zip](#)

English

Customer View Model



[ENG_CVM_1473139-1_B1.3d_stp.zip](#)

English

Customer View Model

[ENG_CVM_1473139-1_B1.2d_dxf.zip](#)

English

3D PDF

English

By downloading the CAD file I accept and agree to the [Terms and Conditions](#) of use.

Product Specifications

AMP Lattice Connector

Japanese

Product Specification

Japanese

SQUIB Connector 11DIA

Japanese

Product Specification

Japanese

SQUIB Connector 11DIA

Japanese

Product Specification

Japanese

11DIA SQUIB CONNECTOR CHECKER

English

11DIA SQUIB CONNECTOR CHECKER

Japanese

Product Environmental Compliance

Product Compliance

English

Product Compliance

English

Instruction Sheets

11 DIA SQUIB CONNECTOR MK-II

English

Instruction Sheet (non U.S.)

English

11dia squib connector checker

Japanese

Instruction Sheet (non U.S.)

Japanese