

SYMBOL DEFINITION		MISSING NUMBERS		DWO STATUS				REVISION HISTORY				AUTH		
DATE	STG	REV	N/P	CHO	ZONE	DATE	STG	REV	N/P	CHO	ZONE	AUTH	DR	APVD
12N099	R	01	-	-	-	12N099	R	01	-	-	-	196852	EOV	GMC
05MY01	R	02	-	-	-	05MY01	R	02	-	-	-	209713	OT	RC
28SE01	R	03	-	-	-	28SE01	R	03	-	-	-	213806	OT	RC
28JA04	U	04	-	-	-	28JA04	U	04	-	-	-	250663	LLJ	LLJ
25FE04	R	05	-	-	-	25FE04	R	05	-	-	-	251796	LLJ	LLJ

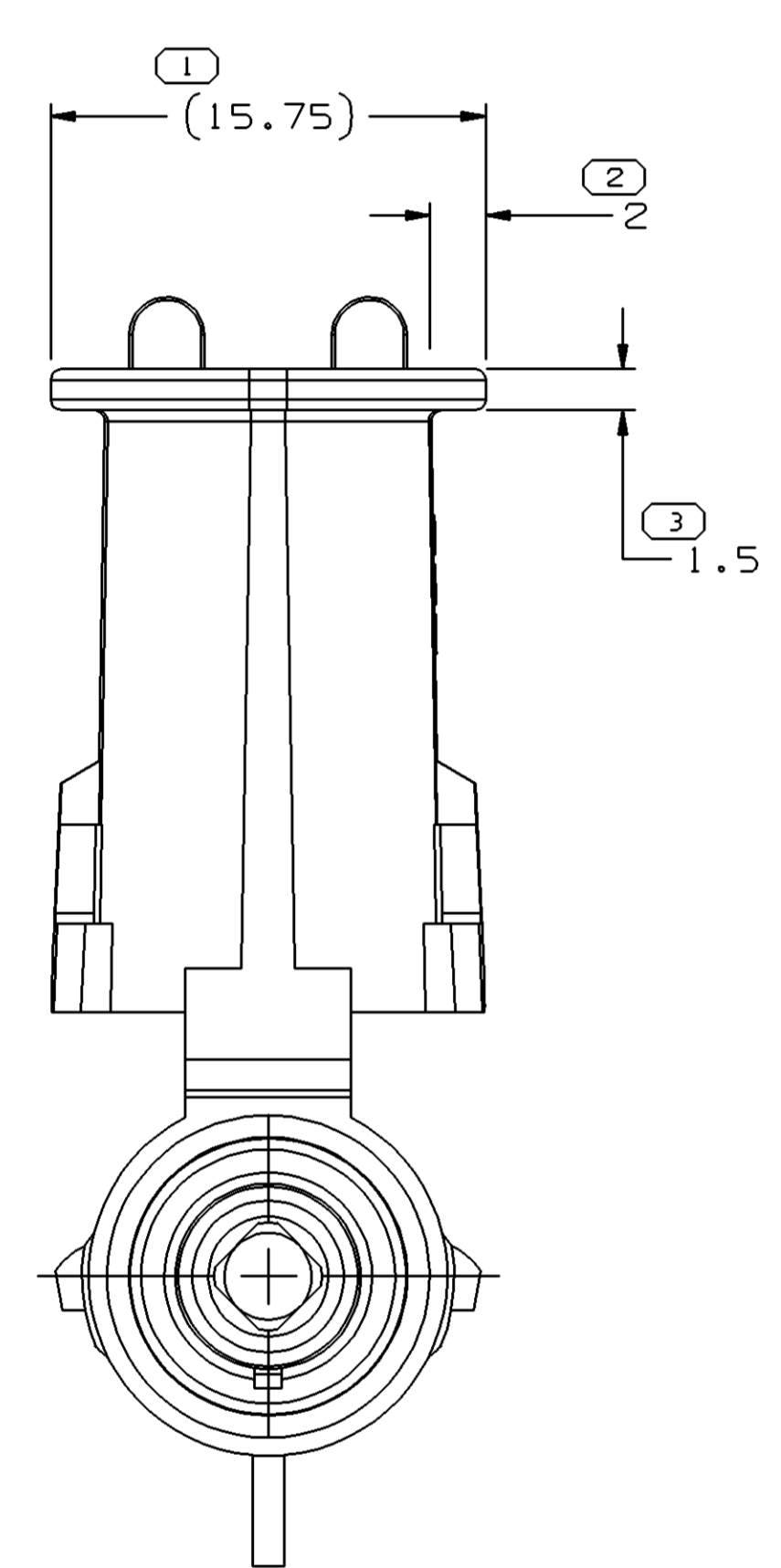

TYPE 102
SAME AS TYPE 101
EXCEPT AS SHOWN

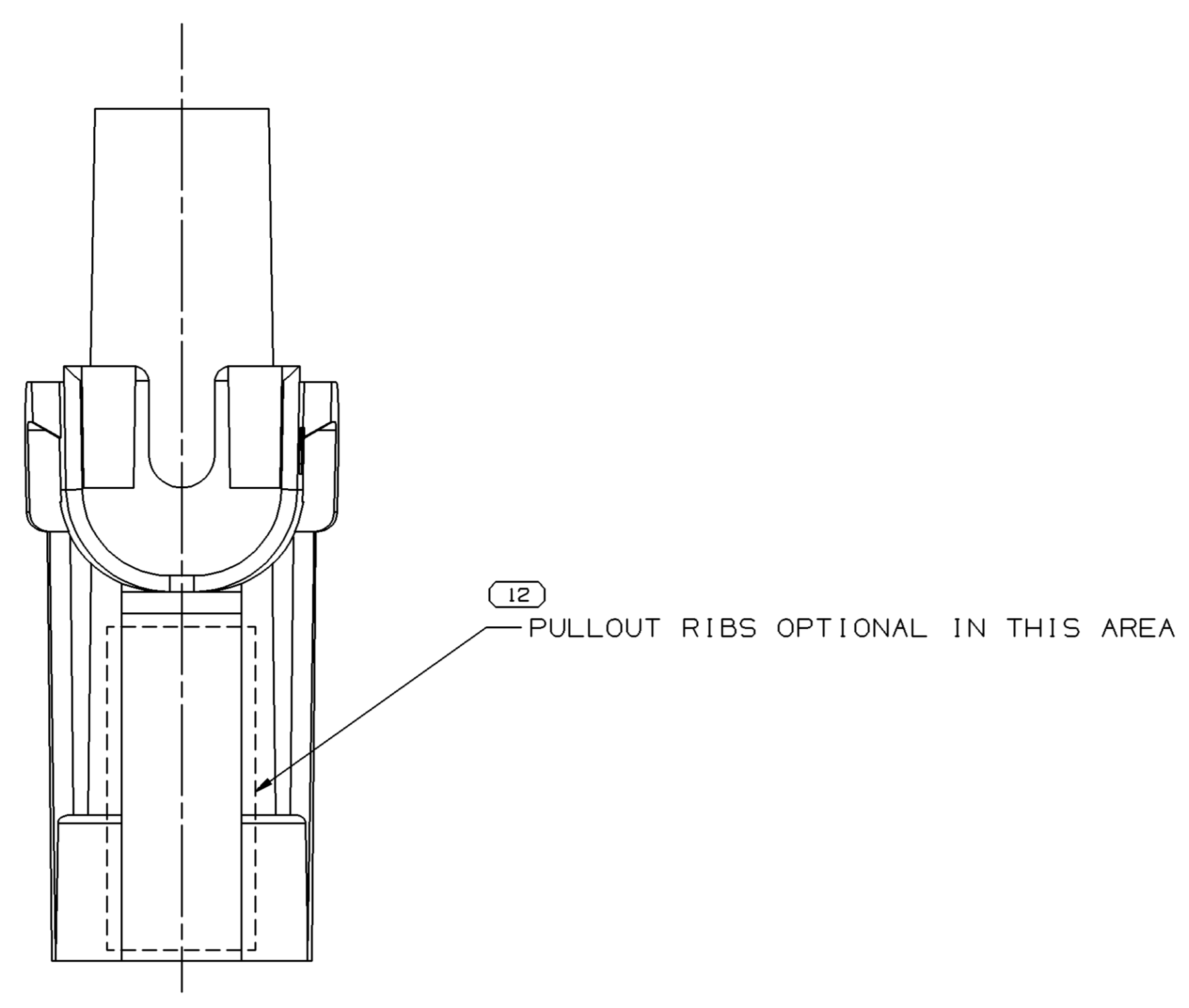
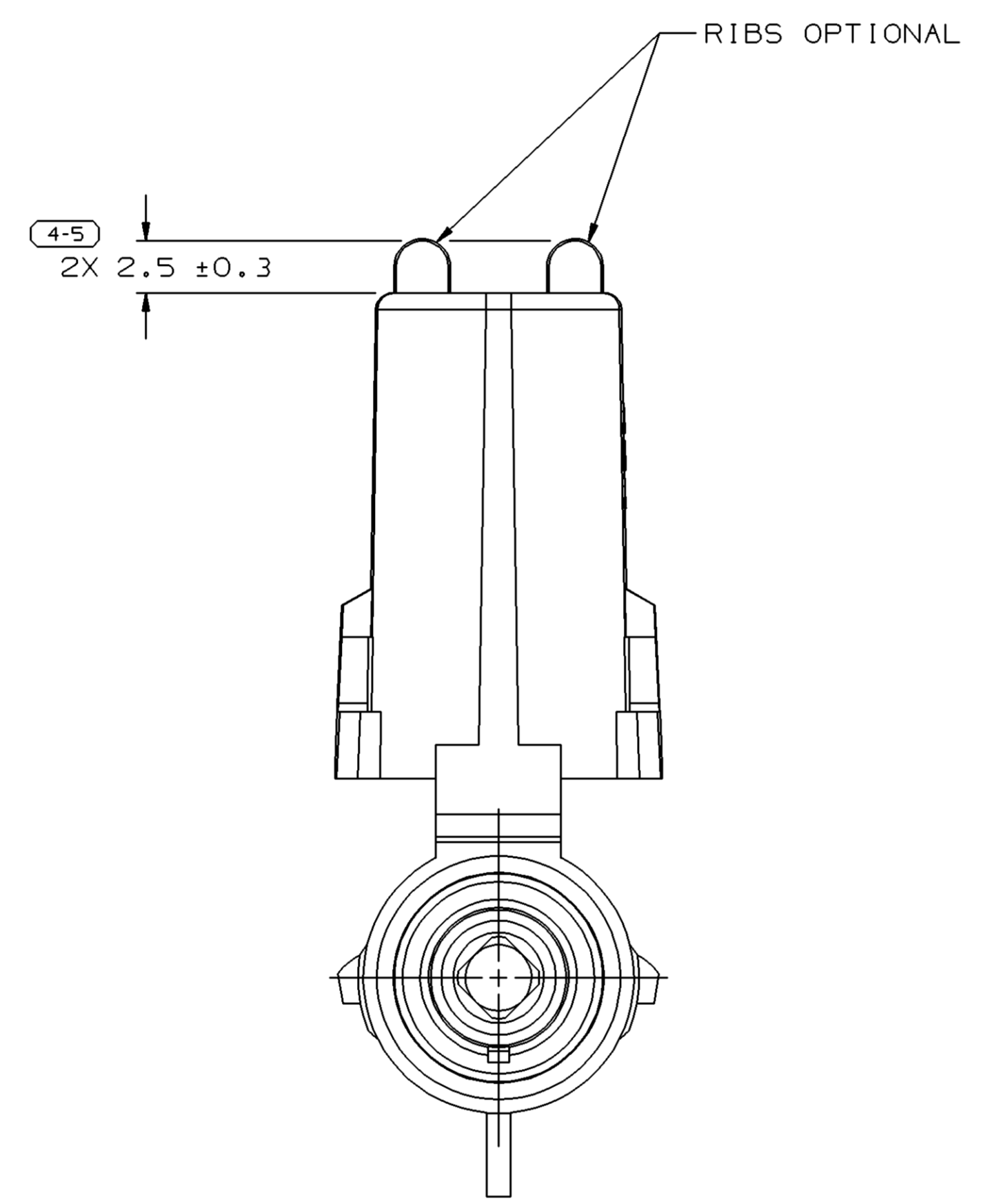

TYPE 101

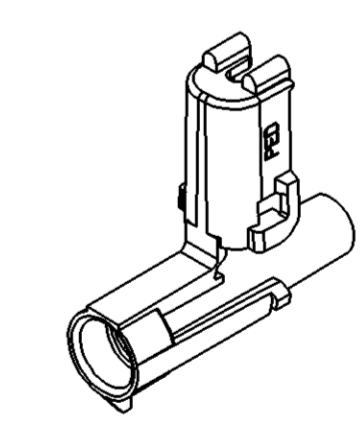
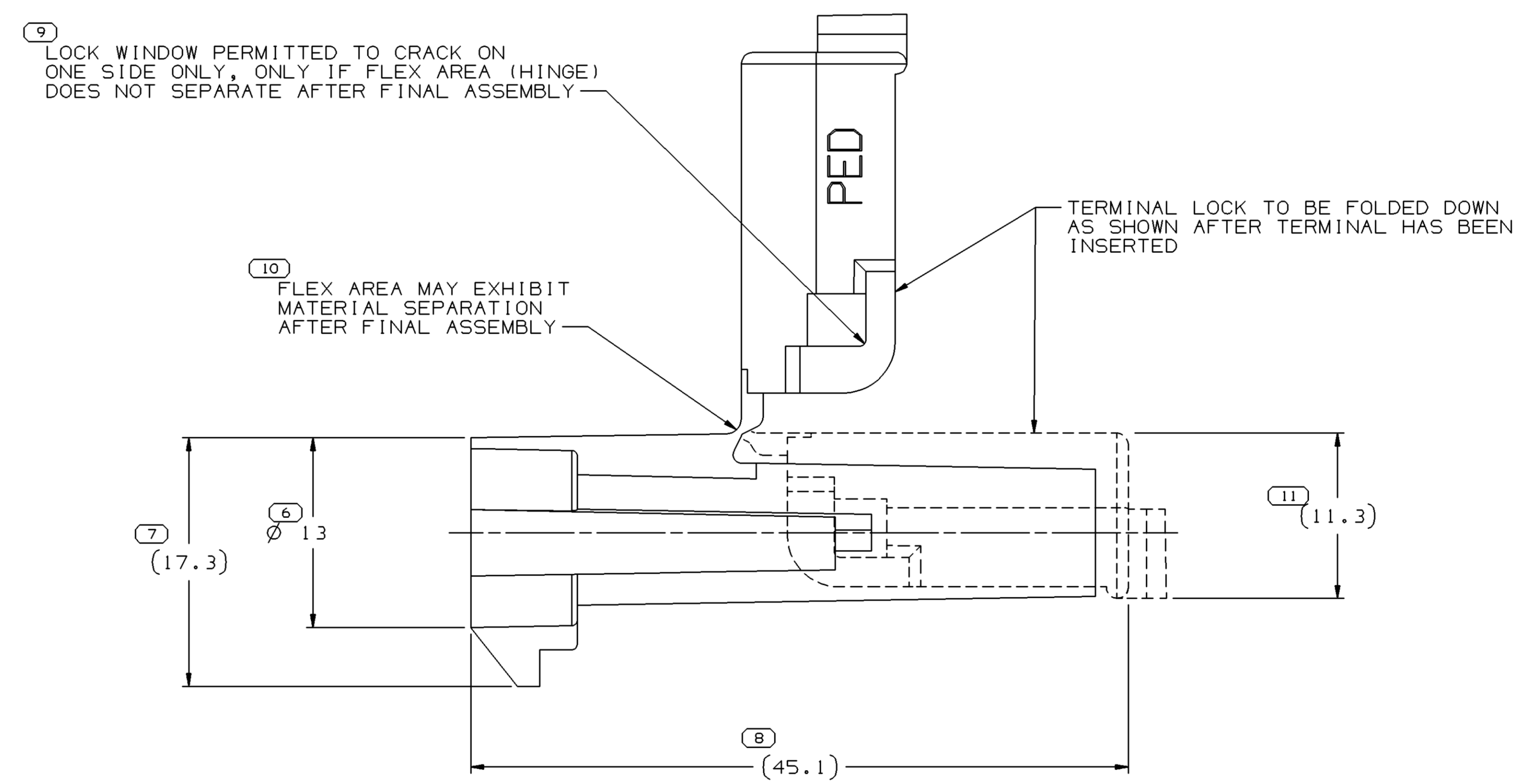

- NOTES:
- UNLESS OTHERWISE SPECIFIED AND/OR INDICATED: DIMENSIONS ARE TO FACE OF VIEW SHOWN AND AUTOMATICALLY ROUNDED BY COMPUTER FOR INSPECTION. (SEE MATH MODEL FOR PRECISE DIMENSION) FOR ALL OTHER DIMENSIONS NOT SHOWN BUT REQUIRED FOR TOOL BUILD, SEE MATH MODEL FOR PRECISE TOOL PATH DATA.
 - MATING COMPONENTS OR EQUIVALENT:
CONNECTOR 12015781
CABLE SEAL 12015323
TERMINAL 12089040
 - SEALING CODE 3.
 - CAUTION: DO NOT ATTEMPT TO COPY THIS DRAWING WHEN DESIGNING A MATING PART TO A WEATHER PACK CONNECTOR. PLEASE REQUEST THE LATEST COPY OF DRAWING NUMBER 12020084 FROM THE PACKARD ELECTRIC DIVISION.
 - (2.3)X(0.1) RAISED DELPHI CORPORATE BRAND TO BE LOCATED ON ANY EXTERIOR SURFACE, PREFERABLY VISIBLE AT FINAL ASSEMBLY. OPTIONAL CONSTRUCTION TO BE "PED" OR NO LOGO.
 - MATERIAL RECYCLING CODE PER ISO 11469. (2.3)X(0.1) RAISED CHARACTERS AS SHOWN TO BE LOCATED ON ANY EXTERIOR SURFACE. OPTIONAL CONSTRUCTION TO BE NO MATERIAL RECYCLING CODE.

PART NO	STG	REV	N/P	STATUS	TYPE	MATERIAL SPECIFICATION AND COLOR	APPLICATION	REF: TERMINAL GENDER	ASSEMBLY PART NUMBER (S)	ASM MATING PART	VOL CM ³
12186965	R	A4	-	-	102	M3592001 PA66 HS IM BLK	IN-LINE	12089040/MALE	-	12015791	3.531
12020803	R	05	AC	-	101	M3592025 PA66 HS IM GRA MD	IN-LINE	12089040/MALE	-	12077615	3.398
12010996	R	E4	-	-	101	M3592001 PA66 HS IM BLK	IN-LINE	12089040/MALE	12047671	12015791	3.398

6 PROCESS SENSITIVE DIMENSION

DIMENSIONS ENCLOSED IN () INDICATE REFERENCE DIMENSIONS AND NO TOLERANCE UNITS ARE ESTABLISHED

FROM	TO	TOLERANCE
0	> 20	> 30
20	> 30	> 70
30	> 70	> 100
70	> 100	> 100

UNLESS OTHERWISE SPECIFIED TOLERANCE UNLESS OTHERWISE SPECIFIED: 1±0.151 ±0.2 | ±0.3 | ±0.4 | ±0.5

ANGULAR TOLERANCE 12°

THIRD ANGLE PROJECTION

DO NOT SCALE

USE MATH DATA

UNSPRINTS

DELPHI

DELPHI PACKARD ELECTRIC SYSTEMS
WARREN, OH

DR	DATE
APVD1 E. MONCISVAIS	30 JUL 96
APVD2 E. BAEZ	05AUG96
APVD3 T. MADDEN	28JA04
APVD4	
APVD5	

SUBSTANCES OF CONCERN AND RECYCLED CONTENT PER DELPHI 10949001

MATERIAL SEC CHART

DRAWING NAME: TAXI CONN W/P SHD

DRAWING NUMBER: 12020814

SIZE A0 SCALE 4:1 FRAME NO 1 OF 1 SHEET NO 1 OF 1 STG REV N/P 05